



The power behind competitiveness

Delta UPS Modulon Family

DPH Gen3 Series, Three-Phase, 380/ 400/ 415 Vac
125-1250 kVA

User Manual

SAVE THIS MANUAL

This manual contains important instructions and warnings that you should follow during the installation, operation, storage and maintenance of this product. Failure to heed these instructions and warnings will void the warranty.

Copyright © 2026 by Delta Electronics Inc. All Rights Reserved. All rights of this User Manual ("Manual"), including but not limited to the contents, information, and figures are solely owned and reserved by Delta Electronics Inc. ("Delta"). The Manual can only be applied to the operation or the use of this product. Any disposition, duplication, dissemination, reproduction, modification, translation, extraction, or usage of this Manual in whole or in part is prohibited without the prior written permission of Delta. Given that Delta will continuously improve and develop the product, changes may be made to the information in this Manual at any time without obligation to notify any person of such revision or changes. Delta will make all possible efforts to secure the accuracy and the integrity of this Manual. Delta disclaims any kinds or forms of warranty, guarantee, or undertaking, either expressly or implicitly, including but not limited to the completeness, faultlessness, accuracy, non-infringement, merchantability or fitness for a particular purpose of the Manual.

Table of Contents

SAVE THIS MANUAL	2
Table of Contents.....	3
Chapter 1 : Important Safety Instructions	8
1.1 Installation Warnings	8
1.2 Connection Warnings	8
1.3 Usage Warnings	10
1.4 Storage Warnings.....	12
1.5 Standard Compliance	12
Chapter 2 : Introduction.....	13
2.1 General Overview	13
2.2 Package Inspection	13
2.3 Functions & Features	15
2.4 Exterior & Dimensions.....	16
2.5 Front View.....	16
2.6 Internal View.....	17
2.7 Tri-color LED Indicator & Buzzer	20
Chapter 3 : Operation Modes.....	22
3.1 On-Line Mode	23
3.2 Battery Mode.....	24
3.3 Bypass Mode.....	25
3.4 Manual Bypass Mode	26
3.5 ECO Mode.....	27
3.6 Green Mode.....	28
3.7 Clean Mode	29
3.8 Frequency Conversion Mode.....	30

3.9	Energy Recycle Mode.....	31
Chapter 4 : Communication Interfaces.....		32
4.1	Communication Interfaces (I): on the Front of the UPS with Its Right Front Door Open.....	32
4.1.1	USB Port & RS-232 Port.....	34
4.1.2	Parallel Communication Cards.....	34
4.1.3	Parallel Ports	35
4.1.4	Synchronized Multiple Bus (SMB) Ports	35
4.1.5	Display Port	36
4.1.6	REPO Dry Contacts.....	36
4.1.7	External Battery Temperature Detection	36
4.1.8	External Breaker Status Dry Contacts	37
4.1.9	Output Dry Contacts.....	38
4.1.10	Input Dry Contacts.....	41
4.1.11	Backfeed Shunt Trip Function	43
4.1.12	Battery Shunt Trip Function	43
4.1.13	Auxiliary Power 48 Vdc	44
4.1.14	Battery Breaker Status Dry Contacts.....	44
4.1.15	External RS-485 & External RS-232 Ports.....	45
4.1.16	Battery Start Button	45
4.1.17	External Synchronization Connector	45
4.1.18	SMART Slots.....	46
4.1.19	Auxiliary Power Cards	47
4.2	Communication Interfaces (II): at the Rear of the Touch Panel	48
4.3	Cable Routing for the Communication Interfaces	49
Chapter 5 : Installation and Wiring.....		51
5.1	Before Installation and Wiring.....	51
5.2	Installation Environment	51
5.3	UPS Installation	53
5.4	Wiring.....	58

5.4.1	Pre-wiring Warnings	58
5.4.2	Single Input and Dual Input Modification.....	62
5.4.3	Single Unit Wiring.....	63
5.4.3.1	Single Input (Single Unit).....	66
5.4.3.2	Dual Input (Single Unit)	70
5.4.4	Parallel Units Wiring.....	71
5.5	External Battery Cabinet Connection Warnings.....	73
5.6	STS Module	81
5.6.1	STS Module Installation.....	81
5.6.2	STS Module Removal.....	85
5.6.3	STS Module's LED Indicator	86
5.7	Power Module (Optional)	87
5.7.1	Power Module Installation.....	88
5.7.2	Power Module Removal.....	92
5.7.3	Power Module's LED Indicator	94
5.8	Installation of Rodent Shields	94
Chapter 6 : UPS Operation		96
6.1	Pre Start-up & Pre Turn-off Warnings.....	96
6.2	Start-up Procedures.....	97
6.2.1	On-Line Mode Start-up Procedures.....	97
6.2.2	Battery Mode Start-up Procedures.....	98
6.2.3	Bypass Mode Start-up Procedures.....	99
6.2.4	Manual Bypass Mode Start-up Procedures	100
6.2.5	ECO Mode Start-up Procedures.....	102
6.2.6	Green Mode Start-up Procedures	104
6.2.7	Clean Mode Start-up Procedures	106
6.2.8	Frequency Conversion Mode Start-up Procedures.....	108
6.2.9	Energy Recycle Mode Start-up Procedures	110
6.3	Turn-off Procedures	112
6.3.1	On-Line Mode Turn-off Procedures.....	112

6.3.2	Battery Mode Turn-off Procedures.....	113
6.3.3	Bypass Mode Turn-off Procedures.....	113
6.3.4	Manual Bypass Mode Turn-off Procedures.....	114
6.3.5	ECO Mode Turn-off Procedures.....	114
6.3.6	Green Mode Turn-off Procedures.....	114
6.3.7	Clean Mode Turn-off Procedures.....	115
6.3.8	Frequency Conversion Mode Turn-off Procedures.....	115
6.3.9	Energy Recycle Mode Turn-off Procedure.....	116
6.4	Start-up & Turn off Procedures for Parallel Units.....	117
Chapter 7 : LCD Display & Settings.....		119
7.1	LCD Display Hierarchy.....	119
7.2	How to Turn on the LCD.....	123
7.3	Introduction of Touch Panel and Function Keys.....	124
7.4	Password Entry.....	130
7.5	Check Kilowatt-Hour.....	130
7.6	UPS Settings.....	132
7.6.1	Bypass Setting.....	132
7.6.2	Mode Setting.....	133
7.6.3	Input & Output Setting.....	134
7.6.4	Battery & Charging Setting.....	136
7.6.5	Parallel Setting.....	141
7.6.6	Dry Contact Setting.....	141
7.6.7	General Setting.....	143
7.6.8	Net Setting.....	144
7.6.9	Net Notification.....	148
7.6.10	Control.....	149
7.7	System Maintenance.....	150
7.7.1	Warning.....	150
7.7.2	Historical Event.....	150
7.7.3	Statistics.....	151

7.7.4	Test.....	151
7.7.5	Battery Discharge Curve.....	151
7.7.6	Clear.....	151
7.7.7	Advanced Diagnosis.....	152
7.7.8	Version & S/N	153
Chapter 8 : Optional Accessories		154
8.1	EMS Function on the LCD Screen	155
8.2	MFC Function on the LCD Screen	159
Chapter 9 : Maintenance		161
Appendix 1 : Technical Specifications		164
Appendix 2 : Warranty		168

Chapter 1 : Important Safety Instructions

1.1 Installation Warnings

- This is a three-phase four-wire on-line uninterruptible power supply (hereafter referred to as 'UPS'). It can be used for commercial and industrial applications.
- Install the UPS in a well-ventilated indoor area, away from excess moisture, heat, dust, flammable gas or explosives. To avoid fire accidents and electric shock, the indoor area must be free of conductive contaminants. For the temperature and humidity specifications, please refer to ***Appendix 1: Technical Specifications***.
- Leave adequate space around all sides of the UPS for proper ventilation and maintenance. Please refer to ***5.2 Installation Environment***.
- Only authorized Delta engineers or service personnel can perform installation and maintenance. If you want to install the UPS by yourself, please install it under the supervision of authorized Delta engineers or service personnel.
- Do not drill holes on the UPS. Drilling operations must be approved by the Delta's FSR department in advance. Failure to heed these instructions and warnings will void the warranty.
- Do not step, stand, or sit on the UPS; otherwise, personal injury and/ or equipment damage may occur.
- Follow the IEC 60364-4-42 standard to install the UPS.

1.2 Connection Warnings

- Before applying electrical power to the UPS, make sure that the UPS is grounded to avoid a possible risk of current leakage.
- You can parallel a maximum of eight UPS units.
- The UPS must be connected with an external battery cabinet (handled and configured by Delta service personnel). Please refer to ***5.5 External Battery Cabinet Connection Warnings*** for relevant information. It is necessary to connect the protective devices with the UPS when the UPS is connected to power sources and critical loads.
- The UPS must be connected with an external maintenance bypass cabinet (user-supplied, handled and configured by Delta service personnel). For information regarding the external maintenance bypass cabinet, please refer to the table below.

<p>External Maintenance Bypass Cabinet (user-supplied, handled and configured by Delta service personnel)</p>	<p>For configurations of the external maintenance bypass cabinet, please refer to the following.</p> <ol style="list-style-type: none"> For single input, you must install an input switch, a manual bypass switch and an output switch. For dual input, you must install an input switch, a bypass switch, a manual bypass switch and an output switch. Each switch mentioned above must be a 3-pole (L1/ L2/ L3) device and meets the specifications defined in <i>Table 5-2</i> and <i>Table 5-4</i>. Each switch mentioned above should be configured with an auxiliary switch. The auxiliary switch must have a normally open (NO) contact and a normally closed (NC) contact connected to the UPS system cabinet's dry contacts to detect each switch's ON/ OFF status. Please refer to 4.1.8 External Breaker Status Dry Contacts. Install the external maintenance bypass cabinet next to the UPS or align it with the UPS for convenient operation.
--	--

- It is necessary to connect the protective devices with the UPS when the UPS is connected to power sources and critical loads.
- The protective devices connected to the UPS must be installed near the UPS and easily accessible for operation.
- Protective Devices:
 - For single input, you must install (1) a protective device between the main AC source and the UPS and (2) a protective device between the connected critical loads and the UPS.
 - For dual input, you must install (1) a protective device between the main AC source and the UPS, (2) a protective device between the bypass source and the UPS and (3) a protective device between the connected critical loads and the UPS.
 - For grounding information, please refer to *Figure 5-15* and *Figure 5-18*.
 - The recommended electrical rating of the input, output and backfeed protection devices are as follows. Application of the protective devices shall be in accordance with local installation codes.

750kVA/ 750kW	875kVA/ 875kW	1000VA/ 1000kW	1125kVA/ 1125kW	1250kVA/ 1250kW
500V/2000A	500V/2500A	500V/2500A	500V/3200A	500V/3200A

5. Each protective device should have the functions of overcurrent protection, short circuit protection, insulating protection and shunt trip feature.
6. When selecting the protective devices, please take each power cable's current capacity and the system's overload capacity (please refer to ***Appendix 1: Technical Specifications***) into consideration. Besides, the short-circuit capacity of the upstream protective devices must be equal to or larger than the capacity of the UPS's input protective devices.
7. If the UPS is supplied by a power source whose neutral is grounded, each protective device must be a 3-pole type. If the UPS is supplied by a power source whose neutral is not grounded, each protective device must be a 4-pole type.

1.3 Usage Warnings

- Only qualified service personnel can upgrade the UPS's firmware.
- Please note that any power module slot without installation of power module needs to be installed the power module slot cover.
- Only when (1) the UPS runs in manual bypass mode, (2) the capacitors are completely discharged and (3) the battery power is completely cut off can qualified service personnel perform maintenance. Otherwise, there will be a risk of injury or death.
- Before working on the UPS system, check for hazardous voltage between all terminals including the protective earth (PE).
- Before installation, wiring and working on the UPS's internal circuits, please completely cut off all power supplying to the UPS, including the input power and battery power.
- The UPS is specifically designed for information technology equipment and used to power computers, servers, and associated peripheral devices. If you want to connect any capacitive loads or non-linear loads (that have serious surge current) to the UPS, it needs to be de-rated according to on-site applications. For such special applications, please contact Delta service personnel for the accurate UPS sizing. The UPS is not suitable for connecting with any asymmetrical loads. For the load suitability, please contact Delta customer service before purchasing.
- The external slits and openings in the UPS are provided for ventilation. To ensure reliable operation of the UPS and to protect the UPS from overheating, these slits and openings must not be blocked or covered. Do not insert any object into the slits and openings that may hinder ventilation.
- Before applying electrical power to the UPS, you must allow the UPS to adjust to room temperature 20 ~ 25°C (68 ~ 77°F) for at least one hour and ensure that there is no moisture condensing inside the unit.

- Do not put beverages on the UPS, external battery cabinet(s) or any other accessory associated with the UPS.
- Do not open or remove the covers or panels of the UPS to avoid high-voltage electric shock. Only authorized Delta engineers or service personnel can do so for installation or maintenance. If you want to open or remove the covers or panels, do it only under the supervision of authorized Delta engineers or service personnel.
- It is not recommended that you connect the UPS to any regenerative loads. For the load suitability, please contact Delta customer service before purchasing.
- The risk of dangerous high voltage is possible when batteries are still connected to the UPS even though the UPS is disconnected from the power sources. Before maintenance of the UPS, turn off each external battery cabinet's circuit breaker to completely cut off the battery power from the UPS.
- Do not dispose of the battery or batteries in a fire. The batteries may explode.
- Do not open or damage the battery or batteries. The released electrolyte is harmful to the skin and eyes and may be toxic.
- The UPS is electronic equipment that runs 24 hours continuously. To ensure its normal lifetime, regular maintenance of the UPS and batteries is of vital importance and necessary.
- Some components like batteries, power capacitors, and fans will become worn-out due to long-term usage, and this will increase the risk of UPS failure. To replace and maintain the components, please contact Delta service personnel.
- A battery can present a risk of electrical shock and high short-circuit current. Contact with any part of a grounded battery can result in electrical shock. Please observe the following precautions when working on batteries:
 1. Remove watches, rings, or other metal objects.
 2. Use tools with insulated handles.
 3. Wear rubber gloves and boots.
 4. Do not lay tools or metal parts on top of the batteries.
 5. Disconnect charging source and loads prior to installing or maintaining the batteries.

6. Remove battery grounds before installation and maintenance to reduce likelihood of shock. Remove the connection from ground if any part of the battery is determined to be grounded. Please note that the battery grounds mean any battery pole (+/ -) connecting to the ground.
- You must contact Delta customer service if any of the following events occurs:
 1. Any liquid is poured or spilled on the UPS.
 2. The UPS is deformed.
 3. Any conductive powders or metals enter into the UPS.
 4. The UPS does not run normally after you carefully followed the instructions in this *User Manual*.

1.4 Storage Warnings

- Use the original packing materials to pack the UPS to prevent any possible damage from rodents.
- If the UPS needs to be stored prior to installation, it should be placed in a dry indoor area. The allowable storage temperature is below 70°C (158°F) and relative humidity is below 95%.

1.5 Standard Compliance

- EN 62040-1
- EN 62040-2 Category C3
- EN 61000-4-2 Level 4
- EN 61000-4-3 Level 3
- EN 61000-4-4 Level 4
- EN 61000-4-5
- EN 61000-4-6

Chapter 2 : Introduction

2.1 General Overview

The DPH Gen3 series UPS, a three-phase four-wire online modular uninterruptible power supply (hereafter referred to as 'UPS'), is a dedicated design for data centers, factory facilities and large scale power systems. The unit not only adopts advanced SiC MOSFET technology to provide high quality, low noise, pure and uninterruptible output power to the connected loads but also applies the latest design of DSP digital control technology and highest quality components.

2.2 Package Inspection

During UPS transportation, some unpredictable situations might occur. It is recommended that you inspect the UPS exterior packaging. If you notice any damage, please immediately contact the dealer from whom you purchased the unit.

Please check if any items are missing according to the following package list. If the UPS needs to be be returned, carefully repack the UPS and all of the accessories using the original packing materials that came with the unit.

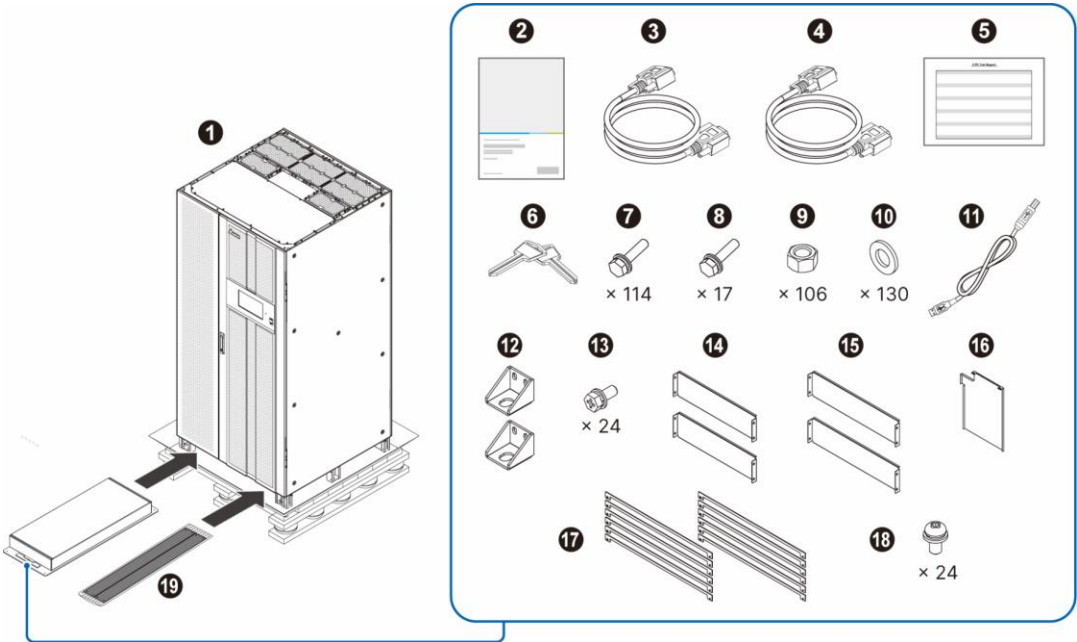

No.	Item	Q'ty
①	UPS	1 PC
②	User Manual	1 PC
③	RS-232 Cable	1 PC
④	Parallel Cable (length: 5 m (196.85"))	1 PC
⑤	Test Report	1 PC
⑥	Key	2 PCS
⑦	M12 Screw_ 45L	114 PCS
⑧	M12 Screw_ 60L	17 PCS
⑨	M12 Nut	106 PCS
⑩	M12 Washer	130 PCS
⑪	USB Cable	1 PC
⑫	Seismic Kit (including two wall brackets)	1 Set
⑬	M5 Screw	24 PCS
⑭	Rodent Shield (type A)	2 PCS
⑮	Rodent Shield (type B)	2 PCS
⑯	Insulating Plate	1 PC
⑰	Metal Windshield	12 PCS
⑱	M4 Screw	24 PCS
⑲	Rodent Shield (type C)	1 PC
	Rodent Shield (type D)	1 PC

2.3 Functions & Features

- Automatic input frequency detection enables operation at 50Hz or 60Hz.
- Automatic restart:
 1. After a low battery shutdown, the UPS inverter will restart in On-Line mode automatically right after the AC input resumes.
 2. The UPS returns automatically to On-Line mode from Bypass mode after an overload condition is cleared.
- Both auxiliary power and control circuit adopt redundancy design, which doubly enhances UPS reliability.
- Generator compatible.
- Surge protection and EMI filter functions.
- Support of external switch/ breaker status detection.
- Wide AC input voltage range (187/ 323 Vac ~ 276/ 477 Vac (100% load); (144/ 249 Vac ~ 187/ 323 Vac (70% ~ 100% load)) reduces frequent transfer from On-Line mode to Battery mode to save battery consumption and prolong battery life.
- AC start-up function even when the UPS is not connected to the batteries.



WARNING:

Please note that when the UPS is not connected to the batteries, it will not protect your equipment if the utility power is lost.

- Provision of setting options such as battery test (schedulable) and battery replacement alarm.
- Battery temperature monitoring and compensation.
- Smart battery charger design allows auto-charging or manual charging to shorten charging time.
- Built-in memory stores a maximum of 10,000 event logs.
- Fan speed auto adjustment prolongs fan life and reduces noise when the critical loads decrease. Moreover, fan failure detection circuit is established.
- State-of-the-art microprocessor technology performs self-detection and monitors fan speed in real time, which provides complete and detailed operating status of the UPS.

2.4 Exterior & Dimensions

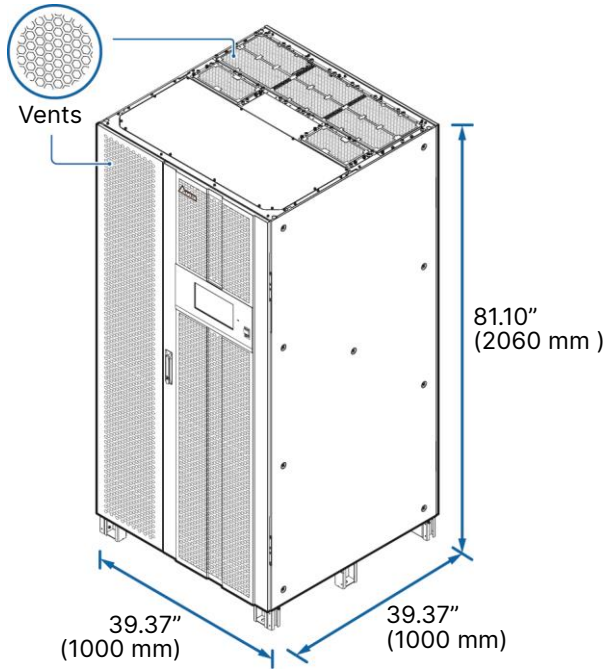

Figure 2-1: Exterior & Dimensions

2.5 Front View

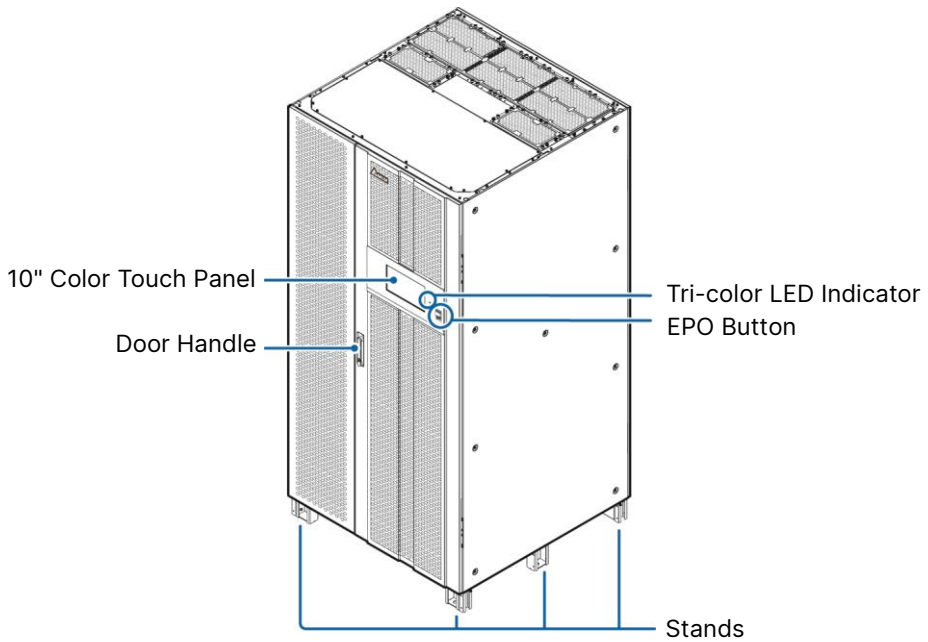

Figure 2-2: Front View

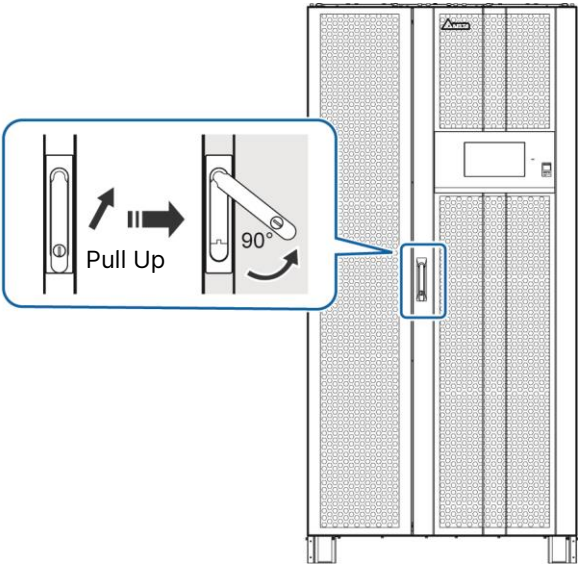

Figure 2-3: How to Open the Front Doors

2.6 Internal View



WARNING:

Only authorized Delta engineers or service personnel can perform installation, wiring, panel & cover removal, maintenance and operation. If you want to execute any action mentioned above by yourself, the action must be under the supervision of authorized Delta engineers or service personnel.

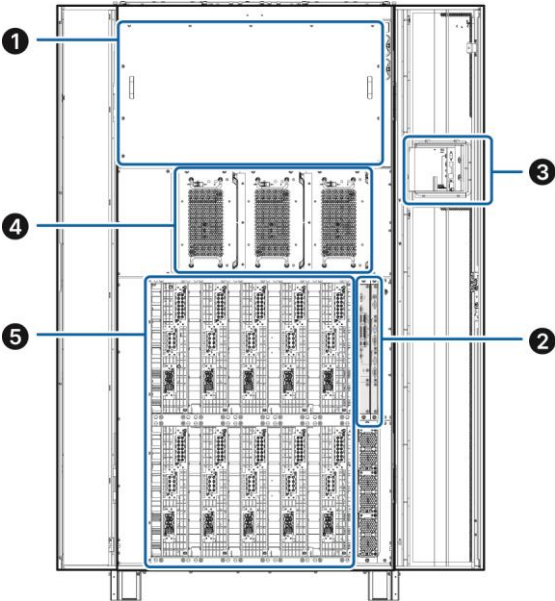
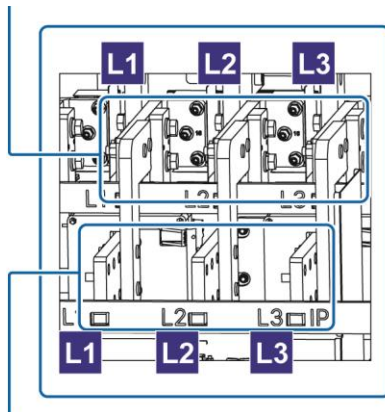

Figure 2-4: Internal View with the Front Doors Open

①	Wiring Terminal Cover
②	Communication Interfaces (I)
③	Communication Interfaces (II)
④	STS Module x 3 PCS
⑤	Power Module Slot x 10 PCS (please install an appropriate number of power modules according to UPS capacity)

To access the wiring terminals, please open the front doors and remove the wiring terminal cover.

Bypass Input Terminals (L1/ L2/ L3)



AC Input Terminals (L1/ L2/ L3)

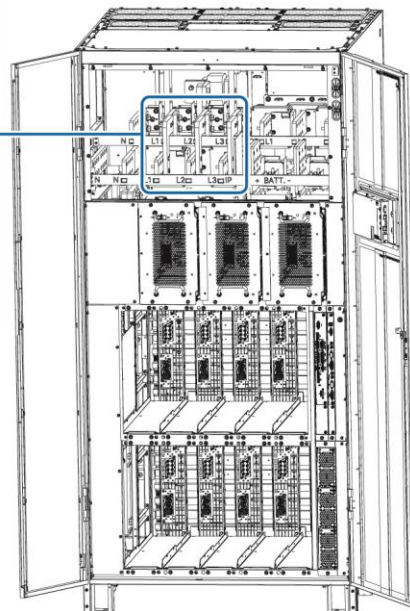

Figure 2-5: AC Input Terminals (L1/ L2/ L3) & Bypass Input Terminals (L1/ L2/ L3)

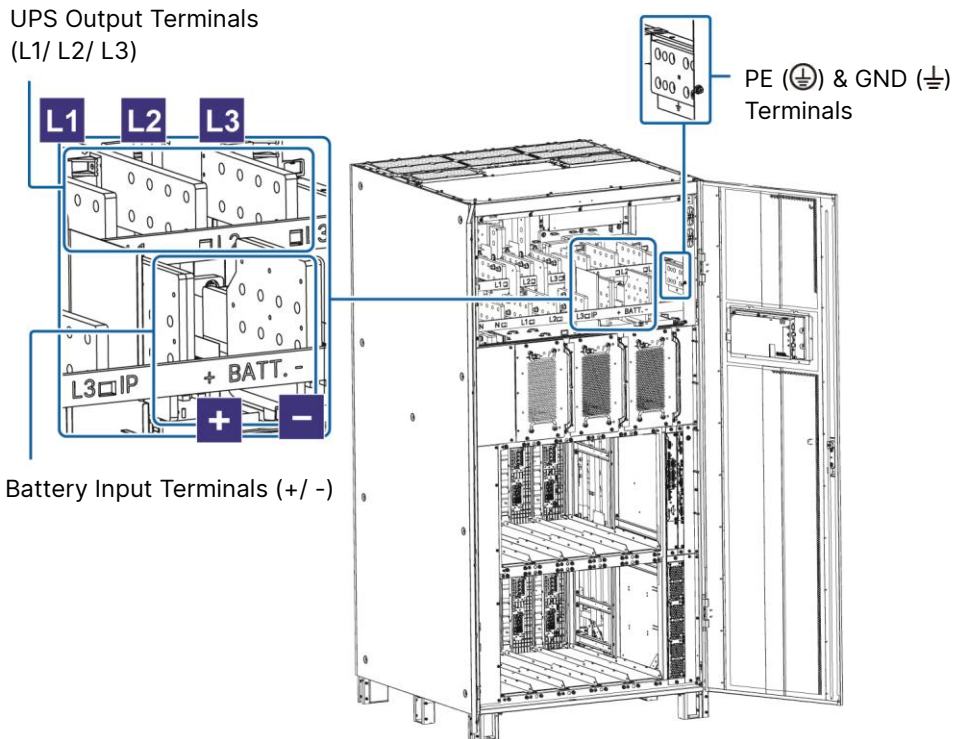

Figure 2-6: UPS Output Terminals (L1/ L2/ L3), Battery Input Terminals (+/-), PE (⊕) & GND (⊖) Terminals

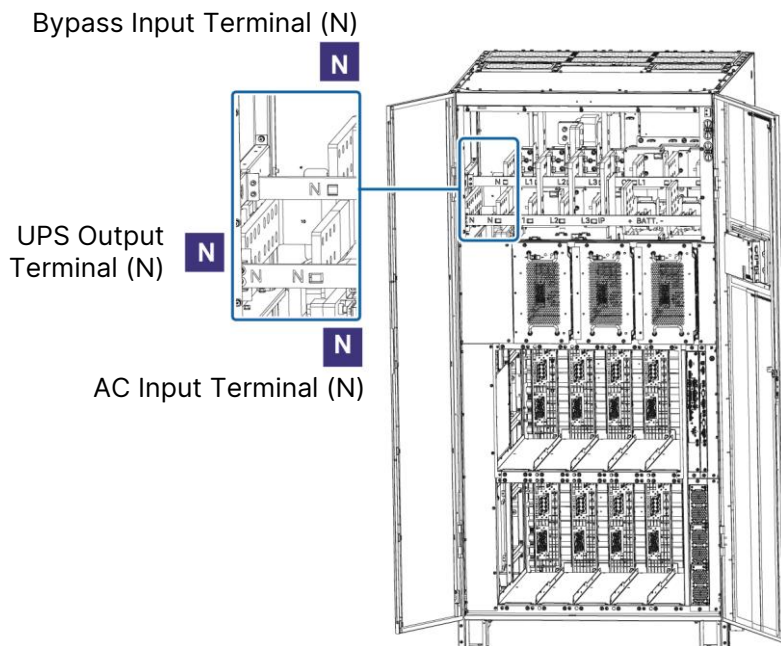

Figure 2-7: AC Input Terminal (N), Bypass Input Terminal (N) & UPS Output Terminal (N)

2.7 Tri-color LED Indicator & Buzzer

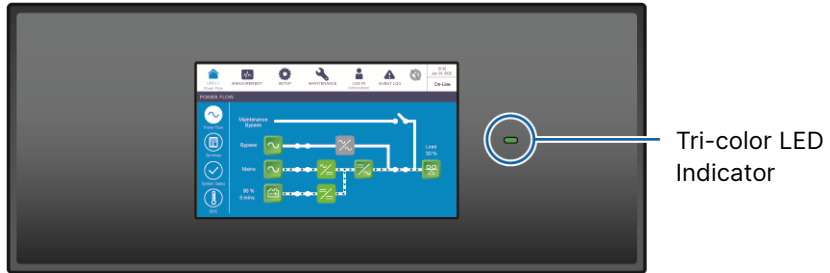

Figure 2-8: Tri-color LED Indicator Location



NOTE:

For information about the 10" color touch panel, please refer to *7. LCD Display & Settings*.

The buzzer is located behind the right front door. Please refer to the figure below.

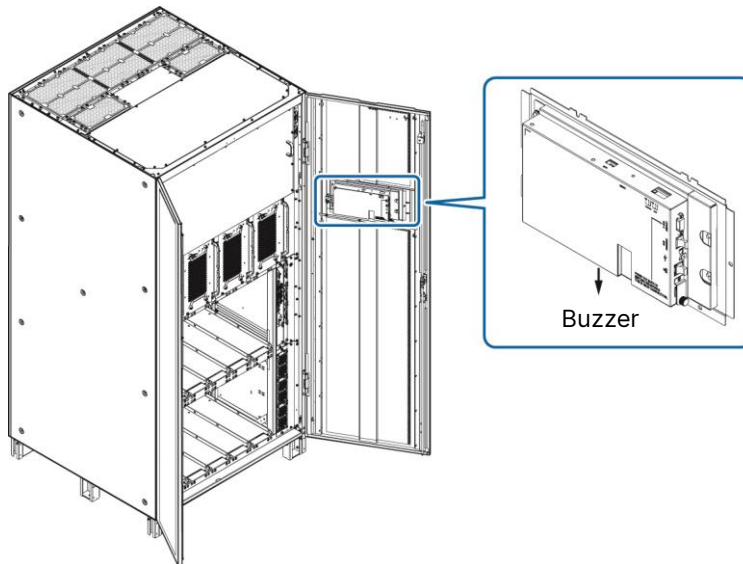

Figure 2-9: Buzzer Location

Table 2-1: Tri-color LED Indicator, UPS Operation Mode & Buzzer

Tri-color LED Indicator	Status	Meaning																		
Green	ON	<ul style="list-style-type: none"> It indicates that the UPS is operating in one of the following modes. <table border="1"> <thead> <tr> <th>UPS Operation Mode</th> <th>Text on the LCD Screen (upper-right corner)</th> </tr> </thead> <tbody> <tr> <td>On-Line Mode</td> <td>'On-Line'</td> </tr> <tr> <td>ECO Mode</td> <td>'ECO'</td> </tr> <tr> <td>Green Mode</td> <td>'Green'</td> </tr> <tr> <td>Clean Mode</td> <td>'Clean'</td> </tr> <tr> <td>Frequency Conversion Mode</td> <td>'Frequency Conversion'</td> </tr> </tbody> </table>	UPS Operation Mode	Text on the LCD Screen (upper-right corner)	On-Line Mode	'On-Line'	ECO Mode	'ECO'	Green Mode	'Green'	Clean Mode	'Clean'	Frequency Conversion Mode	'Frequency Conversion'						
		UPS Operation Mode	Text on the LCD Screen (upper-right corner)																	
		On-Line Mode	'On-Line'																	
		ECO Mode	'ECO'																	
		Green Mode	'Green'																	
		Clean Mode	'Clean'																	
		Frequency Conversion Mode	'Frequency Conversion'																	
Yellow	ON	<ul style="list-style-type: none"> It indicates that the UPS is operating in one of the following modes. <table border="1"> <thead> <tr> <th>UPS Operation Mode</th> <th>Text on the LCD Screen (upper-right corner)</th> </tr> </thead> <tbody> <tr> <td>Bypass Mode</td> <td>'Bypass'</td> </tr> <tr> <td>Battery Mode</td> <td>'Battery'</td> </tr> <tr> <td>Standby Mode</td> <td>'Standby'</td> </tr> <tr> <td>Softstart Mode</td> <td>'Softstart'</td> </tr> <tr> <td>Energy Recycle Mode</td> <td>'Energy Recycle'</td> </tr> </tbody> </table> <ul style="list-style-type: none"> It indicates a minor or medium warning message. <table border="1"> <thead> <tr> <th>Warning Level</th> <th>Buzzer Frequency</th> </tr> </thead> <tbody> <tr> <td>Minor</td> <td>It sounds 0.5 seconds every 3 seconds.</td> </tr> <tr> <td>Medium</td> <td>It sounds 0.5 seconds every second.</td> </tr> </tbody> </table>	UPS Operation Mode	Text on the LCD Screen (upper-right corner)	Bypass Mode	'Bypass'	Battery Mode	'Battery'	Standby Mode	'Standby'	Softstart Mode	'Softstart'	Energy Recycle Mode	'Energy Recycle'	Warning Level	Buzzer Frequency	Minor	It sounds 0.5 seconds every 3 seconds.	Medium	It sounds 0.5 seconds every second.
		UPS Operation Mode	Text on the LCD Screen (upper-right corner)																	
		Bypass Mode	'Bypass'																	
		Battery Mode	'Battery'																	
		Standby Mode	'Standby'																	
		Softstart Mode	'Softstart'																	
		Energy Recycle Mode	'Energy Recycle'																	
Warning Level	Buzzer Frequency																			
Minor	It sounds 0.5 seconds every 3 seconds.																			
Medium	It sounds 0.5 seconds every second.																			
Red	ON	<ul style="list-style-type: none"> It indicates a major warning message. <table border="1"> <thead> <tr> <th>Warning Level</th> <th>Buzzer Frequency</th> </tr> </thead> <tbody> <tr> <td>Major</td> <td>Long beep.</td> </tr> </tbody> </table>	Warning Level	Buzzer Frequency	Major	Long beep.														
		Warning Level	Buzzer Frequency																	
Major	Long beep.																			

Chapter 3 : Operation Modes

The UPS runs in nine basic operation modes, which are **On-Line** mode, **Battery** mode, **Bypass** mode, **Manual Bypass** mode, **ECO** mode, **Green** mode, **Clean** mode, **Frequency Conversion** mode and **Energy Recycle** mode.



NOTE:

1. The UPS must be connected with an external maintenance bypass cabinet (user-supplied, handled and configured by Delta service personnel). For information regarding the external maintenance bypass cabinet, please refer to **1.2 Connection Warnings**.
2. In this user manual, the meaning of Q1, Q2, Q3, Q4 and Q5 is shown as follows.

Code	Meaning
Q1	External Maintenance Bypass Cabinet's Input Switch
Q2	External Maintenance Bypass Cabinet's Bypass Switch
Q3	External Maintenance Bypass Cabinet's Manual Bypass Switch
Q4	External Maintenance Bypass Cabinet's Output Switch
Q5	External Battery Cabinet's Breaker

3. To enable the following operation modes, please refer to **6. UPS Operation** & **7. LCD Display & Settings**.

3.1 On-Line Mode

In On-Line mode, the main AC source supplies AC power via the external maintenance bypass cabinet's Input Switch (Q1) to the rectifier, and the rectifier converts the AC power to DC power and supplies the DC power to the inverter. In the meantime, the rectifier provides charging power to the batteries. After receiving the DC power, the inverter converts it into clean and stable AC power to the connected critical loads via the external maintenance bypass cabinet's Output Switch (Q4). During On-Line mode, the UPS's tri-color LED illuminates green and the text 'On-Line' appears in the upper right corner of the LCD screen.

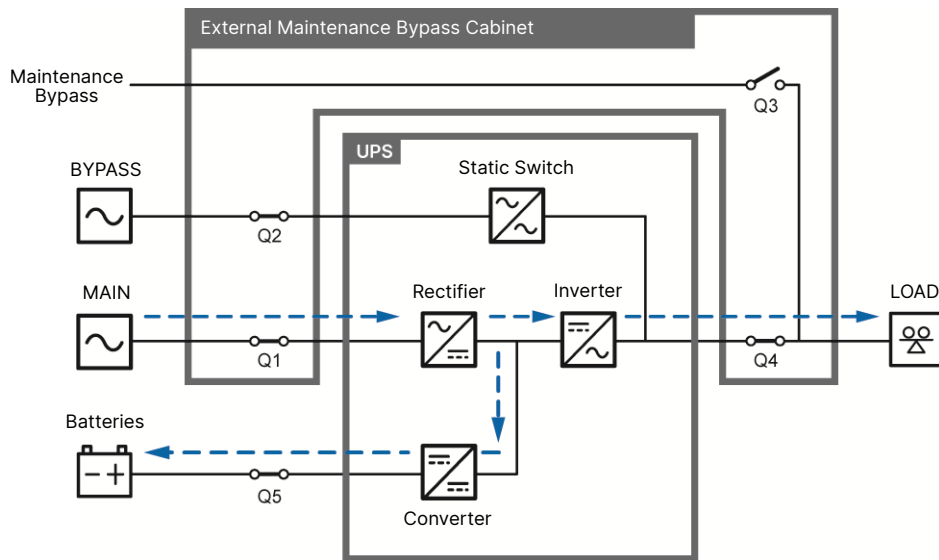

Figure 3-1: On-Line Mode Diagram

3.2 Battery Mode

The UPS transfers to Battery mode automatically if the main AC source is abnormal, for example, when unstable voltage or a power outage occurs. In Battery mode, the batteries provide DC power and the UPS converts it into AC power and supplies it to the connected critical loads via the external maintenance bypass cabinet's Output Switch (Q4). During the conversion process, output voltage remains the same. During Battery mode, the UPS's tri-color LED illuminates yellow and the text 'Battery' appears in the upper right corner of the LCD screen.

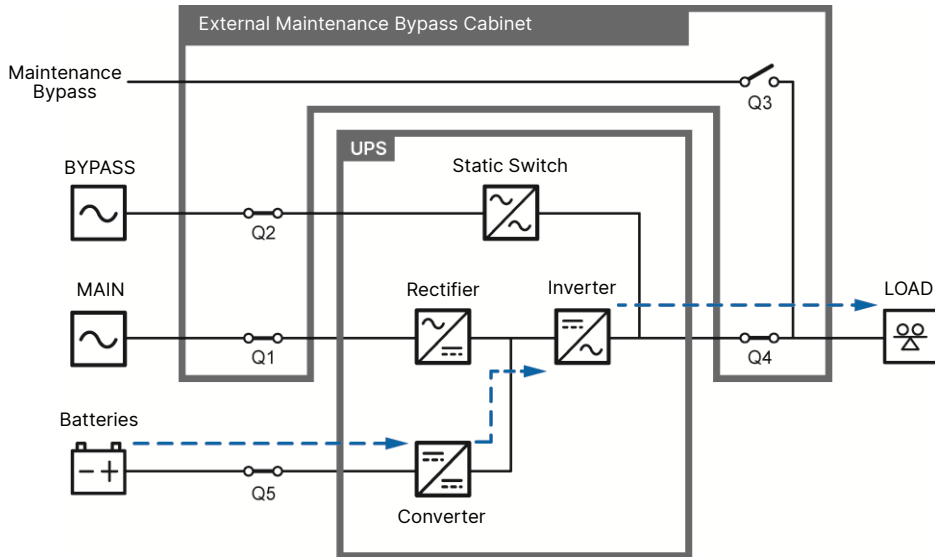

Figure 3-2: Battery Mode Diagram

3.3 Bypass Mode

When the inverter encounters abnormal situations such as over temperature, overload, short circuit, abnormal output voltage or low battery, it will automatically shut itself down. If the UPS detects the bypass input is normal, it will automatically switch to Bypass mode to protect the connected critical loads from power interruption. After the above-mentioned abnormalities are eliminated, the UPS will switch back to On-Line mode from Bypass mode. During Bypass mode, the UPS's tri-color LED illuminates yellow and the text **'Bypass'** appears in the upper right corner of the LCD screen.

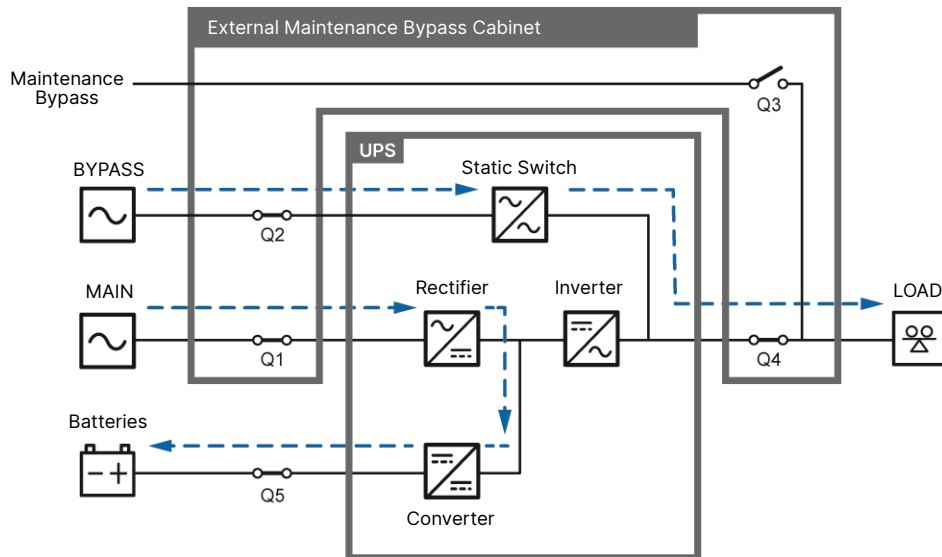

Figure 3-3: Bypass Mode Diagram

3.4 Manual Bypass Mode

When the UPS runs in Manual Bypass mode, the current only flows through the maintenance bypass so that the maintenance personnel can maintain the circuit inside the UPS. However, DO NOT touch any external maintenance bypass cabinet's terminal and bus bar which may carry high-voltage electricity. During Manual Bypass mode, the UPS's input power is completely cut off, and the critical loads are not protected. At the moment, the UPS's tri-color LED and LCD screen are both off.

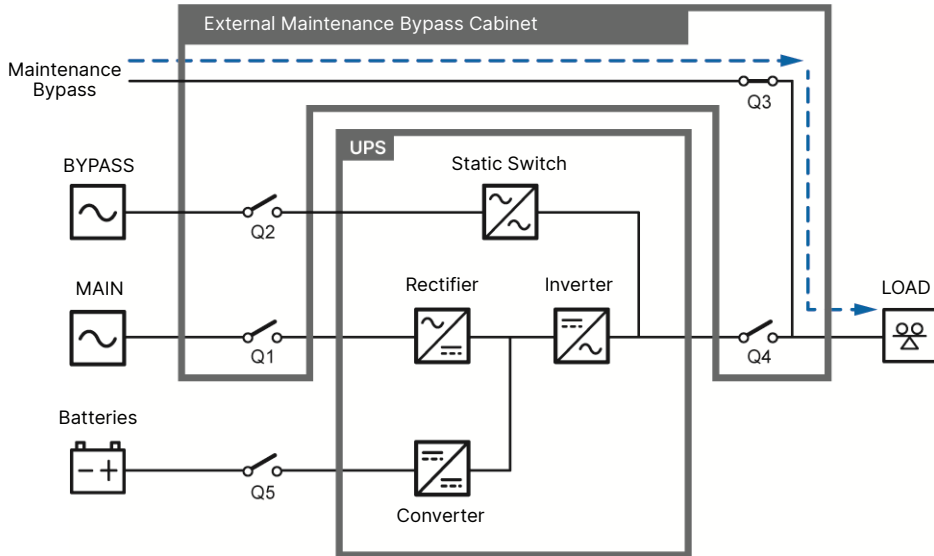

Figure 3-4: Manual Bypass Mode Diagram

3.5 ECO Mode

After the UPS is manually set as ECO mode via the LCD, the UPS will work in Bypass mode if bypass input voltage and frequency are within $\pm 10\%$ of the rated voltage and ± 5 Hz of the rated frequency respectively. Otherwise, the UPS will run in On-Line mode. During ECO mode, the UPS's tri-color LED illuminates green and the text 'ECO' appears in the upper right corner of the LCD screen.

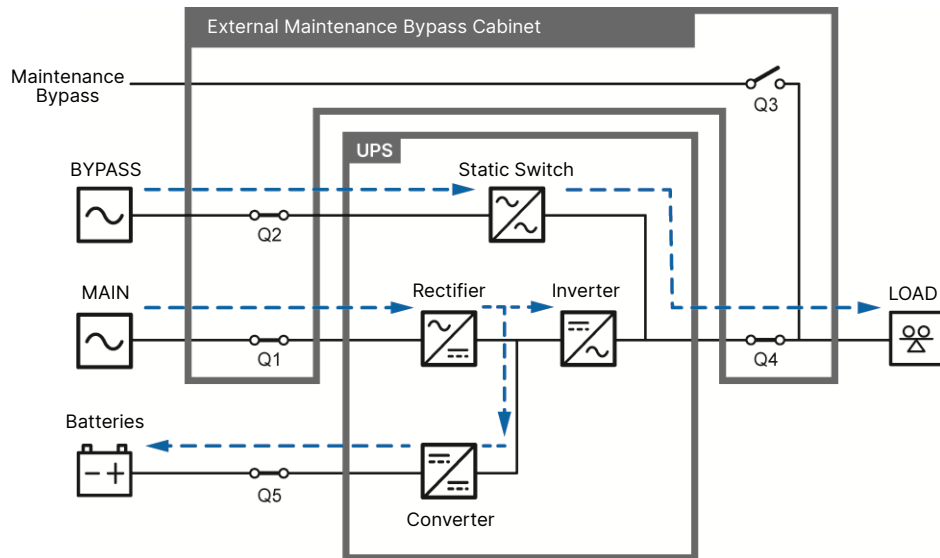

Figure 3-5: ECO Mode Diagram

3.6 Green Mode

After the UPS is manually set as Green mode via the LCD, the system will automatically detect the output status (i.e. total load capacity %) to decide which specific power module(s) should be fully powered on or idle in order to achieve higher efficiency of the UPS. During Green mode, the UPS's tri-color LED illuminates green and the text 'Green' appears in the upper right corner of the LCD screen.

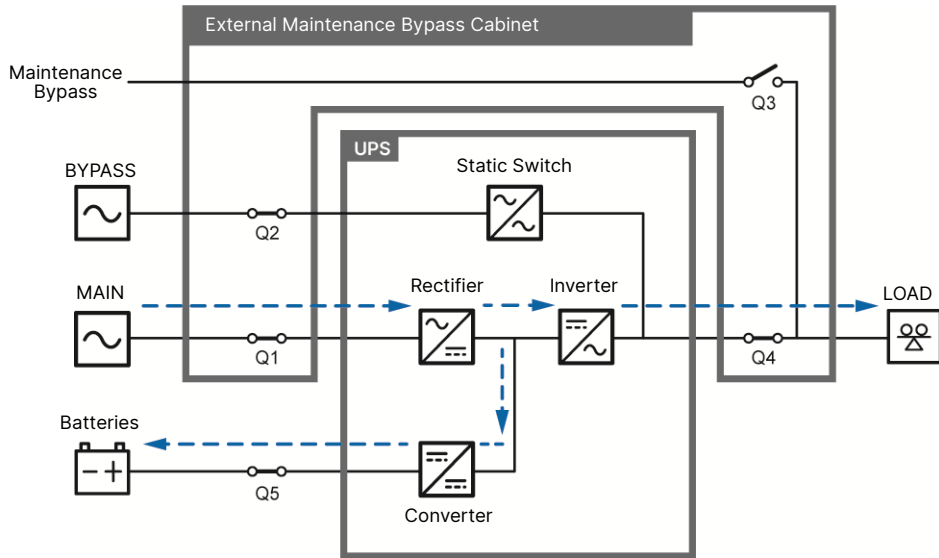

Figure 3-6: Green Mode

3.7 Clean Mode

After the UPS is manually set as Clean mode via the LCD, the system will automatically detect the output status to let the inverter provide active filter function to compensate harmonics, correct power factor and reduce bypass reactive current to improve overall power quality. During Clean mode, the UPS's tri-color LED illuminates green and the text 'Clean' appears in the upper right corner of the LCD screen.

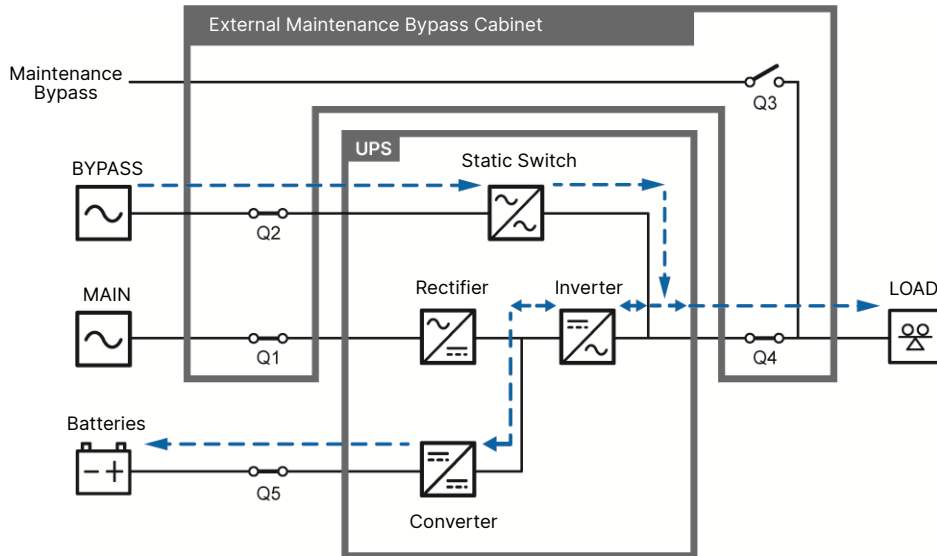

Figure 3-7: Clean Mode

3.9 Energy Recycle Mode



NOTE:

1. Energy Recycle mode is only applicable to single unit application.
2. Only qualified personnel can perform the following operation.

Energy Recycle mode is only applicable to UPS self-test only. Without connection to any critical loads, the UPS can execute current test under full load condition. Before you activate Energy Recycle mode, please make sure that the external maintenance bypass cabinet's Manual Bypass Switch (Q3) and Output Switch (Q4) as well as each external battery cabinet's battery breaker (Q5) are in the **OFF** status. During Energy Recycle mode, the UPS's tri-color LED illuminates yellow and the text '**Energy Recycle**' appears in the upper right corner of the screen.

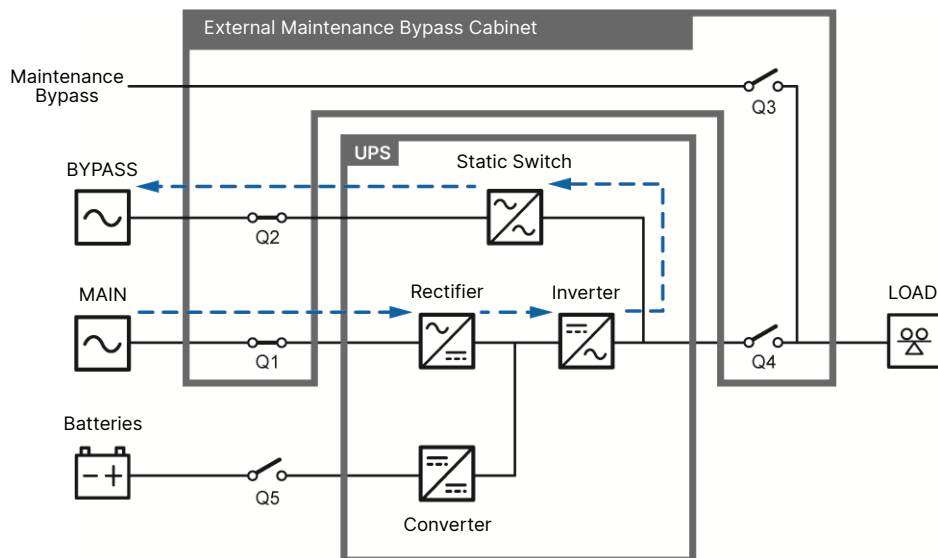

Chapter 4 : Communication Interfaces

The communication interfaces are located at two different places. One is on the front of the UPS with its right front door open and the other is at the rear of the touch panel. Please refer to *Figure 2-4*.



NOTE:

1. It is suggested that the wire size of cable connected to any dry contact should be 0.519 mm² (20 AWG) or 0.325 mm² (22 AWG).
2. For signal communication, twisted wires should be used, isolated from the power and labelled for inspection and maintenance.

4.1 Communication Interfaces (I): on the Front of the UPS with Its Right Front Door Open

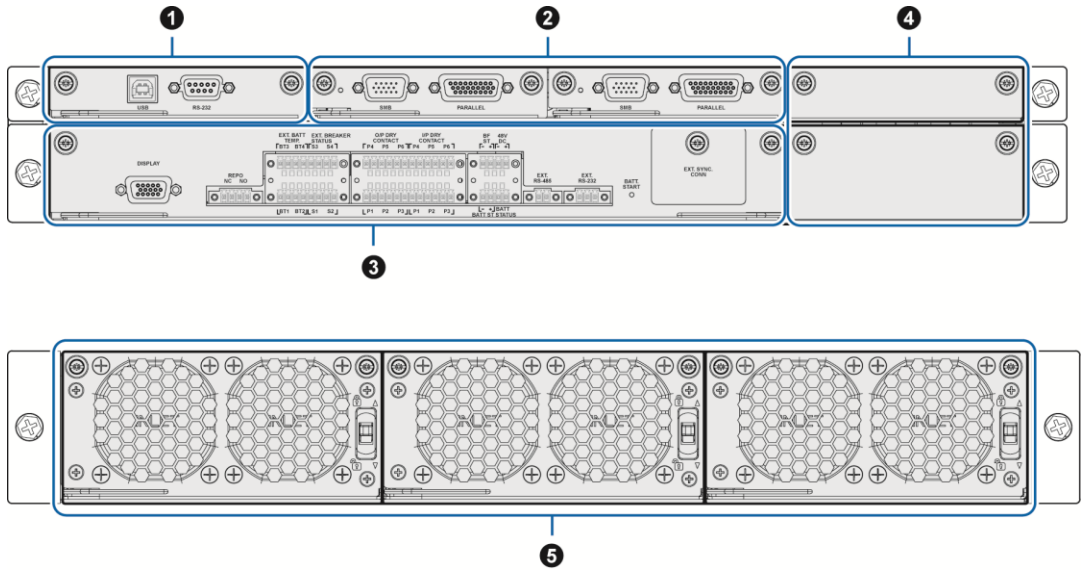

No.	Item	Q'ty
1	System Control Card	1 PC
2	Parallel Communication Card	2 PCS
3	Dry Contact Card	1 PC
4	SMART Slot (for optional Multifunctional Communication Card (MFC))	2 PCS
5	Auxiliary Power Card	3 PCS

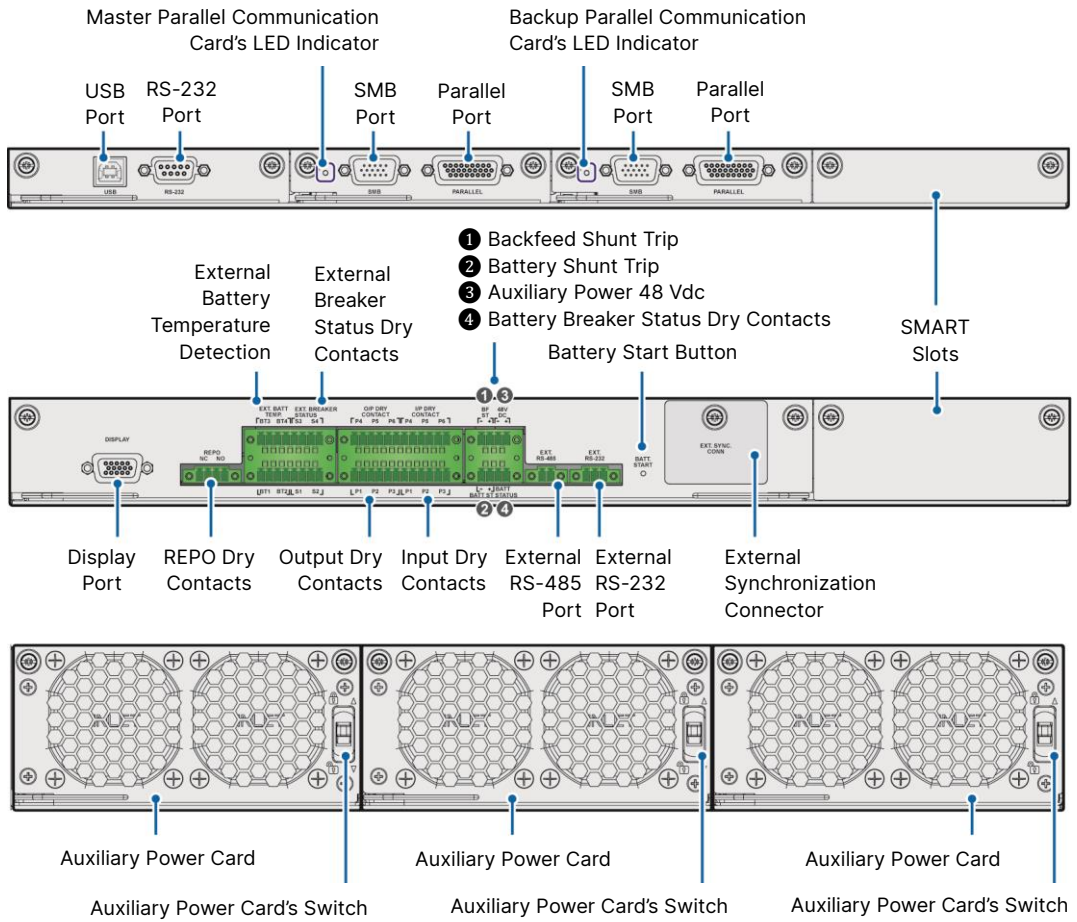

Figure 4-1: Communication Interfaces (I)

4.1.1 USB Port & RS-232 Port

The USB port & RS-232 port are available for authorized service personnel.

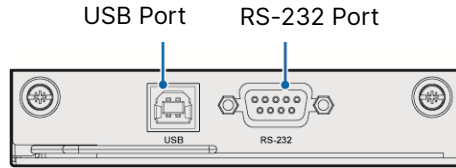

Figure 4-2: USB Port & RS-232 Port

4.1.2 Parallel Communication Cards

The UPS has two parallel communication cards, which are master parallel communication card and backup parallel communication card. Each card has one LED indicator.

If both cards work normally, the master parallel communication card's LED indicator will illuminate green and the backup parallel communication card's LED indicator will illuminate yellow.

If one card works normally and the other works abnormally, the normal card's LED indicator will illuminate green and the abnormal card's LED indicator will illuminate red.

During the initialization process, both cards' LED indicators flash yellow.

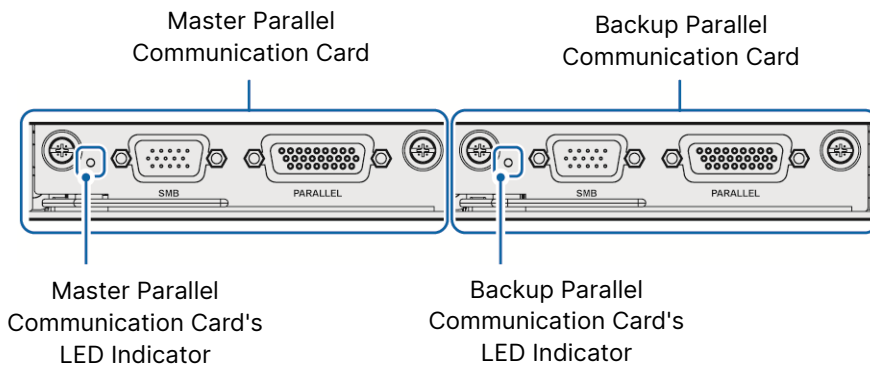

Figure 4-3: Parallel Communication Cards

4.1.3 Parallel Ports

The parallel ports are used to connect parallel UPSs to increase system capacity and redundancy.

You can parallel a maximum of 8 UPS units and the output power of each UPS is determined by the number of power modules.

Only UPSs with the same capacity, voltage, frequency and version can be paralleled. Please daisy-chain the parallel UPSs with the provided parallel cables only.

Please refer to *5.4.4 Parallel Units Wiring* to route the parallel cables.



WARNING:

1. One parallel cable is provided in each UPS's accessory package. Using non-Delta parallel cables to parallel the UPSs may cause failure, malfunctions and accidents.
2. Please remove the parallel cable and SMB cable before removing the parallel communication card.

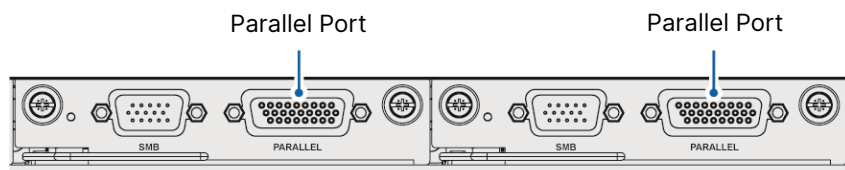

Figure 4-4: Parallel Ports

4.1.4 Synchronized Multiple Bus (SMB) Ports

The synchronized multiple bus (SMB) ports are used to synchronize the output frequency and phase of each multiple-bus system to ensure that two or more systems are switched in synchronization.



NOTE:

1. The SMB cable is optional.
2. Please remove the parallel cable and SMB cable before removing the parallel communication card.

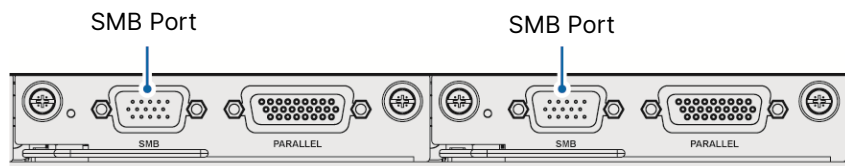

Figure 4-5: SMB Ports

4.1.5 Display Port

Before shipment, the display port has been connected to the 10" touch panel with the designated cable in Delta factory.

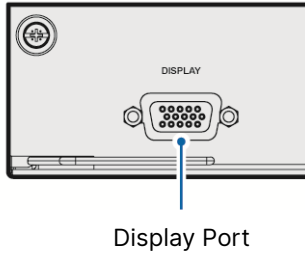

Figure 4-6: Display Port

4.1.6 REPO Dry Contacts

Connect the REPO dry contacts to a user-supplied switch so you can remotely shut down the UPS when an emergency occurs. Both of the normally open (NO) and normally closed (NC) dry contacts shown below must be connected.



Figure 4-7: REPO Dry Contacts

4.1.7 External Battery Temperature Detection

You can use the external battery temperature detection (BT1, BT2, BT3 and BT4) to detect a maximum of four external battery cabinets' temperature. You need to purchase the battery cabinet temperature sensor cable (optional).

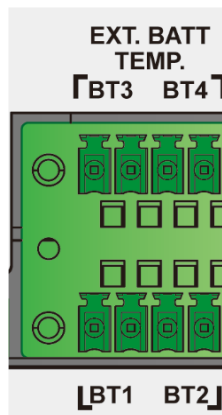

Figure 4-8: External Battery Temperature Detection

4.1.8 External Breaker Status Dry Contacts

There are four sets of external breaker status dry contacts (S1, S2, S3 and S4), which can be used to respectively detect the status of external maintenance bypass cabinet's input, bypass, manual bypass and output switches. Please follow the table below to connect the dry contacts to normally open (NO) or normally closed (NC) devices. Please follow the table below to connect the dry contacts to normally open (NO) or normally closed (NC) devices.



NOTE:

The normally closed (NC) or normally open (NO) devices connected to these four sets of external breaker status dry contacts should only have the function of switch without any AC or DC power.

Type	Connection
Dry Contact_ S1	Normally closed (NC) device
Dry Contact_ S2	Normally closed (NC) device
Dry Contact_ S3	Normally open (NO) device
Dry Contact_ S4	Normally closed (NC) device

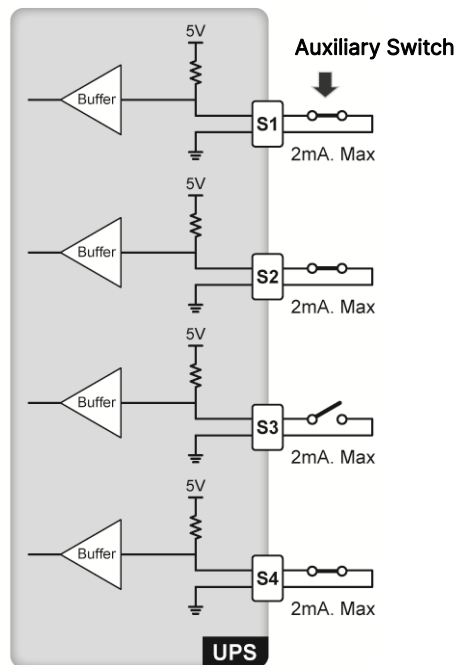
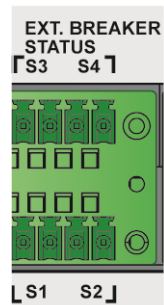

Figure 4-9: External Breaker Status Dry Contacts & Schematic

4.1.9 Output Dry Contacts

There are six sets of programmable output dry contacts (P1 ~ P6). Please use the touch panel to set each dry contact as normally open (NO) or normally closed (NC). Each dry contact can be assigned a specific event. Six out of thirty-four events can be assigned according to your applications. Please refer to the table below and **7.6.6 Dry Contact Setting**.

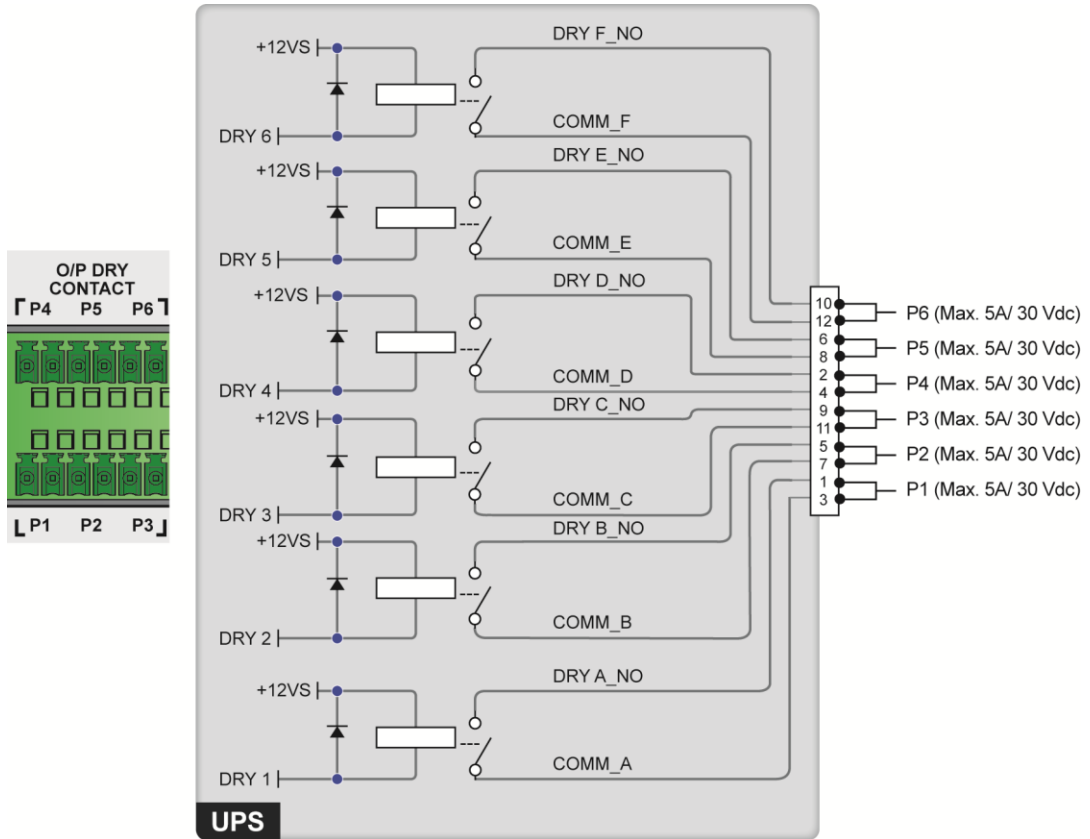

Figure 4-10: Output Dry Contacts & Schematic

No.	Event	Description
1	None	No set-up.
2	Load On Inverter	The UPS works in On-Line mode.
3	Load On Bypass	The UPS works in Bypass mode.
4	Load On Battery	When the main AC source fails, the batteries supply power to the critical loads.

No.	Event	Description
5	Battery Low	When the UPS runs in Battery mode, the battery voltage is lower than the setup limit (default: 440 Vdc).
6	Bypass Input Abnormal	The bypass voltage, frequency or phase sequence is abnormal.
7	Battery Test Fail	During the battery test, the battery voltage is out of the setup limit.
8	Internal Comm. Fail	The #n power module's internal communication is abnormal.
9	External Parallel Comm. Fail (For parallel application only)	In parallel mode, parallel communication is abnormal.
10	Output Overload/ Warning Shutdown	The UPS is overloaded or the UPS shuts down to let the bypass supply power to the critical loads.
11	EPO Activated	The EPO button is pressed to urgently power off the UPS.
12	Load On Manual Bypass	The external maintenance bypass cabinet's Manual Bypass Switch (Q3) is turned on and the UPS transfers to Manual Bypass mode.
13	Battery Over Temperature	The external battery cabinet's temperature is too high.
14	Output Voltage Abnormal	The output voltage is abnormal.
15	Battery Need Replacement	The battery replacement date is due.
16	Bypass Over Temperature	The bypass static switch temperature is too high.
17	Bypass Static Switch Fault	The bypass static switch has an open/ short issue.
18	UPS Over Temperature	The UPS temperature is too high.
19	Battery Breaker Shunt Trip	When the EPO button is pressed, the UPS will send a signal to the connected external shunt trip device to cut off the battery power.

No.	Event	Description
20	Backfeed Protection	When the UPS's bypass SCR has a short-circuit issue, the UPS will send a signal to the connected external shunt trip device to cut off the backfeed voltage.
21	General Alarm	When any UPS alarm occurs, the UPS will send a signal.
22	Main Input Abnormal	The main input is abnormal.
23	Input Neutral Disconnect	The main input's neutral is not connected.
24	PFC General Alarm	When the UPS's internal PFC has any alarm, it will send a signal.
25	INV General Alarm	When the UPS's internal INV has any alarm, it will send a signal.
26	Fan Failure Alarm	Alarm due to fan abnormality.
27	Main Input Switch Open	The external maintenance bypass cabinet's Input Switch (Q1) is not turned on.
28	Bypass Input Switch Open	The external maintenance bypass cabinet's Bypass Switch (Q2) is not turned on.
29	Output Switch Open	The external maintenance bypass cabinet's Output Switch (Q4) is not turned on.
30	Battery Switch Open	The external battery cabinet's breaker (Q5) is not turned on.
31	Battery Disconnect	The UPS doesn't detect the battery voltage.
32	Battery Abnormal Alarm - BMS	The UPS receives the BMS's alarm.
33	INV Failure Shutdown	The UPS shuts down because the INV output voltage is abnormal.
34	Battery Low Shutdown	The UPS shuts down because the battery voltage is too low.

4.1.10 Input Dry Contacts

There are six sets of programmable input dry contacts (P1 ~ P6). The input dry contacts allow the UPS to receive external signals from peripheral devices and let the UPS response accordingly. Please use the touch panel to set each dry contact as normally open (NO) or normally closed (NC). Each input dry contact can be assigned a specific event. Six out of fifteen events can be assigned according to your applications. Please refer to the table below and **7.6.6 Dry Contact Setting**.

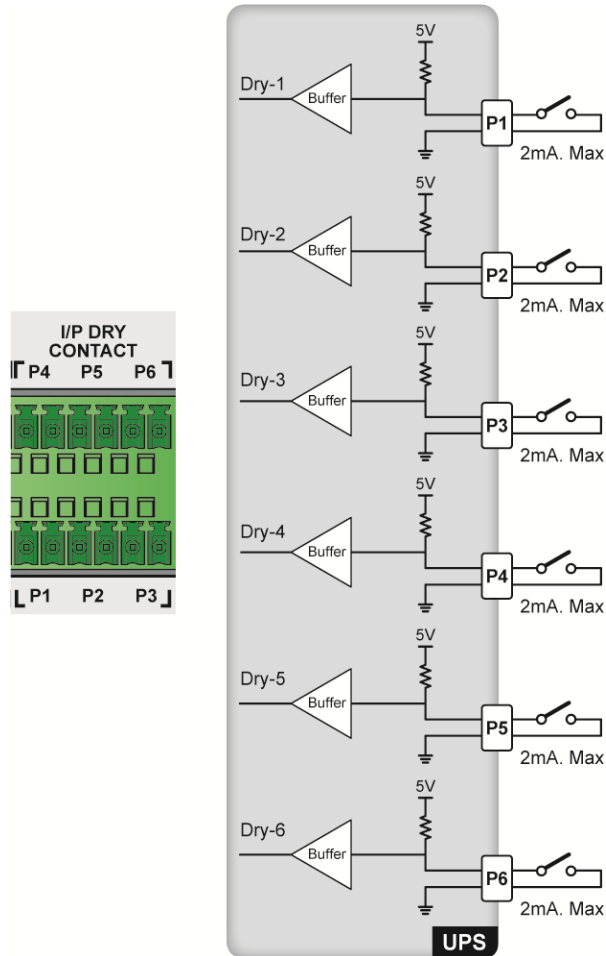

Figure 4-11: Input Dry Contacts & Schematic

No.	Event	Description
1	None	No set-up.
2	Generator Status	Generator status detection.
3	Battery Ground Fail	Battery leakage detection.

No.	Event	Description
4	External Battery Fuse Open	The external battery fuse is blown.
5	Active Standby	In Bypass mode: the UPS will remain to run in Bypass mode. In On-Line mode: the UPS will transfer to Bypass mode immediately. In ECO mode: the UPS will transfer to Bypass mode immediately. In Battery mode: the UPS will transfer to Standby mode immediately.
6	Battery Abnormal Shutdown	In On-Line mode: the UPS will issue a battery abnormal warning. In Battery mode: the UPS will transfer to Bypass or Standby mode immediately.
7	Input Transformer OTW	Input transformer over temperature warning.
8	Output Transformer OTW	Output transformer over temperature warning.
9	Charger Off* ¹	Turn off the charger.
10	Major Battery Abnormal Alarm	Alarm due to detection of major fault from the battery management system.
11	Minor Battery Abnormal Alarm	Alarm due to detection of minor fault from the battery management system.
12	Force Battery Mode	Force the UPS to run in battery mode.
13	External Battery Breaker Detection	Status detection of the External Battery Cabinet's Breaker (Q5).
14	Force Sync External Source	Force the UPS to synchronize with an external voltage source. Please refer to 4.1.17 External Synchronization Connector .
15	Input Current Limit Stage Setting	Limit the input current to a specific Ampere (adjustable in a certain range). Please refer to 7.6.3 Input & Output Setting .



NOTE:

*1 If you use non-Delta lithium-ion batteries, you must use the LCD to set up **Charger Off**; please refer to **7.6.6 Dry Contact Setting**. For settings relevant to the non-Delta lithium-ion batteries, please refer to **7.6.4 Battery & Charging Setting**. For more information, please contact Delta customer service.

4.1.11 Backfeed Shunt Trip Function

When the UPS's bypass SCR has a short-circuit issue, the UPS will provide 48 Vdc isolated power to the connected external backfeed contactor to cut off the backfeed voltage.



NOTE:

When the system diagnoses backfeed shunt trip, please cut off the power supply and use an electric meter to confirm that there is no power at the input end before performing maintenance.

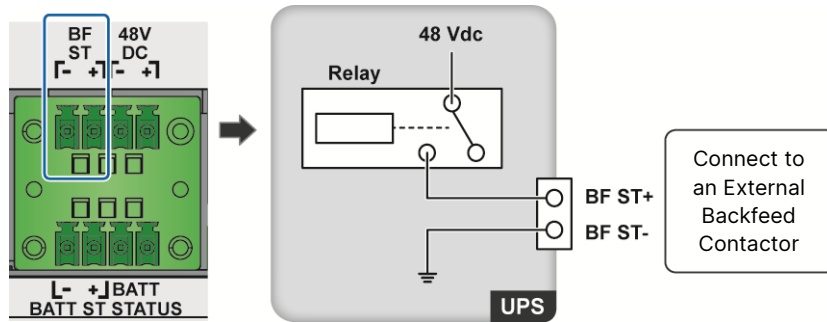

Figure 4-12: Backfeed Shunt Trip & Schematic

4.1.12 Battery Shunt Trip Function

When the external REPO button is pressed, the UPS will provide 48 Vdc isolated power to the connected external shunt trip device to cut off the battery power.

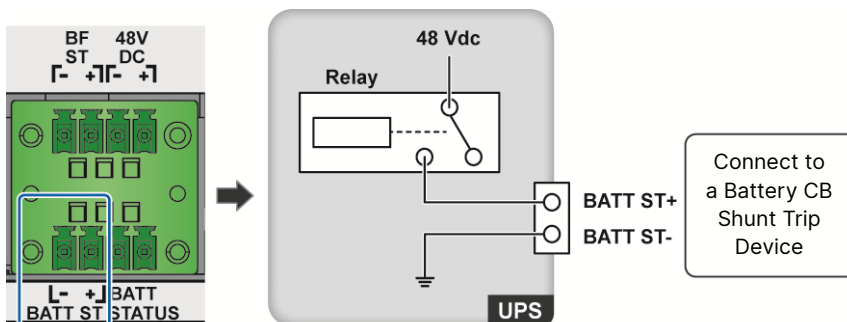

Figure 4-13: Battery Shunt Trip & Schematic

4.1.13 Auxiliary Power 48 Vdc

For application, you can use the interfaces to either provide 48 Vdc isolated power (Max. 2A) for external use or connect an external device to cut off its circuit breaker.

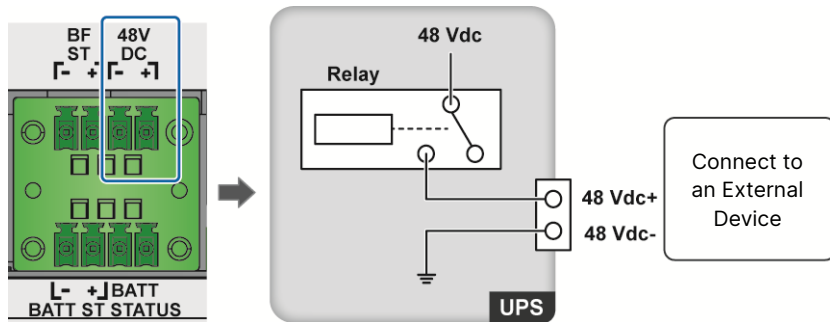

Figure 4-14: Auxiliary Power 48 Vdc Application & Schematic

4.1.14 Battery Breaker Status Dry Contacts

The battery breaker status dry contacts are used to detect the status of the external battery cabinet's breaker (Q5). For detection, please remove the short wire of the dry contacts and connect user-supplied auxiliary switches to the dry contacts (see the figure below). If you don't execute the above-mentioned setup, the default setting of the external battery cabinet's breaker (Q5) shown on the LCD will be ON.

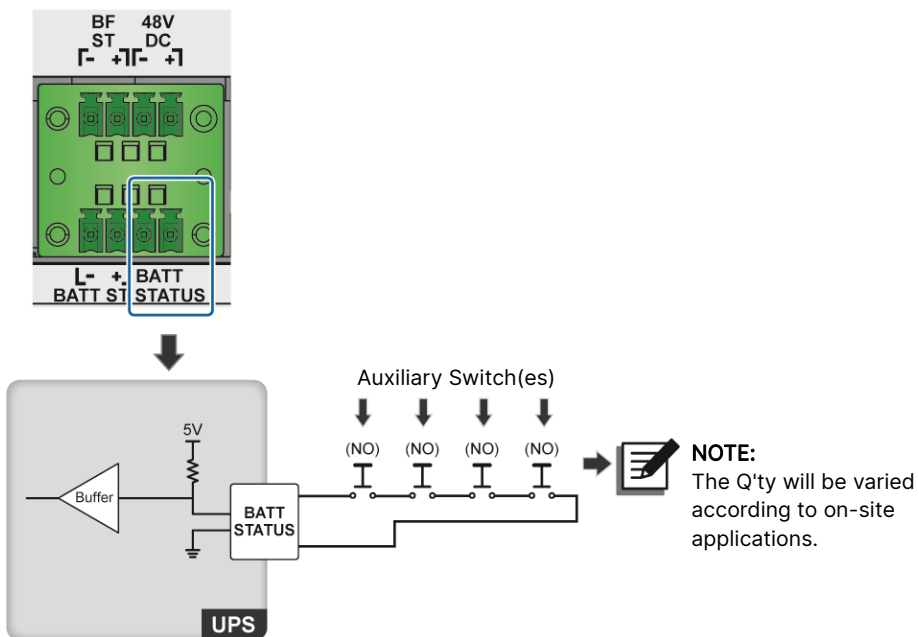

Figure 4-15: Battery Breaker Status Dry Contacts & Schematic

4.1.15 External RS-485 & External RS-232 Ports

The external RS-485 & external RS-232 ports are reserved.

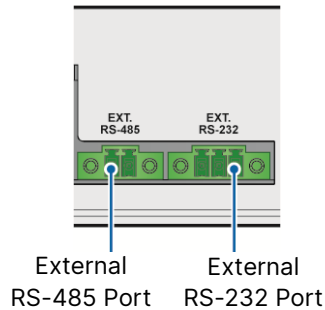
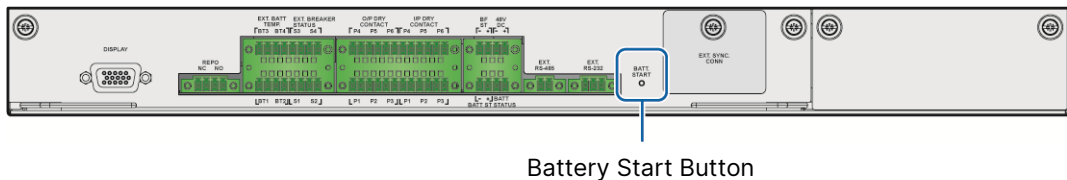

Figure 4-16: External RS-485 & External RS-232 Ports

4.1.16 Battery Start Button

To activate battery mode, you need to press the battery start button shown below. Please refer to **6.2.2 Battery Mode Start-up Procedures**.



Battery Start Button

Figure 4-17: Battery Start Button

4.1.17 External Synchronization Connector

The external synchronization connector helps to synchronize the output frequency and phase of an external voltage source (ex. generator, UPS, grid, etc.). The cables used for connection must have a minimum rating of 600V. For three-phase four-wire power system, use the cables to connect (1) N phase and white connector and (2) L1 phase and red connector.

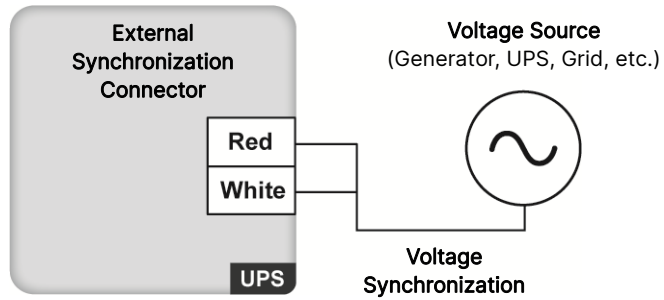

Figure 4-18: External Synchronization Connector Application

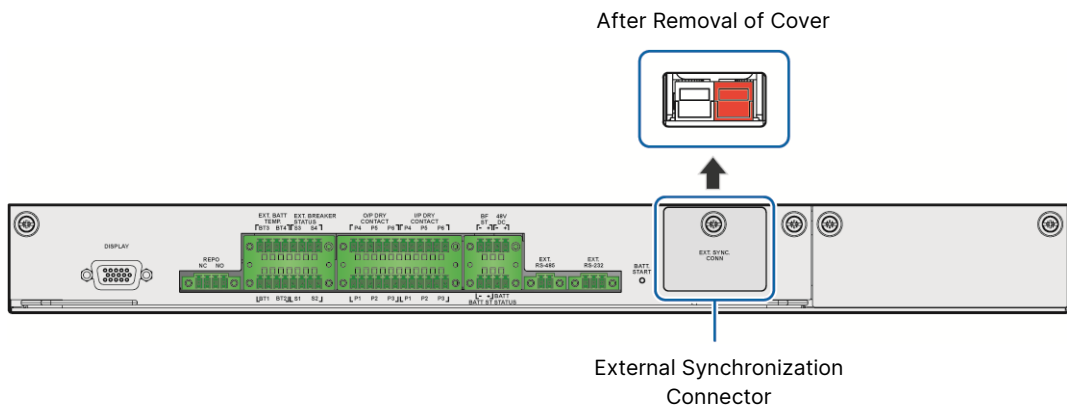

Figure 4-19: External Synchronization Connector

4.1.18 SMART Slots

1. You can install the optional relay I/O card (for dry contact expansion) into the SMART slot. For installation and application, please contact Delta customer service.

Regarding cable routing for the relay I/O card's dry contacts, it is the same as the communication interfaces. Please refer to **4.3 Cable Routing for the Communication Interfaces**.

2. If you use the Delta lithium-ion batteries, you must install the optional multifunctional communication card (MFC) into the SMART slot to monitor the battery status. For settings and information relevant to the Delta lithium-ion batteries, please refer to **7.6.4 Battery & Charging Setting** and **8. Optional Accessories**. For more information, please contact Delta customer service.

Please use the Ethernet cable*1 to connect the MFC's parallel ports. The Ethernet cable routing is the same as the UPS parallel cable routing (see **Figure 5-17**).



NOTE:

*1 One Ethernet cable is provided in each package of the optional multi-functional communication card (MFC).

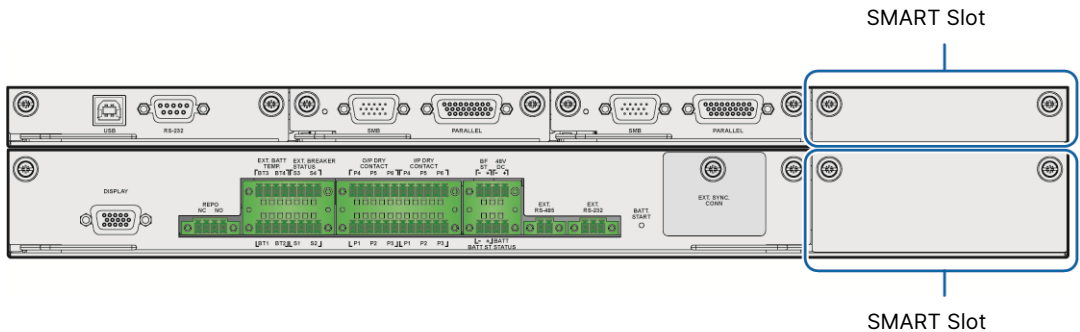

Figure 4-20: SMART Slots

4.1.19 Auxiliary Power Cards

The UPS has three hot-swappable auxiliary power cards. Each card has its own switch. The switch is turned on by default. If the auxiliary power card is damaged and needs replacement, please turn off the switch first.



WARNING:

When replacing, remove only one auxiliary power card at a time to avoid power interruption.

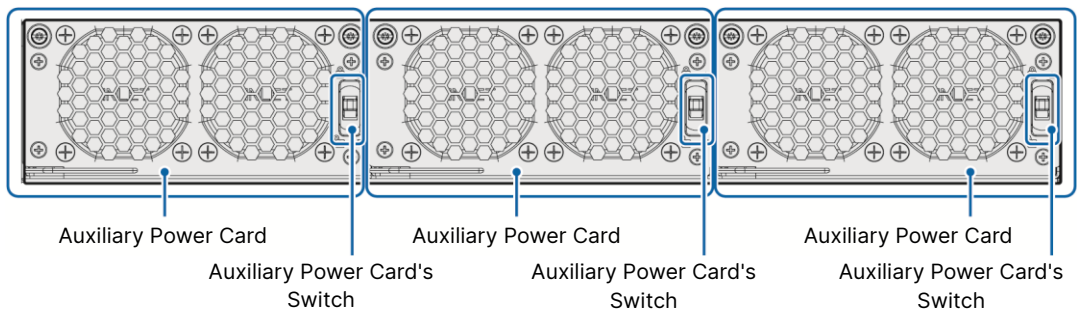

Figure 4-21: Auxiliary Power Cards

4.2 Communication Interfaces (II): at the Rear of the Touch Panel

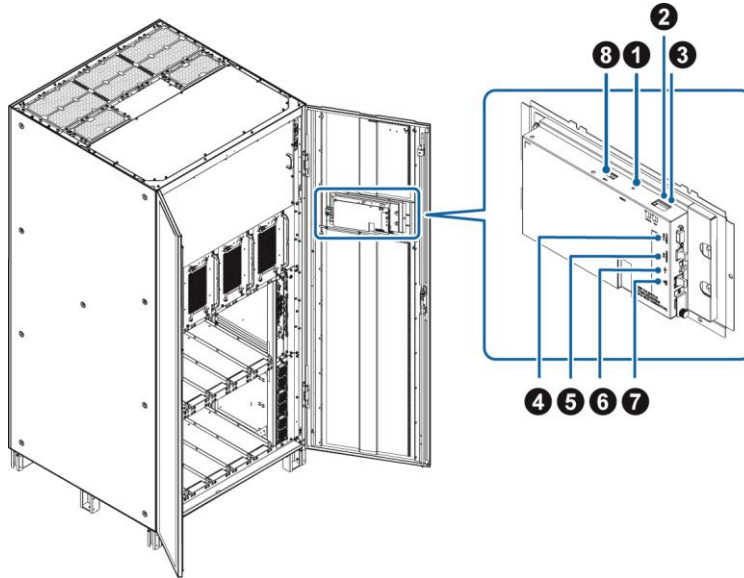



Figure 4-22: Communication Interfaces (II)

No.	Item	Description
①	RESET	Press the RESET button to restart the LCD.
②	MODBUS (RS-485 Port)	<ol style="list-style-type: none"> 1. Provision of Modbus RTU communication service. 2. Connect the port to a user-supplied monitoring system.
③	BMS	Reserved.
④	DISPLAY	Before shipment, the DISPLAY port has been connected.
⑤	EMS/ CONSOLE	Connect the port to a user-supplied environmental monitoring system or Delta EnviroProbe 1000 (optional).
⑥	 (USB Port × 1)	Connect a user-supplied USB flash drive to the port to (1) upgrade the UPS and LCD's firmware and (2) download event logs.
⑦	 (Network Port)	<ol style="list-style-type: none"> 1. Provision of network communication service (including SNMP, Modbus TCP, HTTP, HTTPS, etc.). 2. Connect the port to a user-supplied monitoring system.
⑧	EPO	Before shipment, the EPO port has been connected.

4.3 Cable Routing for the Communication Interfaces

Only top cable entry is allowed for the communication interfaces, please follow the steps below.

Step 1

Open the ① UPS's left and right front doors. Remove the ② top cover and ③ wiring terminal cover.

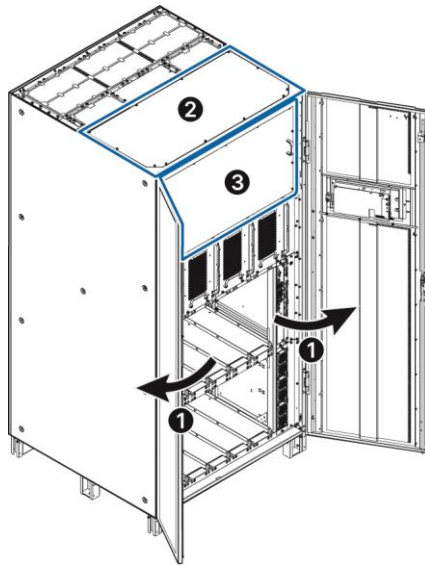

Figure 4-23: Open the Left & Right Front Doors and Remove the Top Cover & Wiring Terminal Cover

Step 2

Follow **1.1 Installation Warnings** and on-site requirements to drill a hole on the top cover and install conduits (user-supplied) on it. The opening size on the top cover should be defined by users. After completion, re-install the top cover. This helps to prevent foreign objects from falling into the cabinet.

Drill a Hole on the Top Cover

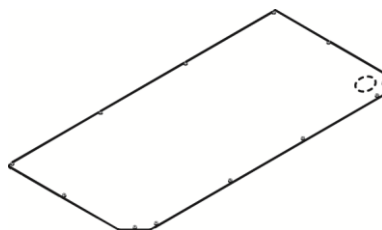

Figure 4-24: Drill a Hole, Install Conduits (User-supplied) and Reinstall the Top Cover

Step 3

Route the cables from the user-supplied conduits and ① snap bushings, use the cable ties (user-supplied) to fix the cables on the ② wire mounts, and connect the cables to the ③ communication interfaces (I) and ④ communication interfaces (II).

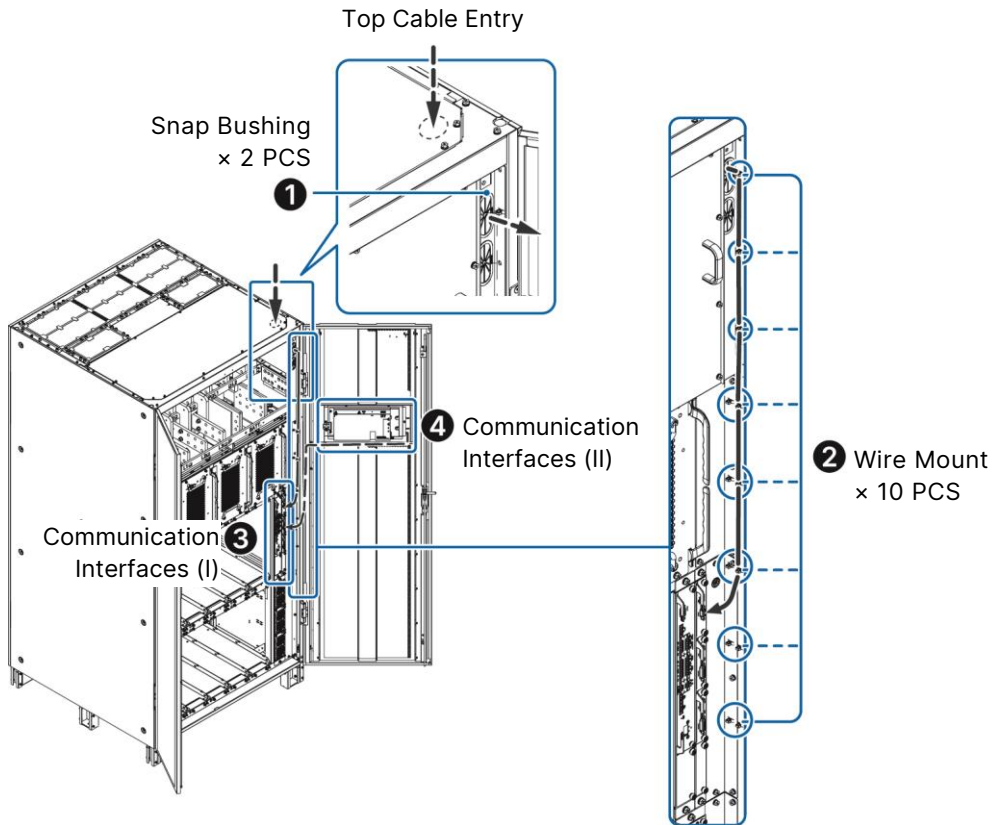

Figure 4-25: Top Cable Entry for the Communication Interfaces (I) & (II)



NOTE:

1. Please follow local and national electrical codes to select cable sizes and install proper conduits and bushings for cable protection.
2. Only when **5.3 UPS Installation** is completed can you perform wiring.
3. Cable ties are user-supplied and the quantity depends on on-site requirements.

Chapter 5 : Installation and Wiring

5.1 Before Installation and Wiring

- Please read this user manual thoroughly before installation, wiring and operation. Only authorized Delta engineers or service personnel can perform installation, wiring, panel & cover removal, maintenance and operation. If you want to execute any action mentioned above by yourself, the action must be under the supervision of authorized Delta engineers or service personnel. If you use a forklift or other equipment to move the UPS, please make sure its load bearing is sufficient. Please refer to **Table 5-1**.
- The UPS must be connected to at least one external battery cabinet (handled and configured by Delta service personnel). Please refer to **5.5 External Battery Cabinet Connection Warnings** for relevant information.
- The UPS must be connected with an external maintenance bypass cabinet (user-supplied, handled and configured by Delta service personnel). For information regarding the external maintenance bypass cabinet, please refer to **1.2 Connection Warnings**.

5.2 Installation Environment

- Install the UPS indoors. Do not place it outdoors.
- Make sure that transportation routes (e.g. corridors, door gates, elevators, etc.) and installation area can accommodate and bear the weight of the UPS, external maintenance bypass cabinet, external battery cabinet(s) and handling equipment. Please refer to **Table 5-1** for floor weight loading information.

Table 5-1: UPS Floor Weight Loading Table

UPS Capacity	750kVA/ 750kW	875kVA/ 875kW	1000kVA/ 1000kW	1125kVA/ 1125kW	1250kVA/ 1250kW
Power Module Q'ty	6	7	8	9	10
UPS Net Weight	1258 kg (2773.42 lb)	1318 kg (2905.69 lb)	1378 kg (3037.97 lb)	1438 kg (3170.25 lb)	1498 kg (3302.52 lb)
Floor Weight Loading	1258 kg/m ² (257.66 lb/ft ²)	1318 kg/m ² (269.95 lb/ft ²)	1378 kg/m ² (282.24 lb/ft ²)	1438 kg/m ² (294.53 lb/ft ²)	1498 kg/m ² (306.81 lb/ft ²)

- The UPS only allows cable entry from the top. Please leave adequate space on the top of the UPS to allow cable entry.
- Ensure that the installation area is spacious enough for ventilation, wiring and maintenance. Install the external battery cabinet next to the UPS. For the UPS clearance, Delta suggests the following:
 1. Keep a minimum distance of 1000 mm (39.37") from the front of the UPS for maintenance and ventilation.
 2. Keep a minimum distance of 500 mm (19.69") from the top of the UPS for maintenance, wiring and ventilation.



NOTE:

Dust filters have been installed on the inner side of the UPS's front doors before shipment.

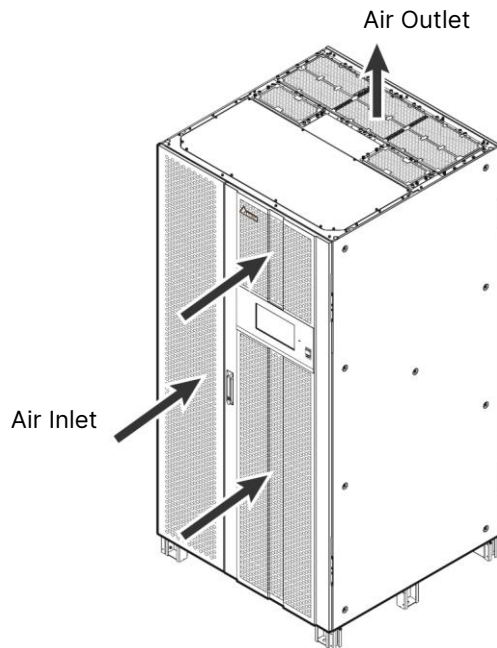

Figure 5-1: Air Inlet & Outlet Direction



WARNING:

1. Do not use air conditioners or similar equipment to blow into the top of the UPS.
 2. Do not hinder ventilation of the UPS.
- Keep the installation area clean. Please note that wiring routes must be hermetic to prevent possible damage from rodents.
 - Keep the installation area's temperature around 25°C (77°F) and humidity within 95%. The highest operating altitude is 1000 m (3280.84 ft) above sea level.

- For safety concerns, Delta suggests the following:
 1. Equip surroundings of the installation area with CO₂ or dry powder fire extinguishers.
 2. Install the UPS in an environment where fireproof materials are used to construct the walls, floors and ceilings.
 3. Install the UPS on a floor that is made of noncombustible materials.
- Do not allow unauthorized personnel to enter the installation area and assign specified personnel to keep the UPS keys.

5.3 UPS Installation



NOTE:

1. Please use appropriate equipment (e.g. forklift) to move the UPS.
2. If you want to move the UPS, do not install any power module in it.

Please follow the steps below:

Step 1

Before installing the UPS in a designated installation area, please double-check whether the area's floor weight loading is sufficient to bear the UPS, external maintenance bypass cabinet, external battery cabinet(s) and handling equipment (e.g. forklift) to avoid accidents. The weight of the UPS without power modules is 898 kg (1979.75 lb). For floor weight loading information, please refer to **Table 5-1**. For location of the center of gravity (COG), please see the figure below.

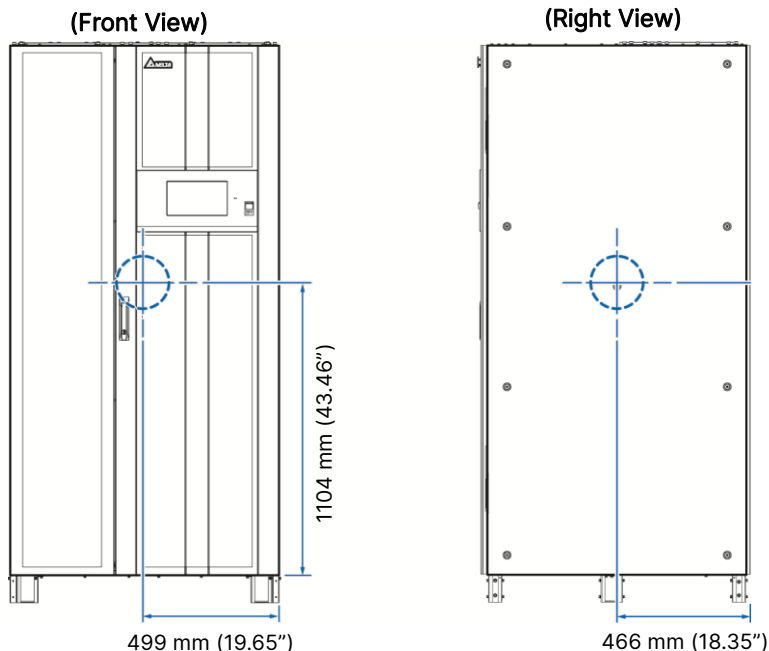

Figure 5-2: Center of Gravity

If the UPS needs lifting by a crane, qualified service personnel should provide M16 lifting eye bolts and follow the figure below to install them on the UPS (tightening torque: 250 ± 10 kgf-cm (217 ± 8.7 lb-in)).

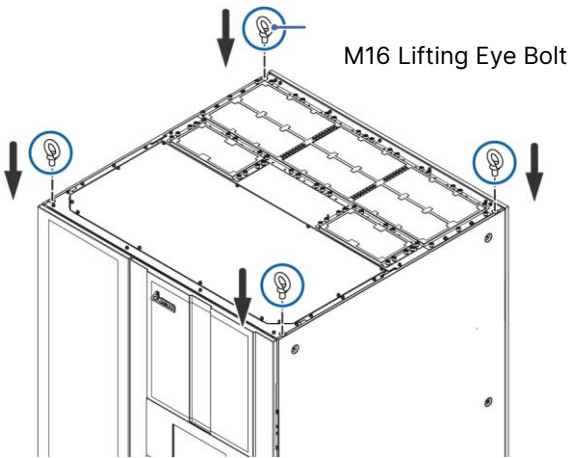

Figure 5-2-1: Installation of M16 Lifting Eye Bolts

Please note that the angle of the lifting straps must be greater than 45° and the swing angle during the lifting process must be less than 15° . Please refer to the figure below.

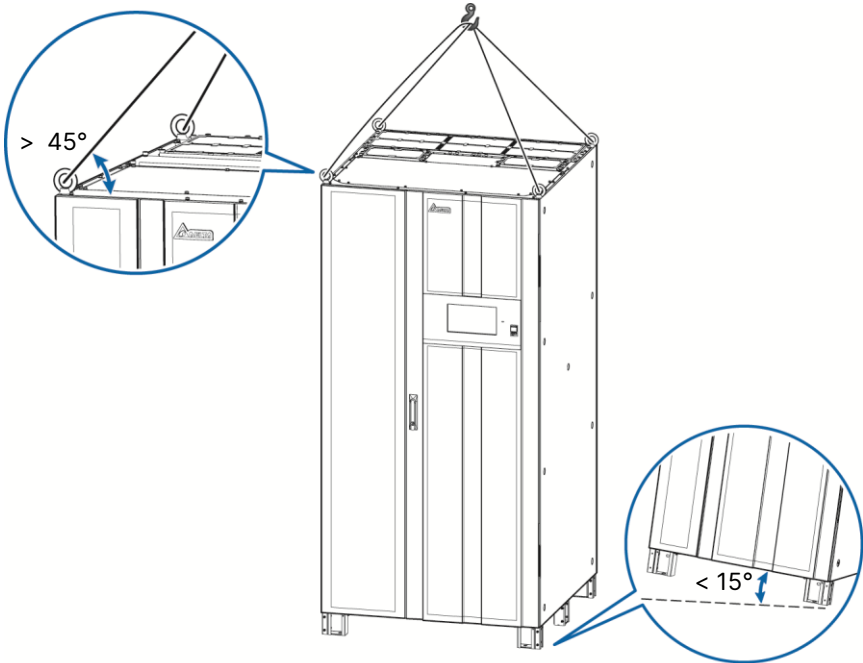

Figure 5-2-2: Lifting Strap Angle and Swing Angle

Step 2

- For installation not against the wall, fix the six stands at the bottom of the UPS on the ground to avoid UPS movement. Each stand requires a M12 expansion bolt (provided by qualified service personnel).

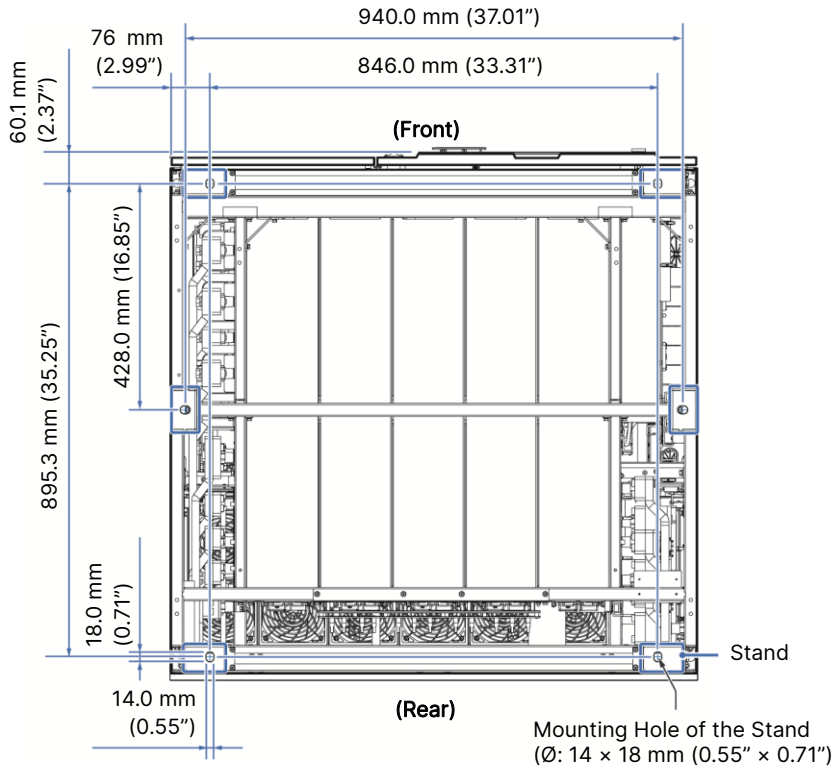

Figure 5-3: Cabinet Floor Fixing Points

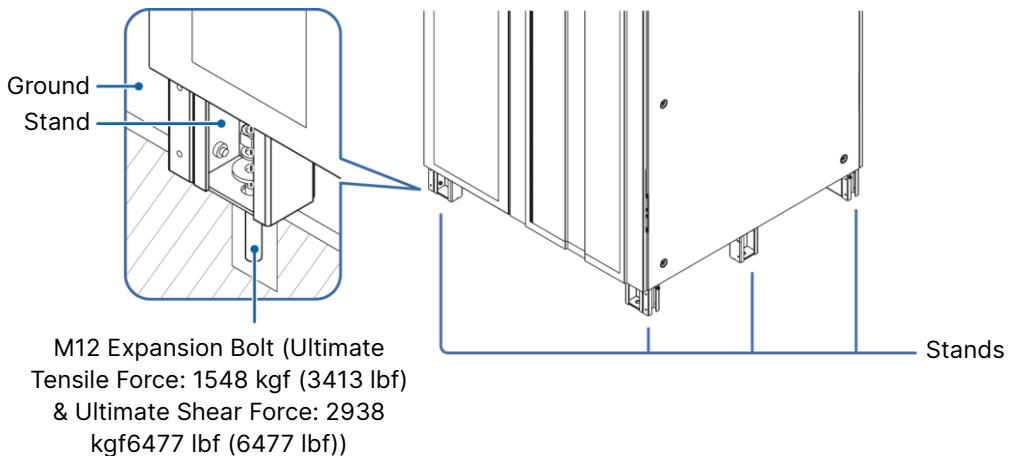

Figure 5-4: Fix the Stands on the Ground



WARNING:

If you don't fix the UPS's stands on the ground, the UPS might topple over. For safety concerns, please fix the UPS's stands on the ground firmly.

- For installation against the wall, please follow the procedures below.

1 → Remove the four M5 screws from the top of the cabinet.

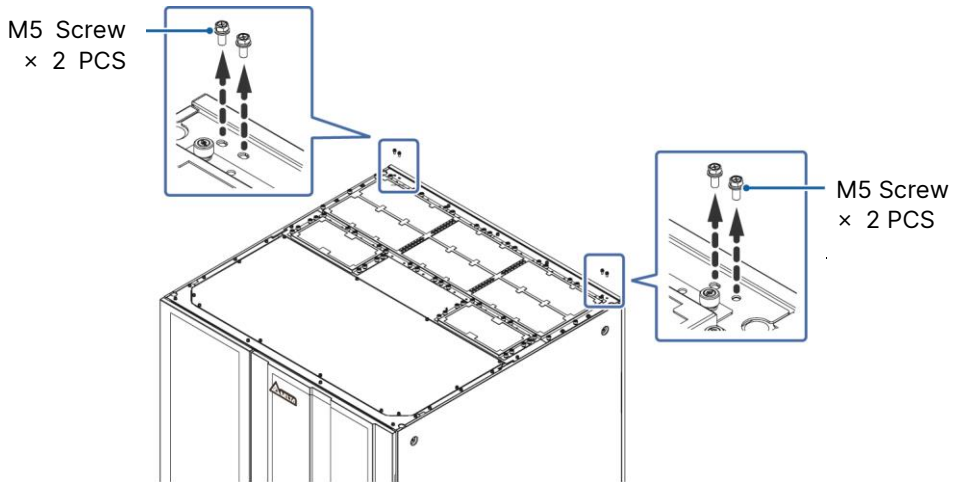

Figure 5-5: Remove the Four M5 Screws from the Top of the Cabinet

- 2 → Use the four M5 screws that you just removed to install the provided seismic kit (including two wall brackets) on the top of the cabinet. The tightening torque for M5 screws should be 35 ± 2 kgf-cm (30.38 ± 1.7 lb-in).

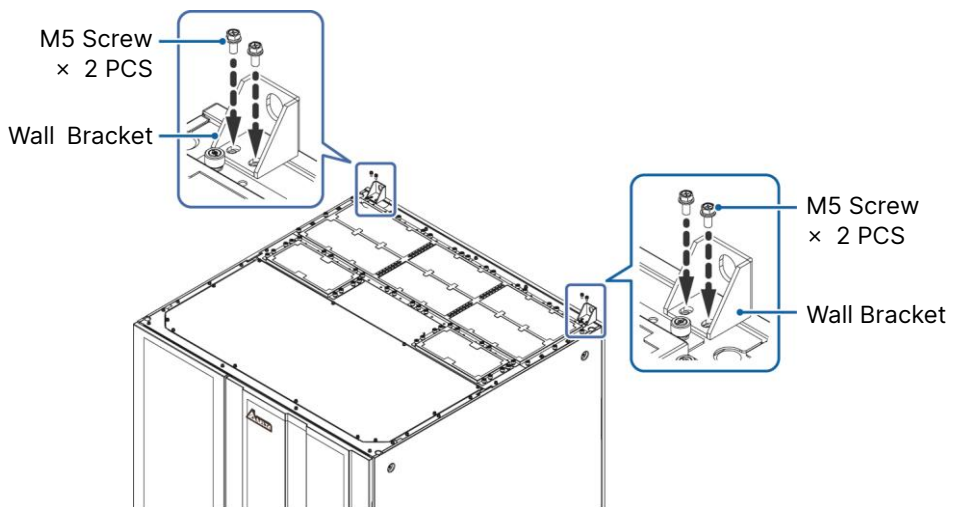

Figure 5-6: Install the Seismic Kit on the Top of the Cabinet

- 3 → Each wall bracket requires a M12 expansion bolt (provided by qualified service personnel) to fix the UPS against the wall.

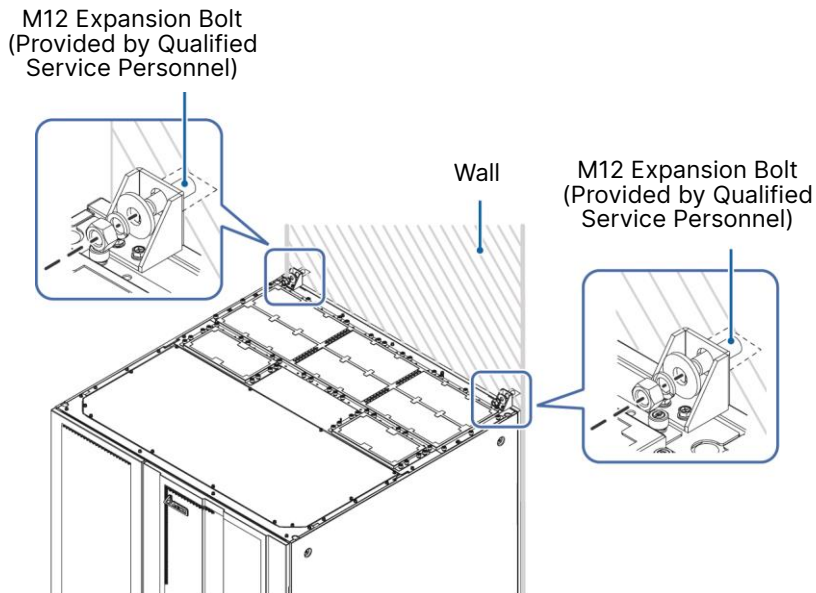

Figure 5-7: Fix the UPS against the Wall

- 4 → Fix the two stands at the front bottom of the UPS on the ground. Each stand requires a M12 expansion bolt (provided by qualified service personnel). Please refer to *Figure 5-3* and *Figure 5-4*.

Step 3

It is suggested that you install the external maintenance bypass cabinet (user-supplied, handled and configured by Delta service personnel) next to the UPS or align it with the UPS for convenient operation.

Step 4

Follow the instructions in *4.3 Cable Routing for the Communication Interfaces* and *5.4 Wiring* to perform wiring between the UPS system cabinet and the external maintenance bypass cabinet. When connecting the external battery cabinet(s), please refer to *5.5 External Battery Cabinet Connection Warnings* to perform external battery cabinet wiring. After routing the cables and verifying cable connections, seal or cover the gaps between the cables and the cabinet(s) to avoid foreign materials falling into the UPS.

Step 5

Follow *5.7 Power Module (Optional)* to install the power modules.

Step 6

After completing the above steps, please reinstall the removed panels and close the front doors if necessary. After that, follow **5.8 Installation of Rodent Shields** to install the rodent shields.

5.4 Wiring

5.4.1 Pre-wiring Warnings



NOTE:

1. Before wiring, please ensure that you have followed **5.3 UPS Installation** to fix the UPS in the designated installation area firmly.
 2. Before wiring, please read **5.4 Wiring** thoroughly.
 3. Only authorized Delta engineers or service personnel can perform installation, wiring, panel & cover removal, maintenance and operation. If you want to execute any action mentioned above by yourself, the action must be under the supervision of authorized Delta engineers or service personnel.
 4. The UPS must be connected with an external maintenance bypass cabinet (user-supplied, handled and configured by Delta service personnel). For information regarding the external maintenance bypass cabinet, please refer to **1.2 Connection Warnings**.
 5. During wiring procedures, please protect the UPS from foreign materials falling into the cabinet(s).
- Before wiring or making any electrical connection, make sure that the power supplied to the input and output of the UPS is completely cut off.
 - Check if the size, diameter, phase and polarity are correct for each cable connecting to the UPS, external battery cabinet(s) and external maintenance bypass cabinet. Please refer to **Table 5-2**.



NOTE:

Table 5-2 is based on (1) default input & output voltage 220V/ 380V, (2) default battery Q'ty: 40 PCS and (3) default charge current per power module: 10A. For other conditions different from **Table 5-2**, please contact Delta service personnel for relevant values.

Table 5-2: Specifications of Input/ Output/ Battery Cables, Switches and External Battery Cabinet's Breaker

UPS Capacity		750kVA/ 750kW	875kVA/ 875kW	1000kVA/ 1000kW	1125kVA/ 1125kW	1250kVA/ 1250kW
Power Module Q'ty		6	7	8	9	10
Input & Bypass	Rated current at 220V with battery charging	1400A	1632A	1866A	2099A	2332A
	Recommended cable size (L1/ L2/ L3/N)	150 mm ² × 5 PCS (300 kcmil × 5 PCS)	150 mm ² × 6 PCS (300 kcmil × 6 PCS)	150 mm ² × 7 PCS (300 kcmil × 7 PCS)	150 mm ² × 8 PCS (300 kcmil × 8 PCS)	150 mm ² × 8 PCS (300 kcmil × 8 PCS)
	Maximum cable size (L1/ L2/ L3/N)	185 mm ² × 5 PCS (400 kcmil × 5 PCS)	185 mm ² × 6 PCS (400 kcmil × 6 PCS)	185 mm ² × 7 PCS (400 kcmil × 7 PCS)	185 mm ² × 8 PCS (400 kcmil × 8 PCS)	185 mm ² × 8 PCS (400 kcmil × 8 PCS)
	Maximum cable lug width	40 mm (1.57")	40 mm (1.57")	40 mm (1.57")	40 mm (1.57")	40 mm (1.57")
	Screw size	M12 (L45)	M12 (L45)	M12 (L45)	M12 (L45)	M12 (L45)
	Terminal type*1	TCL150-2A, TLAPH180-2A12				
Output	Rated current at 220V	1137A	1326A	1516A	1705A	1894A
	Recommended cable size (L1/ L2/ L3/N)	150 mm ² × 4 PCS (300 kcmil × 4 PCS)	150 mm ² × 5 PCS (300 kcmil × 5 PCS)	150 mm ² × 6 PCS (300 kcmil × 6 PCS)	150 mm ² × 6 PCS (300 kcmil × 6 PCS)	150 mm ² × 7 PCS (300 kcmil × 7 PCS)
	Maximum cable size (L1/ L2/ L3/N)	185 mm ² × 4 PCS (400 kcmil × 4 PCS)	185 mm ² × 5 PCS (400 kcmil × 5 PCS)	185 mm ² × 6 PCS (400 kcmil × 6 PCS)	185 mm ² × 6 PCS (400 kcmil × 6 PCS)	185 mm ² × 7 PCS (400 kcmil × 7 PCS)
	Maximum cable lug width	40 mm (1.57")	40 mm (1.57")	40 mm (1.57")	40 mm (1.57")	40 mm (1.57")

UPS Capacity		750kVA/ 750kW	875kVA/ 875kW	1000kVA/ 1000kW	1125kVA/ 1125kW	1250kVA/ 1250kW
Output (continued)	Screw size	M12 (L45)	M12 (L45)	M12 (L45)	M12 (L45)	M12 (L45)
	Terminal type*1	TCL150-2A, TLAPH180-2A12				
Battery	Nominal discharge current (condition: 2V per cell)	1645A	1919A	2193A	2467A	2741A
	Recommended cable size (+/-)	240 mm ² × 5 PCS (500 kcmil × 5 PCS)	240 mm ² × 6 PCS (500 kcmil × 6 PCS)	240 mm ² × 6 PCS (500 kcmil × 6 PCS)	240 mm ² × 7 PCS (500 kcmil × 7 PCS)	240 mm ² × 8 PCS (500 kcmil × 8 PCS)
	Maximum cable size (+/-)	240 mm ² × 5 PCS (500 kcmil × 5 PCS)	240 mm ² × 6 PCS (500 kcmil × 6 PCS)	240 mm ² × 6 PCS (500 kcmil × 6 PCS)	240 mm ² × 7 PCS (500 kcmil × 7 PCS)	240 mm ² × 8 PCS (500 kcmil × 8 PCS)
	Maximum cable lug width	45.5 mm (1.79")	45.5 mm (1.79")	45.5 mm (1.79")	45.5 mm (1.79")	45.5 mm (1.79")
Battery	Screw size	M12 (L60)	M12 (L60)	M12 (L60)	M12 (L60)	M12 (L60)
	Terminal type*1	TLAPH250-2A12				
Tightening Torque		M12 = 500 ± 20 kgf-cm (434 ± 8.7 lb-in)				
External Maintenance Bypass Cabinet's Input Switch (Q1)		3200A	3200A	3200A	3200A	3200A
External Maintenance Bypass Cabinet's Bypass Switch (Q2)		3200A	3200A	3200A	3200A	3200A
External Maintenance Bypass Cabinet's Manual Bypass Switch (Q3)		3200A	3200A	3200A	3200A	3200A

UPS Capacity	750kVA/ 750kW	875kVA/ 875kW	1000kVA/ 1000kW	1125kVA/ 1125kW	1250kVA/ 1250kW
External Maintenance Bypass Cabinet's Output Switch (Q4)	3200A	3200A	3200A	3200A	3200A
External Battery Cabinet's Breaker (Q5)	4000A	4000A	4000A	4000A	4000A

**NOTE:**

1. Please follow local regulations to install proper conduits and bushings for cable protection.
 2. Please refer to national and local electrical codes for acceptable protective devices and cable sizes.
 3. According to the *Table B.52.3* and *Table B.52.5* listed in the IEC 60364-5-52 standard, the cables sizes listed in *Table 5-2* mentioned in this user manual meet the following minimum requirements:
 - Use of 90°C (194°F) copper wires.
 - The selection of cable sizes is based on the ambient temperature of 30°C (86°F). If the ambient temperature exceeds 30°C (86°F), please refer to the IEC standard to correct coefficient to select cable sizes with higher specifications.
 4. *¹ The suggested manufacturer is K. S. Terminals INC. You may use equivalent terminals provided by other manufacturers.
- If there is a floating voltage between the input power's neutral (N) and the PE (protective earth) (⊕), and you require that the VNG of the UPS should be zero, Delta suggests that you install an isolation transformer in front of the input side of the UPS, and connect the isolation transformer's secondary neutral (N) to the PE (protective earth) (⊕) at the proximal end of the isolation transformer.
 - The (main/ bypass) AC source must be a three-phase four-wire system and meets the specifications specified on the UPS rating label. Make sure that the connection is in positive phase sequence.
 - Check the battery polarity when connecting the external battery cabinet(s) to the UPS. Do not connect the battery polarity in reverse. For relevant information, please refer to *5.5 External Battery Cabinet Connection Warnings*.
 - The UPS's PE terminal (⊕) must be grounded. Please use ring-type terminals when wiring.



WARNING:

1. Wrong wiring will cause damage to the UPS and electric shock.
2. If the UPS is not grounded, the power boards and components might be damaged after the UPS is powered on.

5.4.2 Single Input and Dual Input Modification



WARNING:

Only authorized Delta engineers or service personnel can modify single input and dual input setup.

The UPS default setting is single input. If you want to modify it into dual input, please follow the steps below.

Step 1

① Open the UPS's two front doors and ② unscrew the eleven M5 screws to remove the wiring terminal cover. Now, you will see the AC Input terminals (L1/ L2/ L3) and Bypass Input terminals (L1/ L2/ L3).

M5 Screw × 11 PCS &
Wiring Terminal Cover

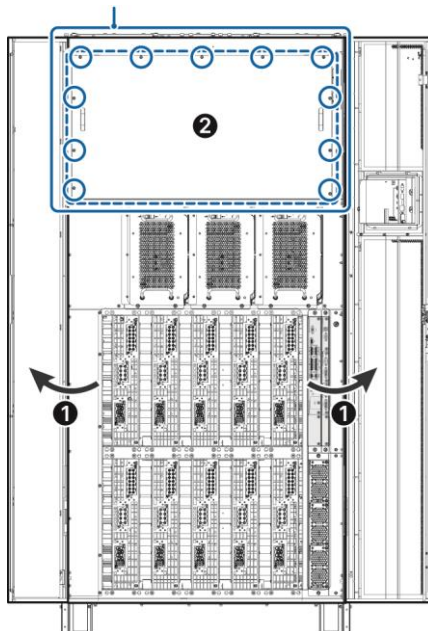

Figure 5-8: Open the Front Doors and Remove the Wiring Terminal Cover

Step 2

Remove the twelve M10 nuts and six cooper bars connected between the AC Input terminals (L1/ L2/ L3) and Bypass Input terminals (L1/ L2/ L3) shown in the figure below.

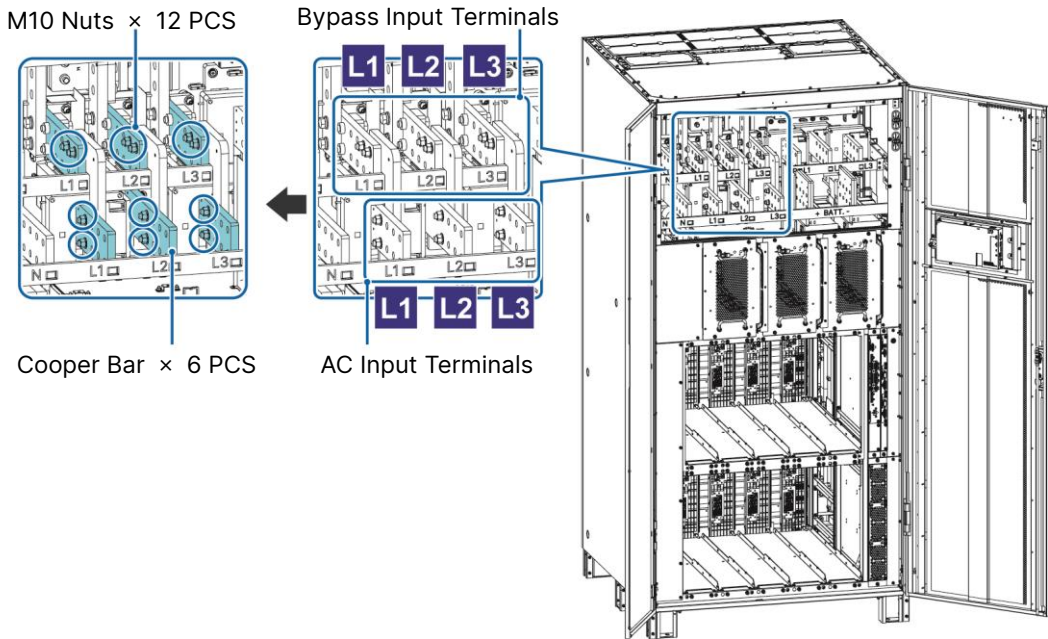

Figure 5-9: Remove the Twelve M10 Nuts and Six Cooper Bars Connected between the AC Input Terminals (L1/ L2/ L3) and Bypass Input Terminals (L1/ L2/ L3)

**NOTE:**



Please keep the removed screws and cooper bars properly for future use. If you want to modify the UPS from dual input into single input, please use the removed twelve M12 screws and six cooper bars to connect the AC Input terminals (L1/ L2/ L3) and Bypass Input terminals (L1/ L2/ L3).

5.4.3 Single Unit Wiring**NOTE:**

Before wiring, please read **5.4 Wiring** thoroughly and make sure that relevant conditions have been met.

Refer to **Table 5-3** for information about the wiring terminals, switches and wiring. For the wiring diagrams and instructions, please refer to the following sections.

Table 5-3: UPS's Wiring Terminals & Wiring Information



No.	Item*1	Function
1	AC Input Terminals (L1/ L2/ L3/ N)	<ul style="list-style-type: none"> • Single Input: Connect the terminals to the external maintenance bypass cabinet's input switch (Q1). • Dual Input: Connect the terminals to the external maintenance bypass cabinet's input switch (Q1).
2	Bypass Input Terminals (L1/ L2/ L3/ N)	<ul style="list-style-type: none"> • Single Input: There is no need to connect the Bypass Input Terminals. • Dual Input: Connect the terminals to the external maintenance bypass cabinet's bypass switch (Q2).
3	UPS Output Terminals (L1/ L2/ L3/ N)	Connect the terminals to the external maintenance bypass cabinet's output switch (Q4).
4	Battery Input Terminals (+/ -)	Connect the terminals to the external battery cabinet(s). Please contact Delta service personnel for battery configurations.
5	 PE (protective earth) Terminal	Connect the terminal to the external maintenance bypass cabinet's GND terminal () and the external battery cabinet's PE terminal ( .



NOTE:

*1 The terminals listed in the above 'Item' column are all located at the front of the UPS with two front doors open and wiring terminal cover removal. Please refer to *Figure 2-5 ~ Figure 2-7*.

Table 5-4: External Maintenance Bypass Cabinet's Switches & Wiring Information

No.	Item* ¹	Function
1	Input Switch (Q1) including L1/ L2/ L3 terminals	Connect the switch to the main AC source.
2	Bypass Switch (Q2) including L1/ L2/ L3 terminals (only for dual input application)	Connect the switch to the bypass AC source.
3	Manual Bypass Switch (Q3) including L1/ L2/ L3 terminals	<ul style="list-style-type: none"> • Single Input: Connect the switch to the main AC source. • Dual Input: Connect the switch to the bypass AC source.
4	Output Switch (Q4) including L1/ L2/ L3 terminals	Connect the switch to the critical loads.
5	 PE (protective earth) Terminal	It is protective earthing for protection against electrical shock in case of fault* ² . The terminal must be connected to the main earth.
6	 GND (ground) Terminals	The terminals are used to ground the devices, which are associated with UPS operation.

**NOTE:**

1. *¹ All switches and terminals listed in the above '**Item**' column must be installed in the external maintenance bypass cabinet (user-supplied, handled and configured by Delta service personnel). Refer to **1.2 Connection Warnings** for relevant information.
2. *² The PE (protective earth) connection ensures that all exposed conductive surfaces are at the same electric potential as the Earth to avoid the risk of electrical shock due to leakage current or an insulation fault.

5.4.3.1 Single Input (Single Unit)

When there is only one AC power source, single unit wiring procedures are as follows.

Step 1

Make sure that the external maintenance bypass cabinet's Input Switch (Q1), Bypass Switch (Q2), Manual Bypass Switch (Q3) and the Output Switch (Q4) are in the **OFF** position.

Step 2

Make sure that each external battery cabinet's breaker (Q5) is in the **OFF** position.

Step 3

Follow *Table 5-2* to select proper input, output and battery cables.

Step 4

The UPS only allows cable routing from the top. Please leave adequate space above the UPS.

Step 5

Open the ❶ UPS's left and right front doors. Remove the ❷ top cover and ❸ wiring terminal cover.

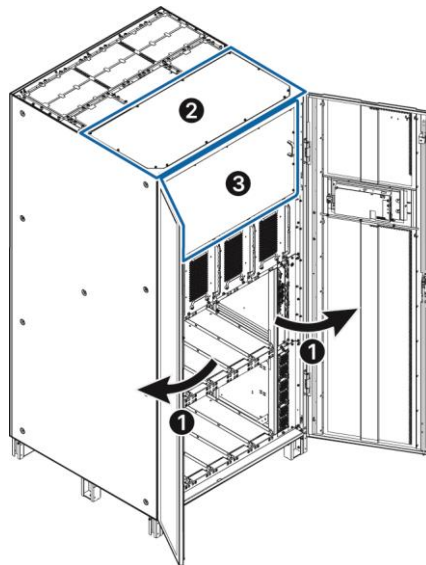

Figure 5-10: Open the Left & Right Front Doors and Remove the Top Cover & Wiring Terminal Cover

Step 6

Follow **1.1 Installation Warnings** and on-site requirements to drill holes on the top cover and install conduits (user-supplied) on it. The opening size on the top cover should be defined by users. After completion, re-install the top cover. This helps to prevent foreign objects from falling into the cabinet.

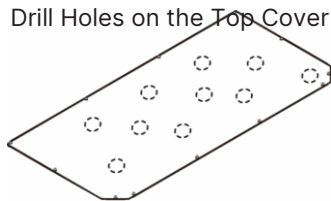

Figure 5-11: Drill Holes, Install Conduits (User-supplied) and Reinstall the Top Cover

Step 7

Route the cables from the user-supplied conduits and connect the cables to the wiring terminals shown in **Figure 2-5 ~ Figure 2-7**.

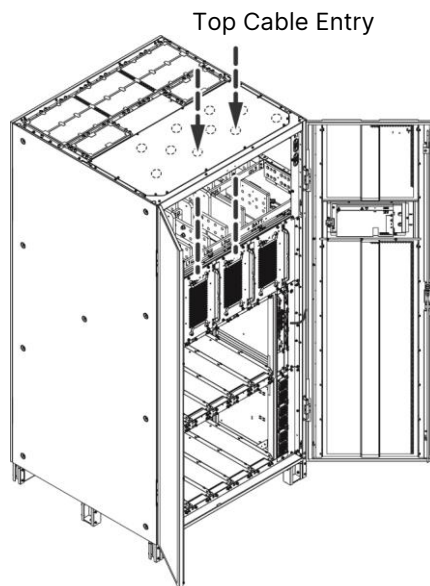

Figure 5-12: Top Cable Entry for the Wiring Terminals

Step 8

Install the provided insulating plate between the AC Input & Battery Input terminals.

- 1 Please insert the insulating plate into the two rivets fixed on the cabinet. After insertion, 2 pull the insulating plate outward to fix it firmly.

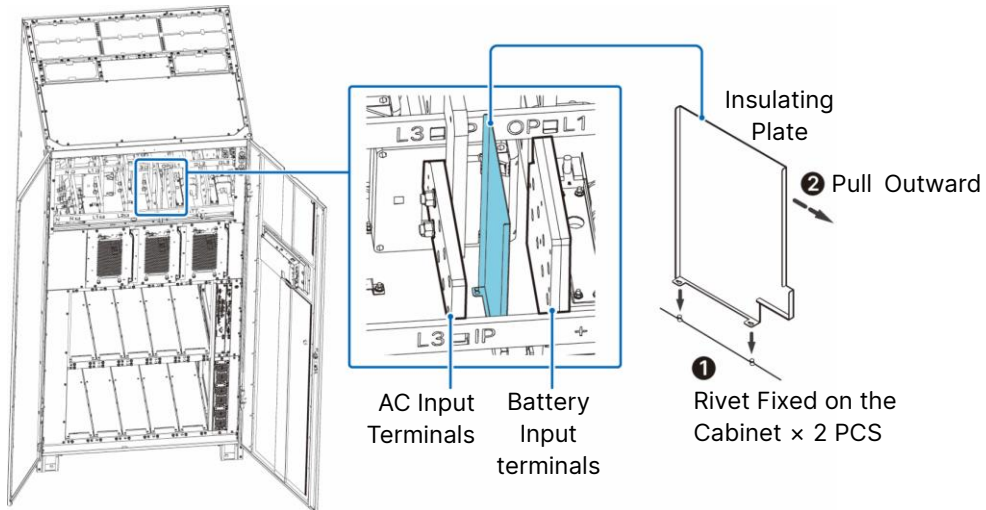

Figure 5-13: Install the Provided Insulating Plate

Step 9

Connect the cables of the main AC source, output and external battery cabinet(s) to the UPS and the external maintenance bypass cabinet. Please refer to **Table 5-3, Table 5-4, 5.5 External Battery Cabinet Connection Warnings** and the following diagram to perform wiring.

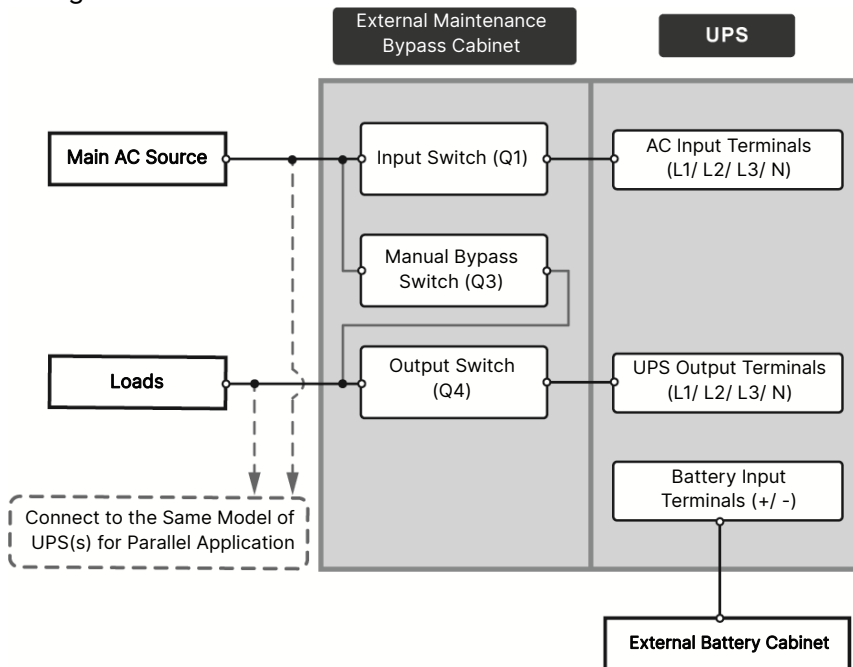

Figure 5-14: Single Unit Single Input Wiring Diagram

Step 10

Follow the table below to select proper Protective Earth (PE) cables to ground the UPS, external battery cabinet(s) and connected critical loads. The table is in accordance with IEC 60364-5-54 (Article 543 & Table 54.2). The grounding diagram below is for reference.

UPS Capacity	750kVA/ 750kW	875kVA/ 875kW	1000kVA/ 1000kW	1125kVA/ 1125kW	1250kVA/ 1250kW
Power Module Q'ty	6	7	8	9	10
Suggested PE Cable Size	240 mm ² × 3 PCS (500 kcmil × 3 PCS)	240 mm ² × 3 PCS (500 kcmil × 3 PCS)	240 mm ² × 3 PCS (500 kcmil × 3 PCS)	240 mm ² × 4 PCS (500 kcmil × 4 PCS)	240 mm ² × 4 PCS (500 kcmil × 4 PCS)
Terminal Type* ¹	TLAPH250-2A12				
Maximum Cable Lug Width	45.5 mm (1.79")				
Screw Size	M12 (L45)				
Tightening Torque	M12 = 500 ± 20 kgf-cm (434 ± 8.7 lb-in)				

**NOTE:**

*¹ The suggested manufacturer is K.S. TERMINAL INC. You may use equivalent terminals provided by other manufacturers.

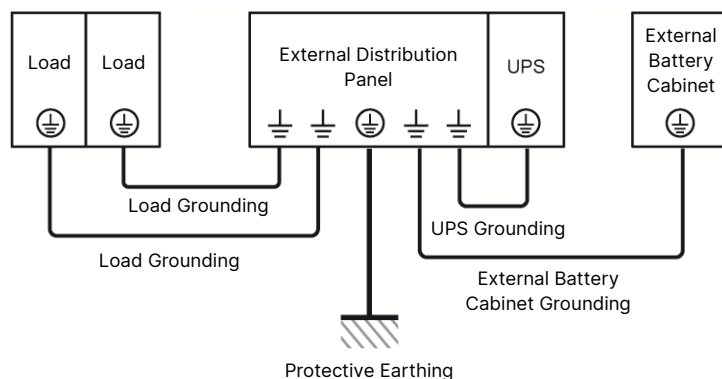

Figure 5-15: Grounding Diagram_ Single Unit

5.4.3.2 Dual Input (Single Unit)

When there are two AC power sources, single unit wiring procedures are as follows.

Step 1

Follow **5.4.2 Single Input and Dual Input Modification** to modify the UPS from single input to dual input.

Step 2

Follow **Step 1 ~ Step 8** mentioned in **5.4.3.1 Single Input (Single Unit)**.

Step 3

Connect the cables of the main AC source, bypass source, output and external battery cabinet(s) to the UPS and the external maintenance bypass cabinet. Please refer to **Table 5-3, Table 5-4, 5.5 External Battery Cabinet Connection Warnings** and the following diagram to perform wiring.

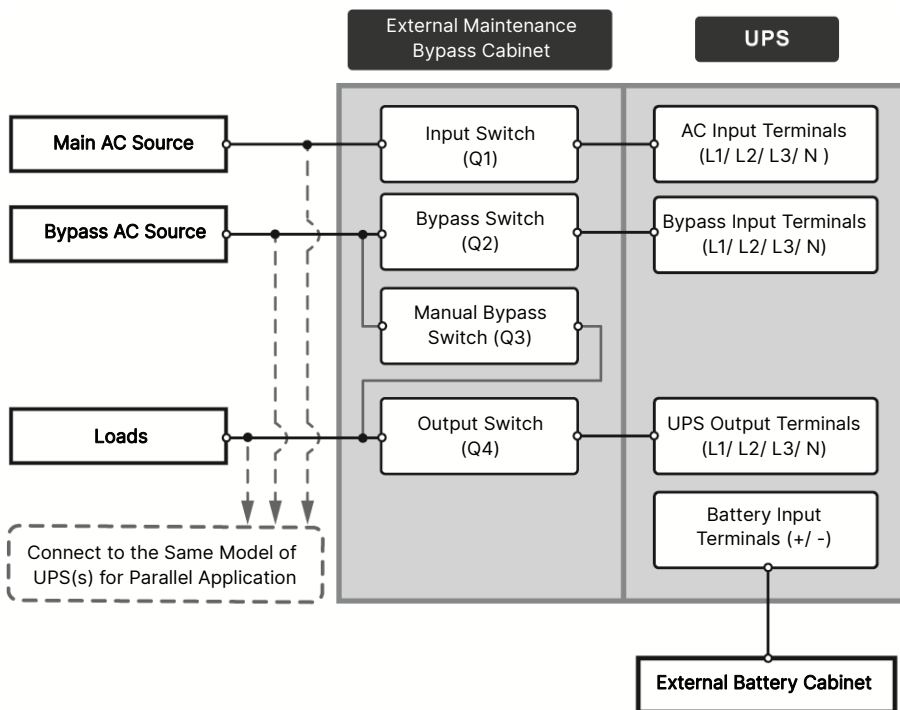

Figure 5-16: Single Unit Dual Input Wiring Diagram

Step 4

Follow **Step 10** mentioned in **5.4.3.1 Single Input (Single Unit)** and refer to **Figure 5-15** to ground the UPS, external battery cabinet(s) and connected critical loads.

5.4.4 Parallel Units Wiring



NOTE:

1. Up to eight UPS units can be paralleled for redundancy and capacity expansion. Only the UPSs with the same capacity, voltage, frequency and version can be paralleled. Please only use the provided parallel cable to parallel the UPS units. Otherwise, parallel functions will fail.
2. When the UPSs are paralleled, the length of each unit's bypass input cables plus output cables must be the same. This ensures that the parallel UPSs can equally share the critical loads in Bypass mode.

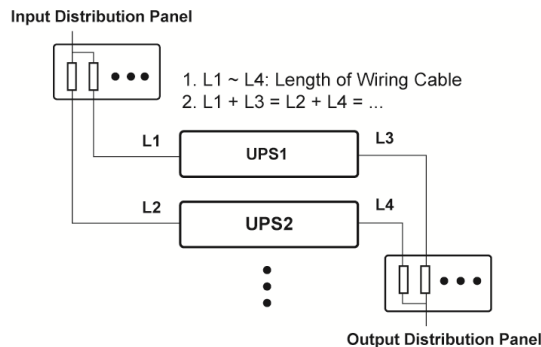

3. Before wiring, please read **5.4 Wiring** thoroughly and make sure that relevant conditions have been met.

Step 1

For single input, follow **Step 1 ~ Step 10** mentioned in **5.4.3.1 Single Input (Single Unit)**. As for the grounding diagram, please refer to **Figure 5-18** rather than **Figure 5-15**.

For dual input, follow **Step 1 ~ Step 4** mentioned in **5.4.3.2 Dual Input (Single Unit)**. As for the grounding diagram, please refer to **Figure 5-18** rather than **Figure 5-15**.

Step 2

Use the provided parallel cables*¹ to connect the parallel ports of the parallel units. Please adopt the Daisy Chain method shown in the figure below. For the parallel port location, refer to **Figure 4-1**. For cable entry, refer to **4.3 Cable Routing for the Communication Interfaces**.



NOTE:

*1 One parallel cable is provided in each UPS's accessory package.

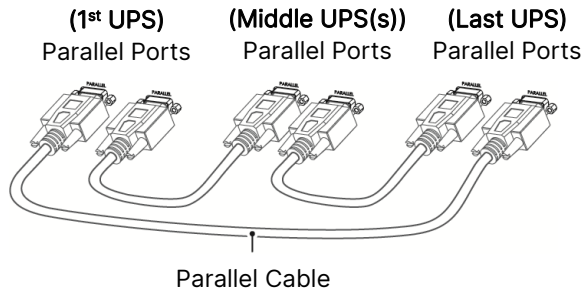

Figure 5-17: Parallel Port Connection_ Daisy Chain Method

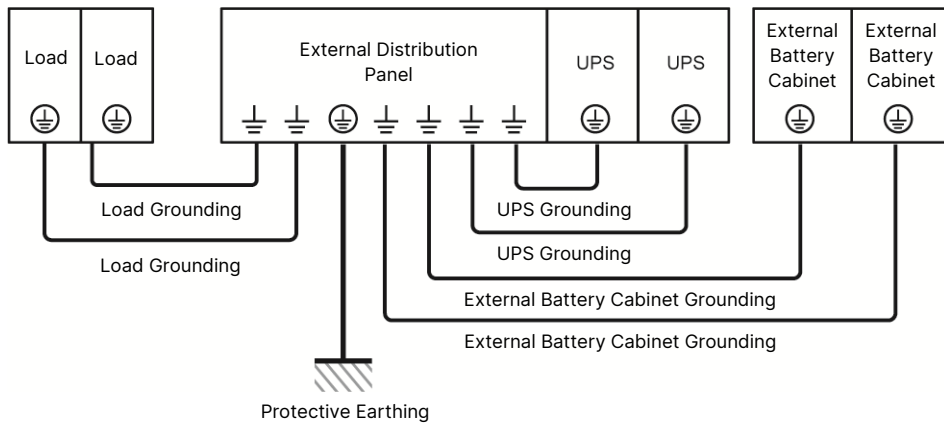

Figure 5-18: Grounding Diagram_ Parallel Units



WARNING:

Before start-up of the parallel units, qualified service personnel must set each UPS's '**Parallel Group ID**' (1 or 2) and '**Parallel ID**' (1 ~ 4) through the LCD. Otherwise, the parallel UPSs cannot be started. Please refer to **7.6.5 Parallel Setting**.

5.5 External Battery Cabinet Connection Warnings



NOTE:

1. The information of the battery parameters in this chapter may not be applicable to the lithium-ion batteries. For relevant information, please refer to the manual of the lithium-ion batteries.
2. Whether you use the lead-acid batteries or the lithium-ion batteries, please contact Delta service personnel for any battery/ battery cabinet's setup and configurations.



WARNING:

1. Before performing battery/ battery cabinet installation, wiring and replacement, please turn off each external battery cabinet's breaker (Q5) to completely disconnect the battery power from the UPS.
2. A battery can present a risk of electric shock and high short-circuit current. Servicing of batteries and battery cabinets must be performed or supervised by qualified service personnel knowledgeable in batteries, battery cabinets and the required precautions. Keep unauthorized personnel away from batteries and battery cabinets.

You should connect the UPS with at least one external battery cabinet to ensure that the connected critical loads are protected when a power failure occurs. You can connect up to eight units of external battery cabinets to the UPS.

- To ensure that the batteries are fully charged, please charge the batteries for at least 8 hours before initial use of the UPS. The charging procedures are as follows.
 1. (A) Connect the UPS to the external maintenance bypass cabinet (user-supplied, handled and configured by Delta service personnel) and external battery cabinet(s), and (B) connect the main AC source and bypass AC source (for dual input application only) to the external maintenance bypass cabinet. Please refer to **5.4 Wiring**.
 2. Follow **6. UPS Operation** to turn on the external maintenance bypass cabinet, UPS and the external battery cabinet(s). After that, the batteries will be charged automatically.



WARNING:

You can connect the critical loads to the external maintenance bypass cabinet only after the batteries are fully charged. This guarantees that the external maintenance bypass cabinet can provide sufficient backup power to the critical loads connected when a power failure occurs.

- To connect the external battery cabinet(s) to the UPS, please refer to **5.4 Wiring** and **Figure 5-19**.

- For the external battery cabinet's grounding information, please refer to *Figure 5-15* and *Figure 5-18*.
- **Battery Parameters**

No.	Item	750kVA/	875kVA/	1000kVA/	1125kVA/	1250kVA/
		750kW	875kW	1000kW	1125kW	1250kW
1	Charge Voltage	Float charge voltage: 544 Vdc (default)				
		Equalized charge voltage: 560 Vdc (default)				
2	Charge Current	Default: 60A				
3	Low Battery Shutdown Voltage	400 ~ 440 Vdc (default: 420 Vdc)				
4	Battery Quantity	12V × 40 PCS (default)				



NOTE:

1. The charge current is adjustable from 1A to the maximum, 1A per step.
 2. If you need to modify the default low battery shutdown setting, please contact your local dealer or service personnel.
 3. Follow on-site requirements to choose 12V × 32 ~ 48 PCS of batteries. Change of the battery quantity will influence the applied specifications. For battery selection, installation and replacement, please contact your local dealer or customer service.
 4. You must set up the '**Battery Rating Voltage**', '**Battery Strings**' and '**Capacity**' on the LCD according to on-site application. Otherwise, the batteries will be over-charged, not fully charged or even seriously damaged.
- Only use the same type of batteries from the same supplier. Never use old, new and different Ah batteries at the same time.
 - The number of batteries must meet the UPS requirements.
 - Do not connect the batteries in reverse.
 - Use a voltage meter to measure whether the total voltage is around 12.5Vdc × the total number of batteries after the batteries are connected in series.
 - The default battery quantity is 40 PCS of 12V batteries connected in series. You should use battery cables to connect the external battery cabinet(s) with the '+' and '-' terminals marked on the UPS.

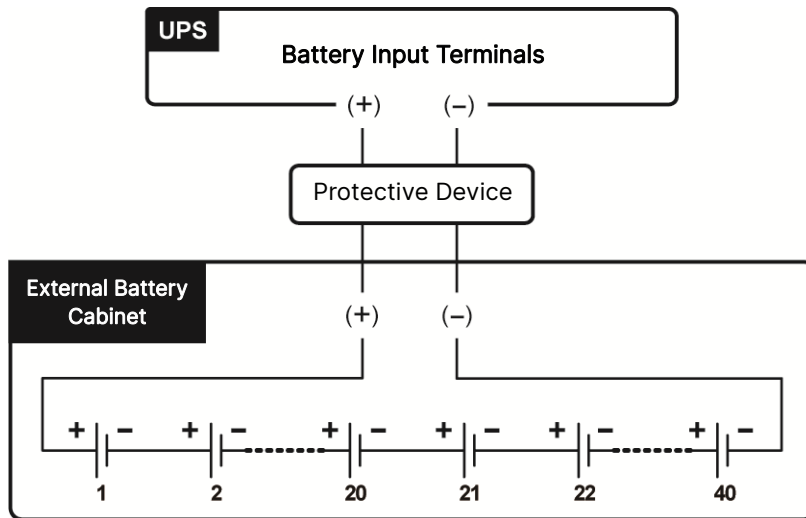

Figure 5-19: External Battery Cabinet Connection

**WARNING:**

The electrolyte leakage of the batteries can lead to serious accidents. For safety's sake, you must insulate the batteries properly (using insulated trays or boxes) from the metal cabinets and racks.

- **Installation of the External Battery Cabinet's Protective Device**

Please follow your UPS's rating to install an appropriate protective device for each external battery cabinet. Please refer to *Table 5-5* and *Figure 5-20~ Figure 5-23*.

Table 5-5: External Battery Cabinet's Protective Device (Default Battery Q'ty: 12 Vdc × 40 PCS)

UPS Capacity	Power Module Q'ty	3-Pole DC Circuit Breaker/ DC Isolated Switch (Voltage Per Pole \geq 600Vdc)	2-Pole DC Circuit Breaker/ DC Isolated Switch (Voltage Per Pole \geq 600Vdc)	DC Fuse (Voltage \geq 690Vdc)
750kVA/ 750kW	6	2500A	2500A	2500A
875kVA/ 875kW	7	3200A	3200A	3200A
1000kVA/ 1000kW	8	3200A	3200A	3200A
1125kVA/ 1125kW	9	3600A	3600A	3600A

UPS Capacity	Power Module Q'ty	3-Pole DC Circuit Breaker/ DC Isolated Switch (Voltage Per Pole \geq 600Vdc)	2-Pole DC Circuit Breaker/ DC Isolated Switch (Voltage Per Pole \geq 600Vdc)	DC Fuse (Voltage \geq 690Vdc)
1250kVA/ 1250kW	10	4000A	4000A	4000A



NOTE:

1. **Table 5-5** is for 12 Vdc \times 40 PCS of batteries (default). If you install a different number of batteries, please contact Delta service personnel for the protective device's current and voltage.
 2. If you need to parallel multiple units of external battery cabinets, please contact Delta service personnel for relevant information.
 3. To extend backup time, you can parallel up to eight units of external battery cabinets to the UPS. Please note that (1) the number of the batteries in each paralleled external battery cabinet and (2) the cable length of each battery string must be the same.
 4. If the battery quantity is lower than 38, the UPS capacity should be de-rated to 80%; otherwise, it will trigger power modules' over temperature protection and the UPS will run in bypass mode.
- When choosing the external battery cabinet's protective device, please take the following factors into consideration: (1) overcurrent between the UPS and battery circuit, (2) short circuit current of the batteries, (3) wire/ cable materials, and (4) local electrical regulations. If you have any questions about the external battery cabinet's protective device, please contact Delta service personnel.
 - The protective device is optional, and its type must be fast-acting DC circuit breaker and/ or fast-acting DC fuse. If you want to buy any of them, please contact Delta service personnel. When choosing the protective device, please follow the instructions below.
 - (1) The protective device's rated current must comply with the current values shown in **Table 5-5**.
 - (2) The specifications of the protective device's short-circuit protection (i.e. the tripping current of the fast-acting DC circuit breaker and/ or the melting current of the fast-acting DC fuse) must be 4 ~ 6 times the values shown in **Table 5-5**. Besides, the response time of the protective device must be less than 20 ms.
 - (3) For the choice of the fast-acting DC fuse mentioned above, the A50QS series from the supplier **Ferraz Shawmut** is suggested. Please contact Delta customer service for relevant information.

- (4) The maximum tripping current of the fast-acting DC circuit breaker and/ or the maximum melting current of the fast-acting DC fuse mentioned above are 6 times as much as the values shown in **Table 5-5**. These maximum values are suggested for general applications only. For the actual maximum values, the maximum short-circuit capacity of the on-site batteries must be taken into consideration. Please contact Delta customer service for relevant information.
- (5) The maximum allowable fault current is 15 kA. Please confirm that the interrupting rating of your chosen protective device is sufficient.

External Battery Cabinet's Protective Device (Option 1)

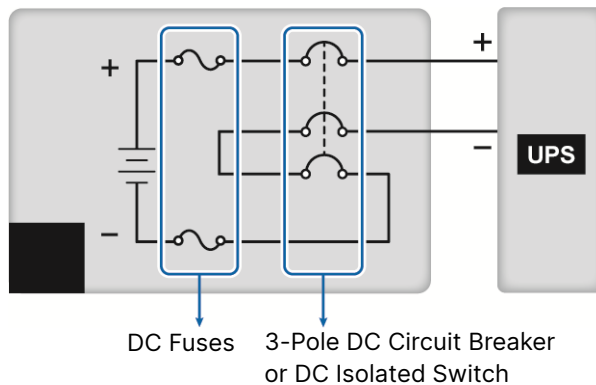

Figure 5-20: Installation of a 3-pole DC Circuit Breaker or DC Isolated Switch Connected in Series with DC Fuses

External Battery Cabinet's Protective Device (Option 2)

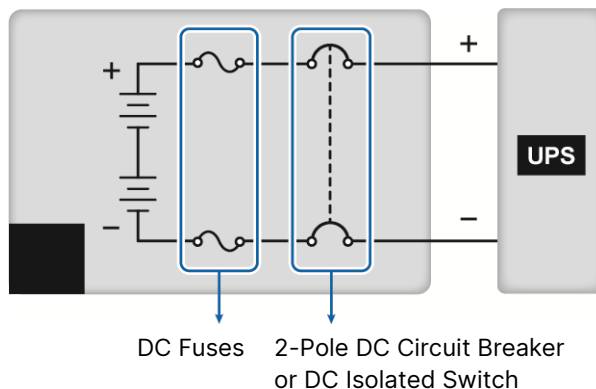

Figure 5-21: Installation of a 2-pole DC Circuit Breaker or DC Isolated Switch Connected in Series with DC Fuses

External Battery Cabinet's Protective Device (Option 3)

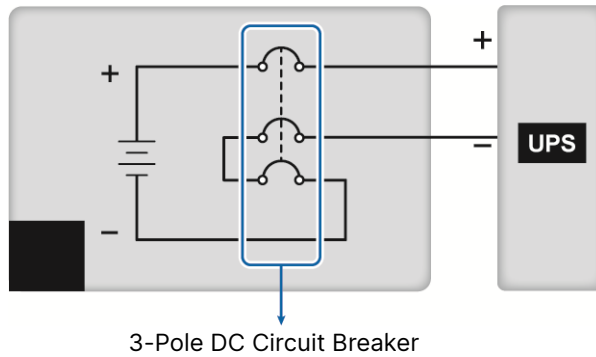

Figure 5-22: Installation of a 3-pole DC Circuit Breaker

External Battery Cabinet's Protective Device (Option 4)

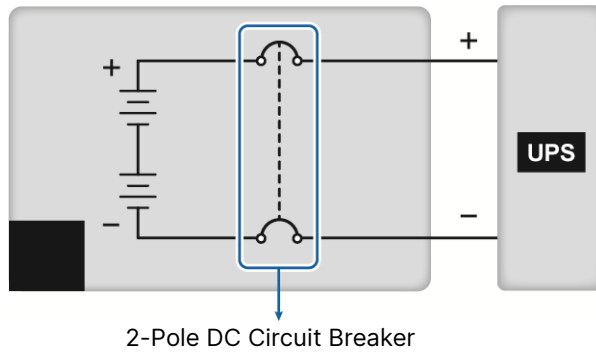

Figure 5-23: Installation of a 2-pole DC Circuit Breaker

- **Common Battery (Only for Parallel UPSs Sharing the Same External Battery Cabinet(s))**

To save on your costs and installation space, the parallel UPSs can share their connected external battery cabinet(s). See *Figure 5-24* for two parallel UPSs sharing one external battery cabinet as an example.



NOTE:

The following 'common battery' information is not applicable to the UPS using lithium-ion batteries. For relevant information, please refer to the user manual of the lithium-ion batteries. Whether you use the lead-acid batteries or the lithium-ion batteries, please contact Delta service personnel for any battery/battery cabinet's setup and configurations.

For common battery application, please install a protective device between each parallel UPS and its connected external battery cabinet(s). You have to use the LCD to set each UPS's '**Float Charge Voltage**' (default: 544V) the same, '**Equalized Charge Voltage**' (default: 560V) the same, '**Battery Strings**' even and '**Charge Current (Max)**' even. Please refer to the examples below and *7. LCD Display & Settings*.

Example I

When (1) two UPSs are paralleled and share one external battery cabinet, (2) lead-acid batteries are used, (3) the battery capacity is 200AH, (4) there are a total of 4 battery strings, and (5) the charge current is 80A, please use the LCD to set each UPS's 'Battery Type' as 'VRLA', 'Capacity' as 200AH, 'Battery Strings' as 2, and 'Charge Current (Max)' as 40A.

Example II

When (1) three UPSs are paralleled and share one external battery cabinet, (2) lead-acid batteries are used, (3) the battery capacity is 300AH, (4) there are a total of 3 battery strings, and (5) the charge current is 90A, please use the LCD to set each UPS's 'Battery Type' as 'VRLA', 'Capacity' as 300AH, 'Battery Strings' as 1, and 'Charge Current (Max)' as 30A.

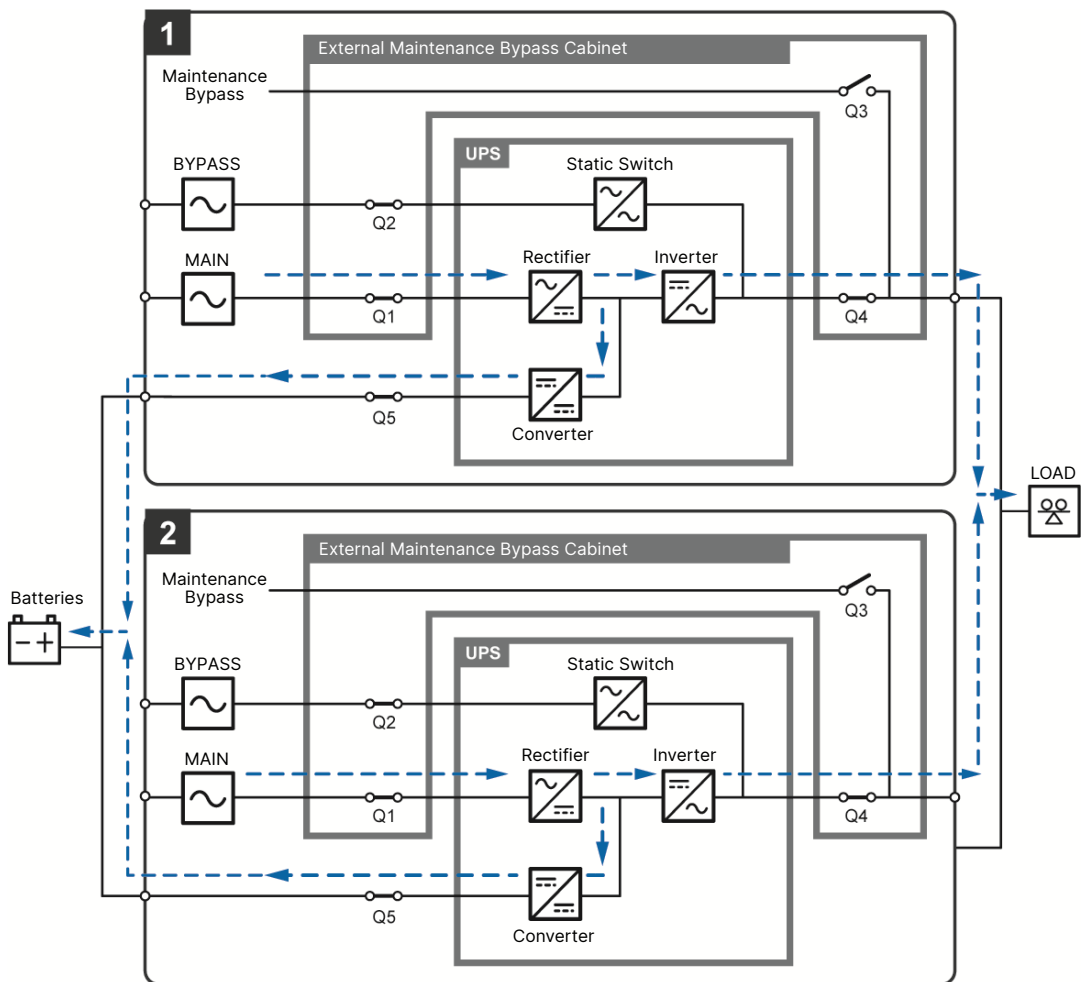

Figure 5-24: Common Battery Diagram

- **External Battery Cabinet Alarm**

When any external battery cabinet connected to the UPS has the following problems, the UPS system will sound an alarm. Please see the table below.

No.	External Battery Cabinet Status	Alarm
1	Battery Abnormal - Reversed	It sounds 0.5 seconds every second.
2	Battery Ground Fault	It sounds 0.5 seconds every second.
3	Battery Over Temperature	It sounds 0.5 seconds every second.
4	Battery Under Temperature	It sounds 0.5 seconds every second.
5	Battery Breaker Off	It sounds 0.5 seconds every 3 seconds.
6	Battery Disconnected (Missing)	It sounds once every second.
7	Battery Over Charged	Long beep.
8	Battery Test Fail	It sounds 0.5 seconds every second.
9	Battery End of Discharge Imminent	It sounds 0.5 seconds every second.
10	Battery End of Discharge	Long beep.
11	Battery Life Time Expired	It sounds 0.5 seconds every 3 seconds.

5.6 STS Module

The STS module has been installed in the UPS by default. Please refer to *Figure 2-4* for its location.

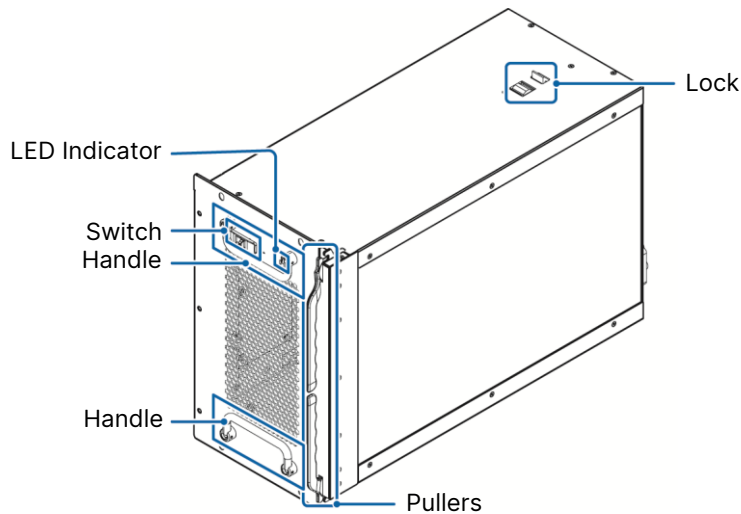

Figure 5-25: STS Module

5.6.1 STS Module Installation



WARNING:

1. Only when (1) the UPS runs in manual bypass mode, (2) the capacitors are completely discharged and (3) the battery power is completely cut off can qualified service personnel perform the following installation procedures.
2. The STS module is heavy (39 kg (85.98 lb)). At least two people are required for handling.

Step 1

Confirm that the STS module's switch is in the lower position () and the pullers are in the open status.

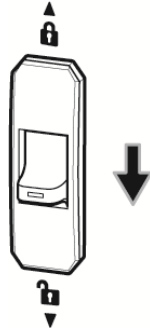

Figure 5-26: Confirm the STS Module's Switch in the Lower Position

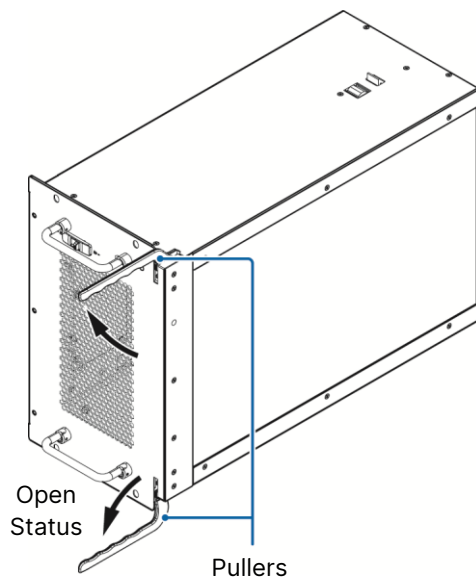

Figure 5-27: Confirm the Pullers in the Open Status

Step 2

Arrange two persons to install the STS module. One person holds one handle and the other holds the other one (1). Two persons work together to lift the STS and insert it into the designated slot (2). Next, one person holds the two pullers (3) and pushes them inwards in order to push the module into the slot. Once the module snaps into place, the pullers will be in the closed status.

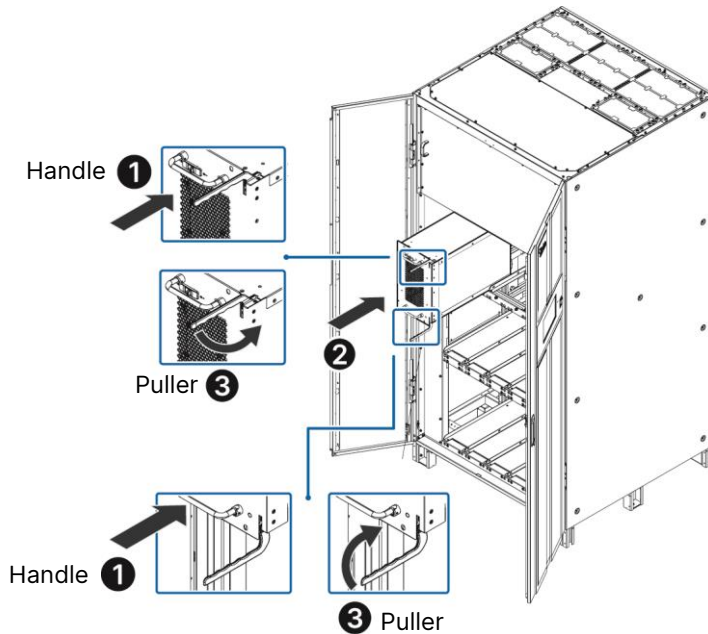

Figure 5-28: Insert the STS Module into the UPS Cabinet

Step 3

Use the four M6 screws and three M4 screws removed during the STS module removal process to fix the STS module and the metal windshield on the UPS cabinet respectively. Whenever you install an STS module, a metal windshield shall be installed.

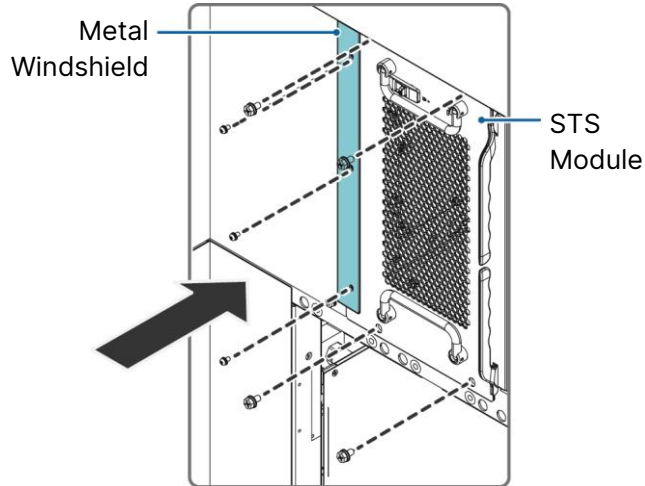



Figure 5-29: Fix the STS Module & Metal Windshield on the UPS Cabinet

Step 4

Turn the STS module's switch to the upper position ().

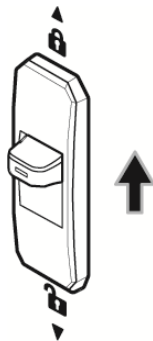

Figure 5-30: Turn the STS Module's Switch to the Upper Position

5.6.2 STS Module Removal



WARNING:

1. Only when (1) the UPS runs in manual bypass mode, (2) the capacitors are completely discharged and (3) the battery power is completely cut off can qualified service personnel perform the following removal procedures.
2. The STS module is heavy (39 kg (85.98 lb)). At least two people are required for handling.

Step 1

Turn the STS module's switch to the lower position () and wait until the STS module's LED indicator becomes off.

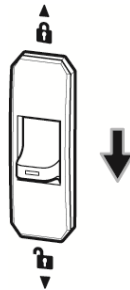

Figure 5-31: Turn the STS Module's Switch to the Lower Position

Step 2

Remove the four M6 screws, three M4 screws and the metal windshield from the STS module.

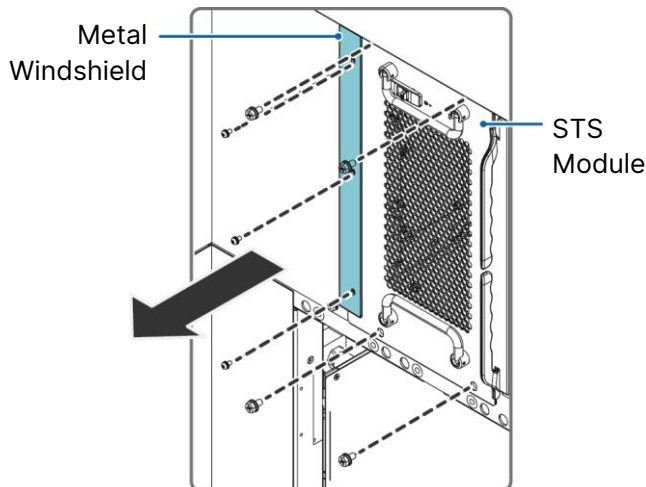

Figure 5-32: Remove the Four M6 Screws, Three M4 Screws & Metal Windshield from the STS Module

Step 3

Arrange two persons to remove the STS module. One person holds the STS module's two pullers and opens them outward (1); at this moment, the STS module would come out from the slot a little bit (2). Next, one person holds one handle and the other holds the other one (3) and two persons work together to pull out the STS module from the slot. When the STS module cannot be pulled out any more, press the lock (4) on the top of the STS module. After that, two persons can continuously pull out the module from the UPS cabinet.

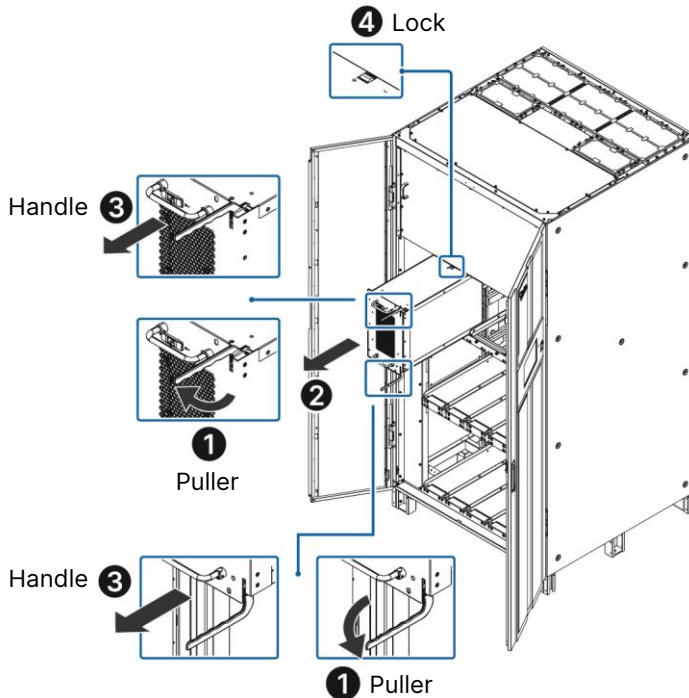

Figure 5-33: Remove the STS Module from the UPS Cabinet

5.6.3 STS Module's LED Indicator

The STS module's LED indicator shows its operation status. Please refer to the following table.

LED Indicator	Description
OFF	The STS module is OFF .
ON (yellow)	The STS module is working in Bypass mode or ECO mode.
Flashing (yellow)_ on for 0.3 seconds and off for 3 seconds	The STS module is abnormal.

**NOTE:**

Under STS module running conditions, if you turn the STS module's switch to the lower position (↓), the STS module will shut down its output and its LED indicator will be off.

5.7 Power Module (Optional)

The power module is optional and hot-swappable; each capacity is 125kVA/ 125kW. Please install an appropriate number of power modules according to UPS capacity.

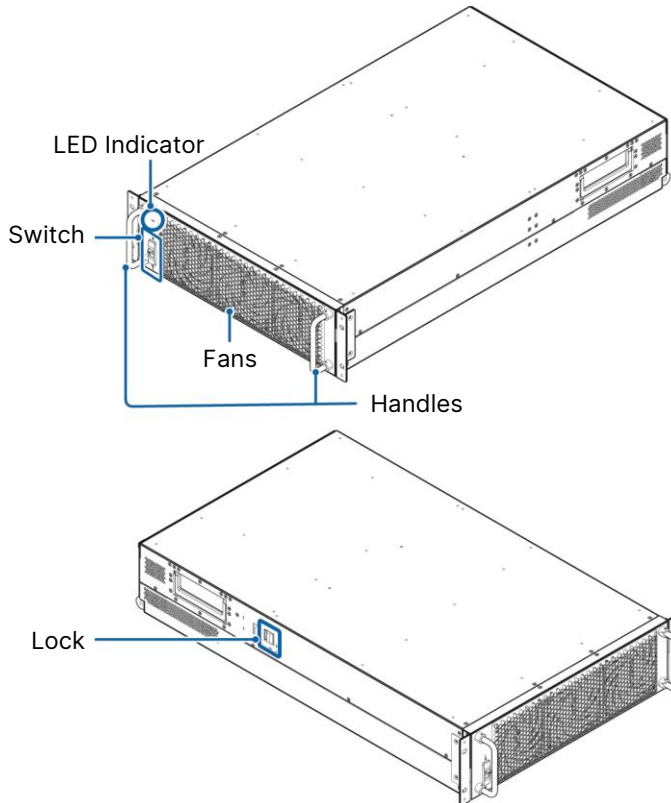
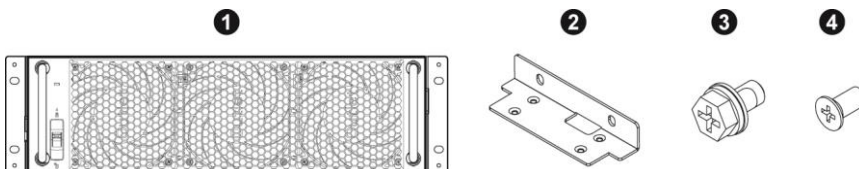

Figure 5-34: Power Module (Optional)

Please see the table below for the power module's packing list.



No.	Item	Q'ty
①	Power Module	1 PC
②	Ear Bracket	2 PCS

No.	Item	Q'ty
3	M6 Screw	4 PCS
4	M4 Screw	8 PCS

5.7.1 Power Module Installation



WARNING:

1. Only when (1) the UPS runs in manual bypass mode, (2) the capacitors are completely discharged and (3) the battery power is completely cut off can qualified service personnel perform the following installation procedures.
2. The power module is heavy (60 kg (132.28 lb)). At least three people are required for handling.
3. Please follow your UPS capacity and the table below to install the correct number of power modules.

DPH Gen3 Series					
UPS Capacity	750kVA/ 750kW	875kVA/ 875kW	1000kVA/ 1000kW	1125kVA/ 1125kW	1250kVA/ 1250kW
Power Module Q'ty	6	7	8	9	10

4. For installation location, please follow the sequential numbers marked on the figure below to install the power modules into the correct power module slots in order.

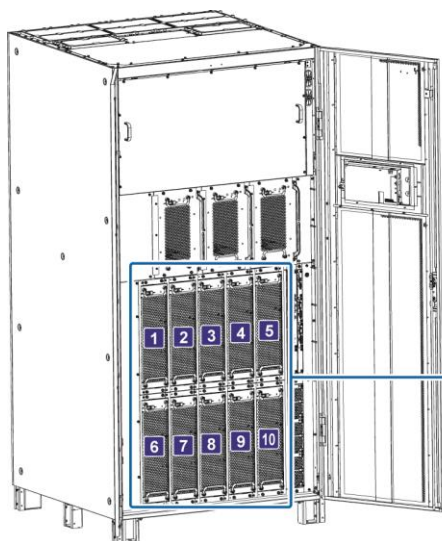

Follow the Sequential Numbers Shown on the Figure to Install the Power Modules into the Correct Power Module Slots.

Step 1

Confirm that the power module's switch is in the lower position ().

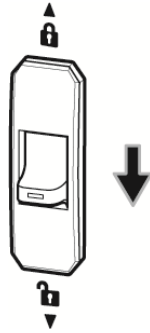

Figure 5-35: Confirm the Power Module's Switch in the Lower Position

Step 2

Use the eight M4 screws to fix the two ear brackets on the two sides of the power module.

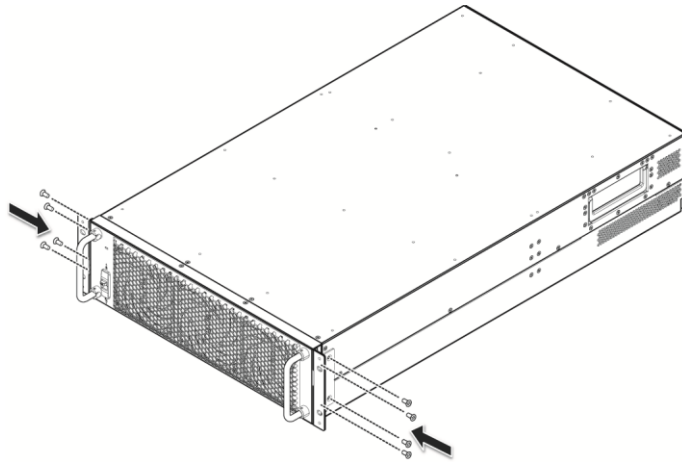

Figure 5-36: Install the Two Ear Brackets

Step 3

Insert the power module into the power module slot until it snaps into place.

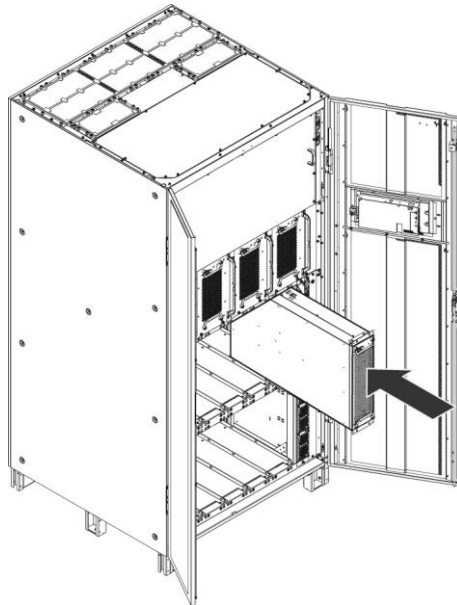

Figure 5-37: Insert the Power Module into the UPS Cabinet

Step 4

Use the four M6 screws and two M4 screws to fix the power module and metal windshield (provided in the accessory package) on the cabinet respectively. Whenever you install a power module, a metal windshield shall be installed.

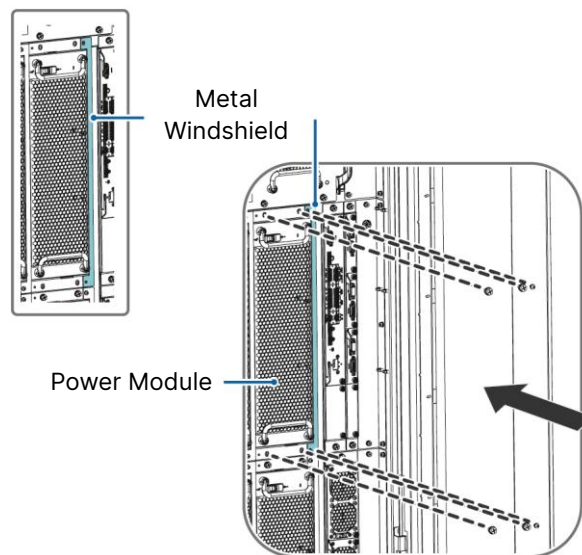



Figure 5-38: Fix the Power Module & Metal Windshield on the UPS Cabinet

Step 5

Turn the power module's switch to the upper position ().

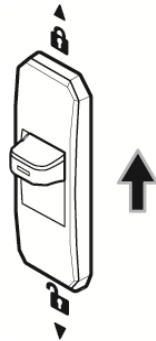

Figure 5-39: Turn the Power Module's Switch to the Upper Position

Step 6

Please note that any power module slot without installation of power module needs to be installed the power module slot cover. After finishing the steps mentioned above, use the four M6 screws (optional) to fix the power module slot cover (optional) on the UPS cabinet firmly. If you need the power module slot cover, you can purchase it.

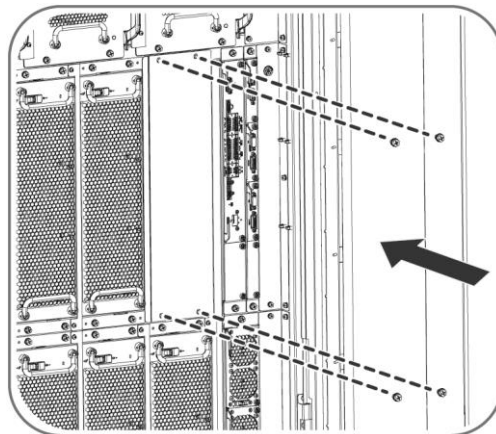

Figure 5-40: Install the Power Module Slot Cover on the UPS Cabinet

5.7.2 Power Module Removal



WARNING:

1. Only when (1) the UPS runs in manual bypass mode, (2) the capacitors are completely discharged and (3) the battery power is completely cut off can qualified service personnel perform the following removal procedures.
2. Before removing any power module, make sure that the remaining power module(s) can support the connected critical loads.
3. The power module is heavy (60 kg (132.28 lb)). At least three people are required for handling.
4. Before removing any power module, you should remove the power module slot cover located at the right side of the power module that you want to remove in order to facilitate the removal process.

Step 1

Turn the power module's switch to the lower position () and wait until the power module's LED indicator becomes off.

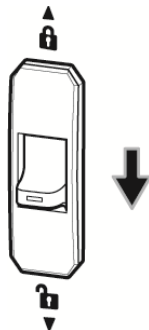

Figure 5-41: Turn the Power Module's Switch to the Lower Position

Step 2

Remove the four M6 screws, two M4 screws and the metal windshield from the power module.

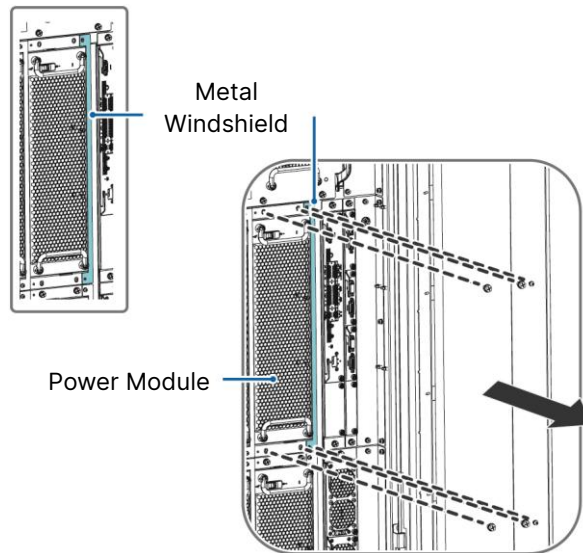

Figure 5-42: Remove the Four M6 Screws, Two M4 Screws & Metal Windshield from the Power Module

Step 3

Pull out the power module from the slot. When the power module cannot be pulled out any more, press the lock on the left side of the power module to continuously pull out the module from the UPS cabinet.

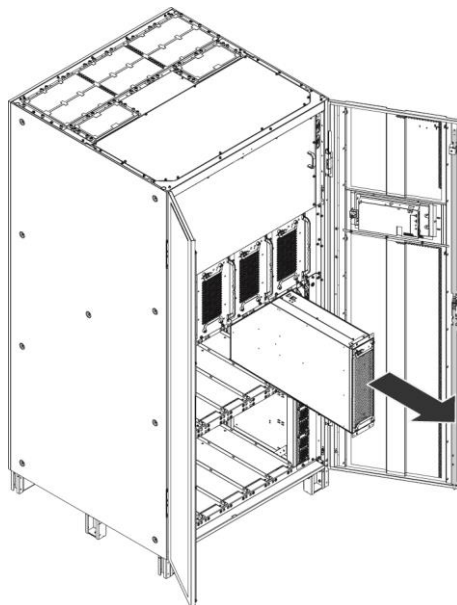

Figure 5-43: Remove the Power Module from the UPS Cabinet

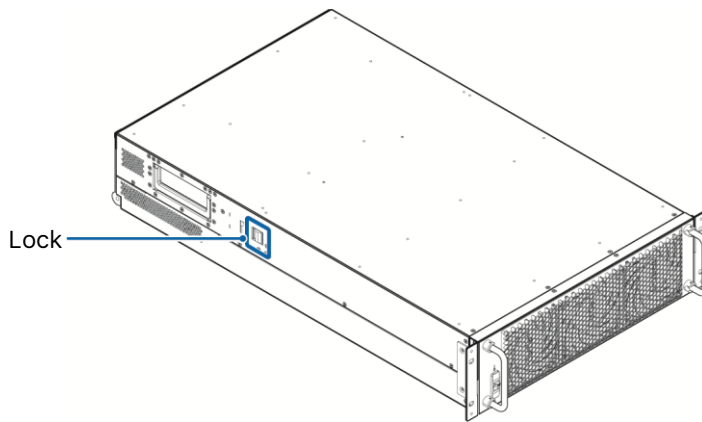

Figure 5-44: Press the Lock of the Power Module

5.7.3 Power Module's LED Indicator

The power module's LED indicator shows its operation status. Please refer to the following table.

LED Indicator	Description
OFF	The power module is OFF .
ON (green)	<ol style="list-style-type: none"> 1. The power module is running in On-Line mode or Battery mode. 2. The power module's inverter starts up. 3. The power module's PFC starts up.
Flashing (green)_ on for 2 seconds and off for 1 second	The power module is under discharging process.
Flashing (green)_ on for 0.3 seconds and off for 3 seconds	The power module is abnormal.



NOTE:

Under power module running conditions, if you turn the power module's switch to the lower position (⏻), the power module will shut down its output and discharge the DC BUS voltage until the voltage reaches to a safety level. After that, the power module's LED indicator will be off.

5.8 Installation of Rodent Shields

To prevent possible damage from rodents, please install the rodent shields (provided) at the bottom of the UPS.

Table 5-6: Quantity of Rodent Shield and M5 Screw

Rodent Shield Type	A	B	C	D
Rodent Shield Quantity	2 PCS	2 PCS	1 PC	1 PC
M5 Screw Quantity	8 PCS	8 PCS	4 PCS	4 PCS

Step 1

Install the rodent shields at the front and two lateral sides of the UPS bottom.

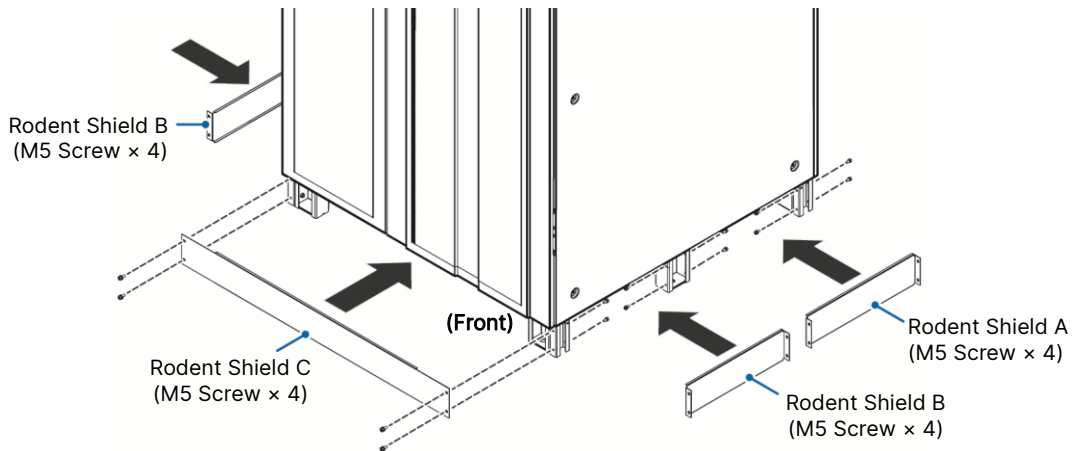

Figure 5-45: Install the Rodent Shields at the Front and Two Lateral Sides of the UPS Bottom

Step 2

Install the rodent shield at the rear of the UPS bottom.

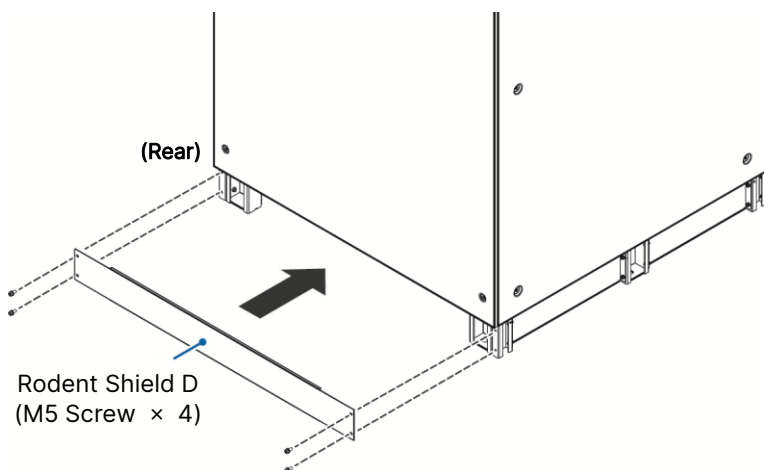



Figure 5-46: Install the Rodent Shield at the Rear of the UPS Bottom

Chapter 6 : UPS Operation

6.1 Pre Start-up & Pre Turn-off Warnings



NOTE:

1. All LCD diagrams in the user manual are for reference only. The display is subject to the actual status of the UPS.
2. For information about the LCD touch panel and tri-color LED indicator, please refer to *2.7 Tri-color LED Indicator & Buzzer* and *7. LCD Display & Settings*.
3. If the **ON/ OFF Button** (⏻) does not appear on the screen, please log in as **Administrator** first, and then go to  → **General Setting** → **User** → **On/ Off Button Access** to change the setting.

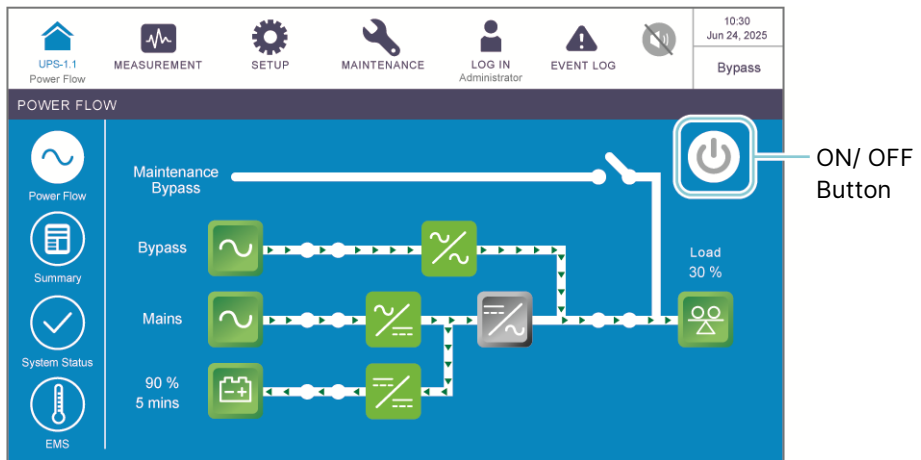

4. The external battery cabinet's breaker (Q5) shown on the LCD is always **ON** by default. To enable the detection of the Q5 status via the LCD, please contact Delta customer service for additional configurations.

- **Pre Start-up Warnings**

1. Before UPS operation, ensure that installation and wiring have been completely done according to *5. Installation and Wiring*, and relevant precautions and instructions have been followed. Make sure that the AC power's voltage, frequency, phase sequence and battery type meet the UPS's requirements.
2. Make sure that all the switches and breakers, including every external battery cabinet's breaker (Q5), are in the **OFF** position.
3. Do not turn off the external maintenance bypass cabinet's Output Switch (Q4) while the UPS is operating in any mode except for Manual Bypass mode. Otherwise, it may cause abnormalities or damage to the unit.

- **Pre Turn-off Warnings**

1. Before you perform the turn-off procedures, please make sure the critical loads connected to the UPS have already been safely shut down.
2. Please follow the turn-off procedures for each of the operation modes to shut down the UPS and make sure the external maintenance bypass cabinet's Output Switch (Q4) is the last one to be turned off. Otherwise, it may cause abnormalities or damage to the unit.

6.2 Start-up Procedures

6.2.1 On-Line Mode Start-up Procedures



WARNING:

Before turning on the UPS, please read *6.1 Pre Start-up & Pre Turn-off Warnings* thoroughly and ensure that the precautions and instructions have been followed.

Step 1

Ensure that the external maintenance bypass cabinet's Manual Bypass Switch (Q3) is in the **OFF** position.

Step 2

Switch **ON** every external battery cabinet's breaker (Q5).

Step 3

Switch **ON** the external maintenance bypass cabinet's Output Switch (Q4).

Step 4

Switch **ON** the external maintenance bypass cabinet's Bypass Switch (Q2), wait for the LCD initial screen, and switch **ON** the external maintenance bypass cabinet's Input Switch (Q1).

Step 5

Tap the **ON/ OFF Button** () on the LCD screen.

Step 6

After the inverter turns on, the UPS will run in On-Line mode, the LCD screen will show as below and the tri-color LED indicator will illuminate green.

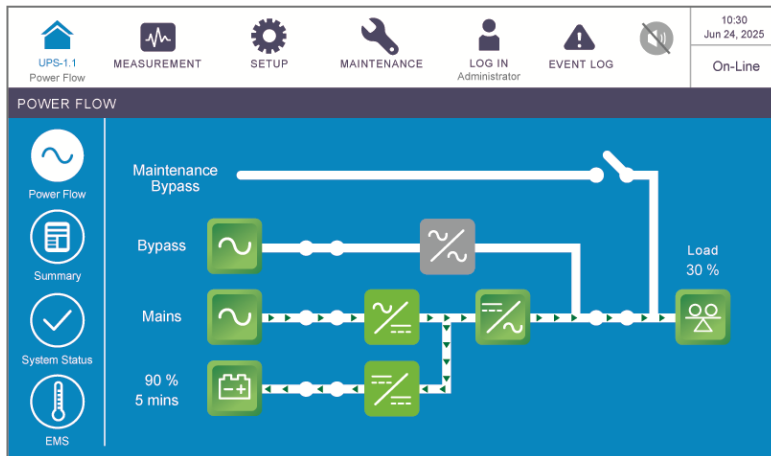

6.2.2 Battery Mode Start-up Procedures



WARNING:

Before turning on the UPS, please read **6.1 Pre Start-up & Pre Turn-off Warnings** thoroughly and ensure that the precautions and instructions have been followed.

Step 1

Ensure that the external maintenance bypass cabinet's Manual Bypass Switch (Q3) is in the **OFF** position.

Step 2

Switch **ON** every external battery cabinet's breaker (Q5).

Step 3

Switch **ON** the external maintenance bypass cabinet's Output Switch (Q4).

Step 4

Open the UPS's front doors and press the **BATT. START** button for one second.

Step 5

Tap the **ON/ OFF Button** (⏻) on the LCD screen.

Step 6

After the inverter turns on, the UPS will run in Battery mode, the LCD screen will show as below and the tri-color LED indicator will illuminate yellow.

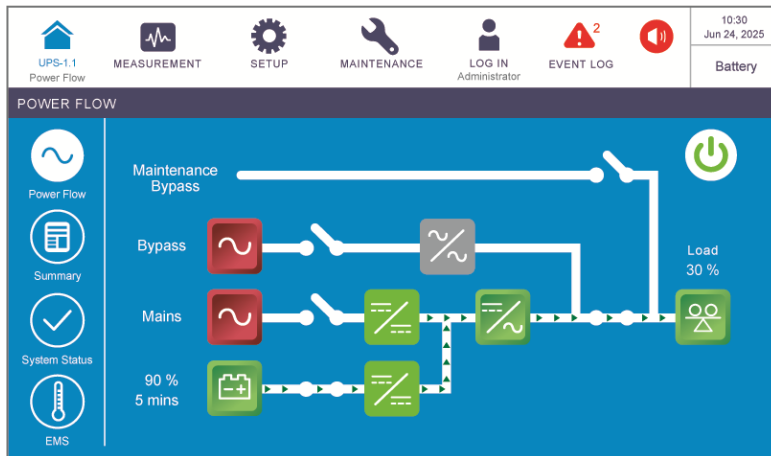

6.2.3 Bypass Mode Start-up Procedures



WARNING:

Before turning on the UPS, please read **6.1 Pre Start-up & Pre Turn-off Warnings** thoroughly and ensure that the precautions and instructions have been followed.

Step 1

Ensure that the external maintenance bypass cabinet's Manual Bypass Switch (Q3) is in the **OFF** position.

Step 2

Switch **ON** the external maintenance bypass cabinet's Output Switch (Q4).

Step 3

Switch **ON** the external maintenance bypass cabinet's Bypass Switch (Q2).

Step 4

Now, the UPS runs in Bypass mode, the LCD screen shows as below and the tri-color LED indicator illuminates yellow.

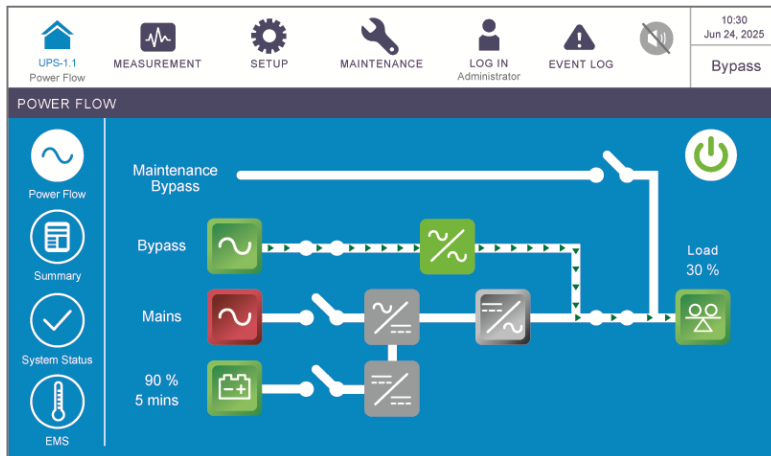

6.2.4 Manual Bypass Mode Start-up Procedures



WARNING:

1. Before turning on/ off the UPS, please read **6.1 Pre Start-up & Pre Turn-off Warnings** thoroughly and ensure that the precautions and instructions have been followed.
2. In Manual Bypass Mode, make sure that all of the switches and breakers (except for the external maintenance bypass cabinet's Manual Bypass Switch (Q3)) are in the **OFF** position before working on the UPS's internal circuits to prevent electric shock. **DO NOT** touch any terminal and bus bar which may carry high-voltage electricity.

- **From On-Line Mode to Manual Bypass Mode**

Step 1

Tap the **ON/ OFF Button** (🔌) on the LCD screen to shut down the inverter.

Step 2

Ensure that the UPS runs in Bypass mode. After confirmation, turn **ON** the external maintenance bypass cabinet's Manual Bypass Switch (Q3).

Step 3

Switch **OFF** the external maintenance bypass cabinet's Input Switch (Q1) and Bypass Switch (Q2). After that, the LCD screen shows as follows.

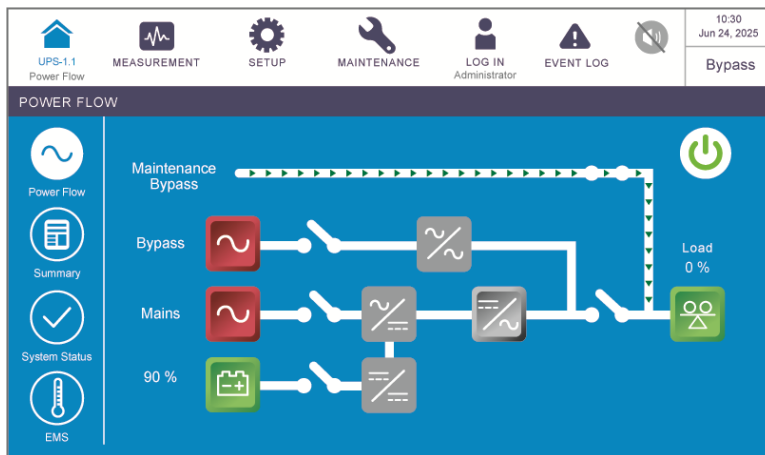

Step 4

Wait for the UPS to complete DC BUS discharging. After discharging, switch **OFF** every external battery cabinet's breaker (Q5), and the LCD and tri-color LED indicator will be off.

Step 5

Switch **OFF** the external maintenance bypass cabinet's Output Switch (Q4).

- **From Manual Bypass Mode to On-Line Mode**

Step 1

Switch **ON** every external battery cabinet's breaker (Q5).

Step 2

Switch **ON** the external maintenance bypass cabinet's Output Switch (Q4).

Step 3

Switch **ON** the external maintenance bypass cabinet's Bypass Switch (Q2), wait for the LCD initial screen, and switch **ON** the external maintenance bypass cabinet's Input Switch (Q1). After that, ensure that the bypass SCR is active.

Step 4

Switch **OFF** the external maintenance bypass cabinet's Manual Bypass Switch (Q3).

Step 5

Tap the **ON/ OFF Button** (🔌) on the LCD screen.

Step 6

After the inverter turns on, the UPS will run in On-Line mode, the LCD screen will show as below and the tri-color LED indicator will illuminate green.

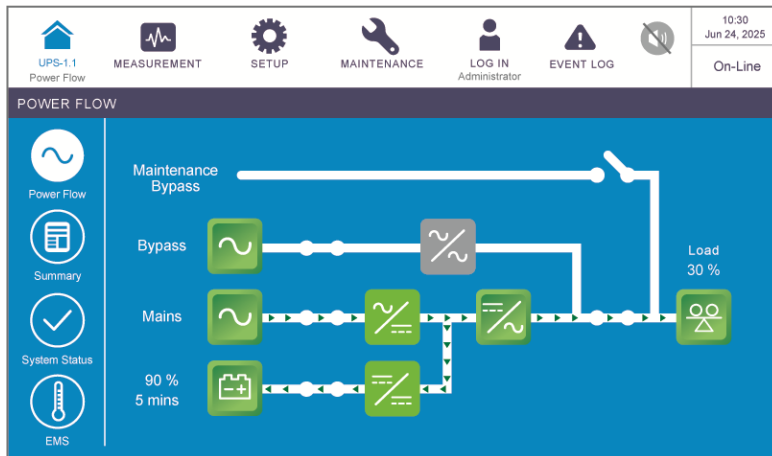

6.2.5 ECO Mode Start-up Procedures



WARNING:

Before turning on the UPS, please read **6.1 Pre Start-up & Pre Turn-off Warnings** thoroughly and ensure that the precautions and instructions have been followed.

Step 1

Ensure that the external maintenance bypass cabinet's Manual Bypass Switch (Q3) is in the **OFF** position.

Step 2

Switch **ON** every external battery cabinet's breaker (Q5).

Step 3

Switch **ON** the external maintenance bypass cabinet's Output Switch (Q4).

Step 4

Switch **ON** the external maintenance bypass cabinet's Bypass Switch (Q2), wait for the LCD initial screen, and switch **ON** the external maintenance bypass cabinet's Input Switch (Q1).

If the bypass input is within the normal range, the UPS will run in Bypass mode.

Step 5

Log in as **Administrator**. For the **Administrator** password, please contact service personnel.

Administrator Login

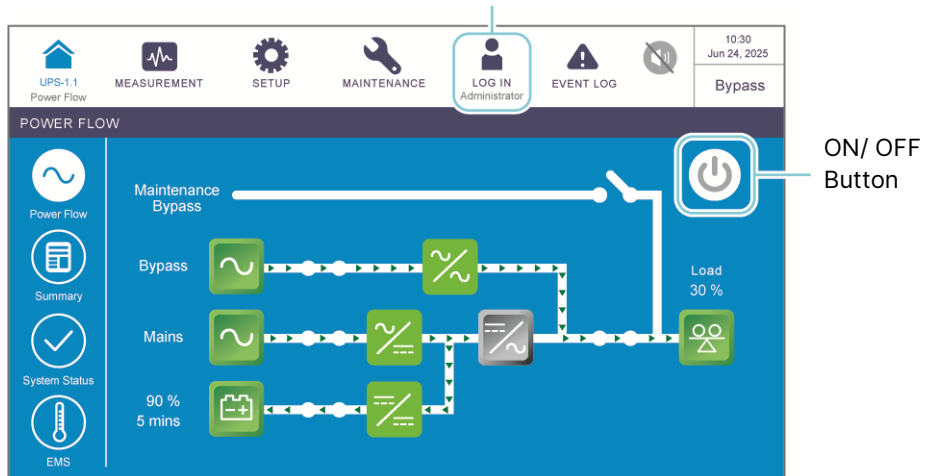
**Step 6**

Go to **SETUP** → **Mode Setting** → Select **ECO**.

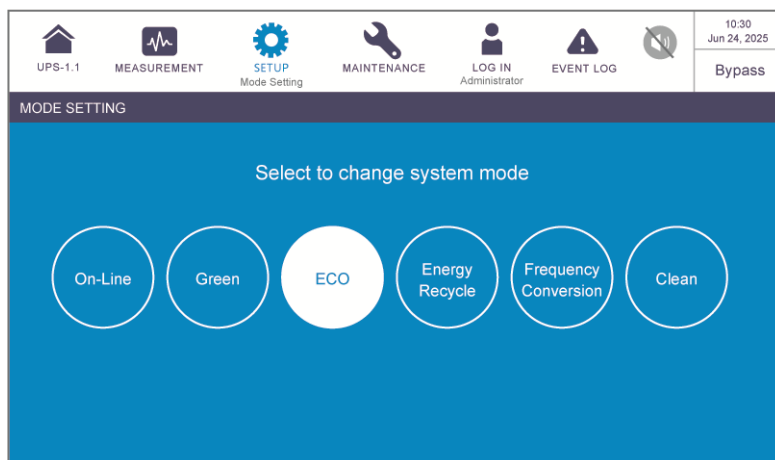
**Step 7**

Tap the icon (🏠) to go back to the **Main Screen** and tap the **ON/ OFF Button** (🔌).

Step 8

After the inverter turns on and the system confirms that the bypass voltage is normal, the UPS will automatically transfer to ECO mode to let the bypass supply power, the LCD screen will show as below and the tri-color LED indicator will illuminate green.

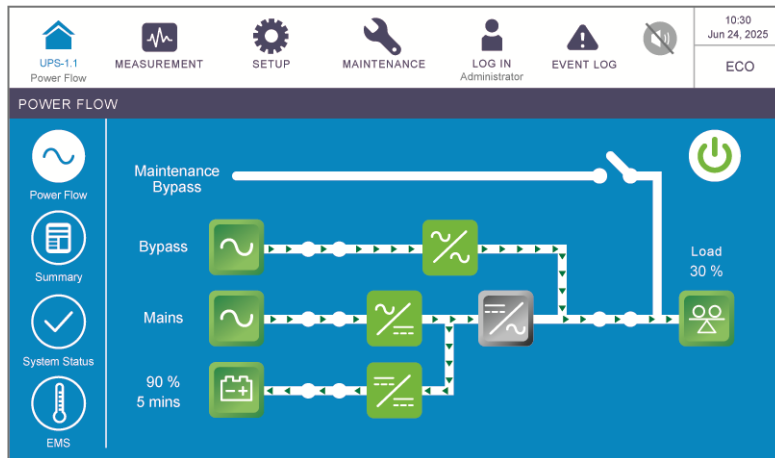

6.2.6 Green Mode Start-up Procedures



WARNING:

Before turning on the UPS, please read *6.1 Pre Start-up & Pre Turn-off Warnings*

thoroughly and ensure that the precautions and instructions have been followed.

Step 1

Ensure that the external maintenance bypass cabinet's Manual Bypass Switch (Q3) is in the **OFF** position.

Step 2

Switch **ON** every external battery cabinet's breaker (Q5).

Step 3

Switch **ON** the external maintenance bypass cabinet's Output Switch (Q4).

Step 4

Switch **ON** the external maintenance bypass cabinet's Bypass Switch (Q2), wait for the LCD initial screen, and switch **ON** the external maintenance bypass cabinet's Input Switch (Q1).

If the bypass input is within the normal range, the UPS will run in Bypass mode.

Step 5

Log in as **Administrator**. For the **Administrator** password, please contact service personnel.

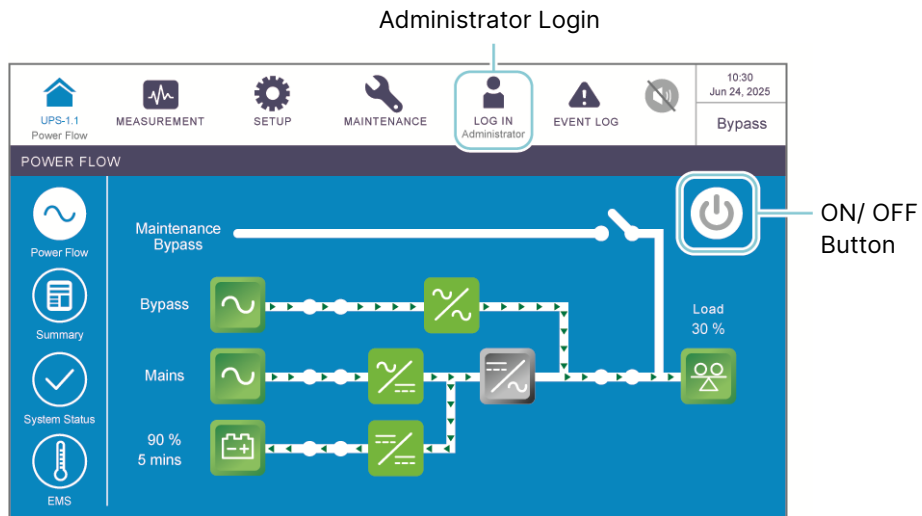

Step 6

Go to **SETUP** → **Mode Setting** → Select **Green**.

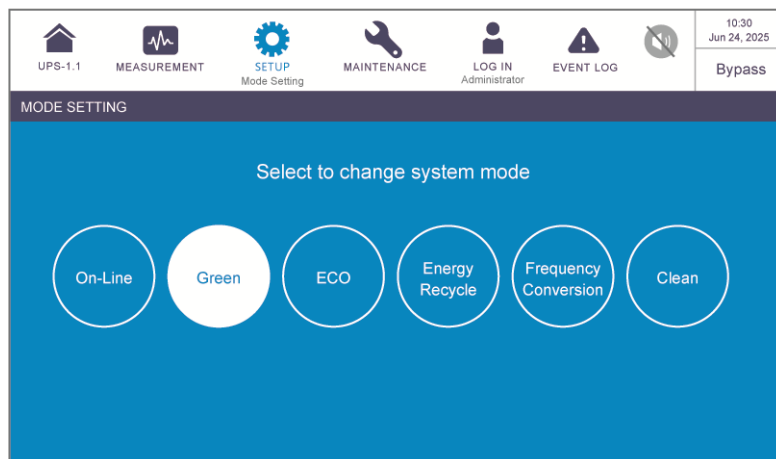

Step 7

Tap the icon (🏠) to go back to the **Main Screen** and tap the **ON/ OFF Button** (🔌).

Step 8

Now, the UPS automatically transfers to run in Green mode and the system automatically detects the output status (i.e. total load capacity %) to decide which specific power module(s) should be fully powered on or idle in order to achieve higher efficiency of the UPS. The LCD screen shows as below and the tri-color LED indicator illuminates green.

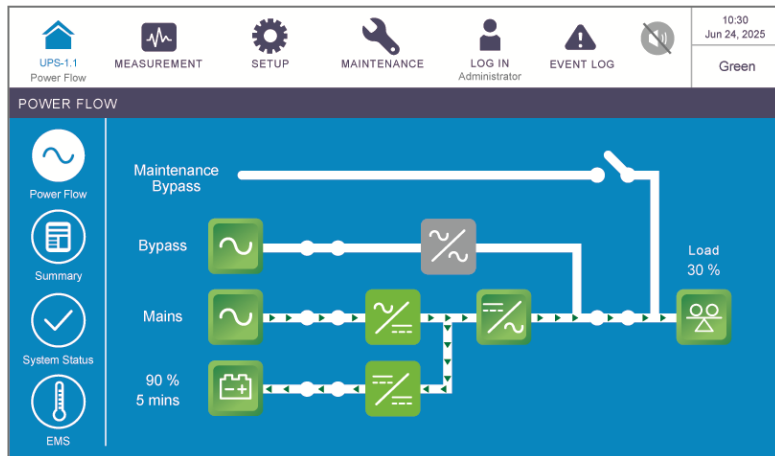

6.2.7 Clean Mode Start-up Procedures



WARNING:

Before turning on the UPS, please read *6.1 Pre Start-up & Pre Turn-off Warnings*

thoroughly and ensure that the precautions and instructions have been followed.

Step 1

Ensure that the external maintenance bypass cabinet's Manual Bypass Switch (Q3) is in the **OFF** position.

Step 2

Switch **ON** every external battery cabinet's breaker (Q5).

Step 3

Switch **ON** the external maintenance bypass cabinet's Output Switch (Q4).

Step 4

Switch **ON** the external maintenance bypass cabinet's Bypass Switch (Q2), wait for the LCD initial screen, and switch **ON** the external maintenance bypass cabinet's Input Switch (Q1).

If the bypass input is within the normal range, the UPS will run in Bypass mode.

Step 5

Log in as **Administrator**. For the **Administrator** password, please contact service personnel.

Administrator Login

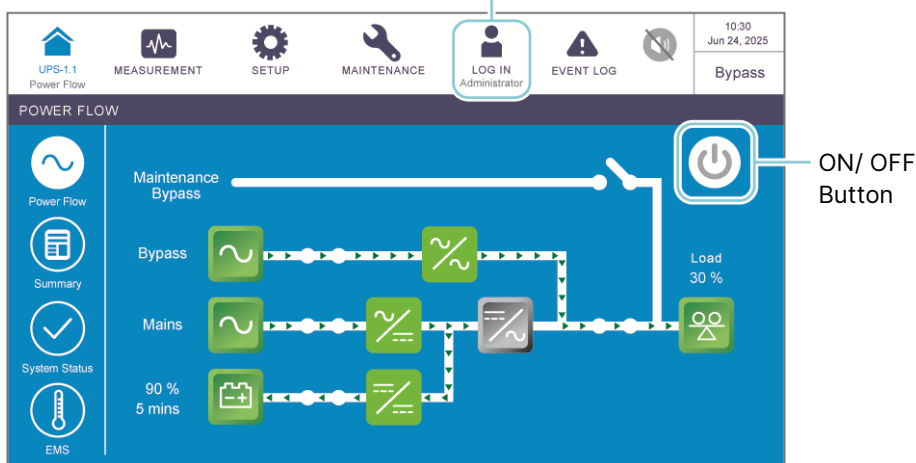

Step 6

Go to **SETUP** → **Mode Setting** → Select **Clean**.

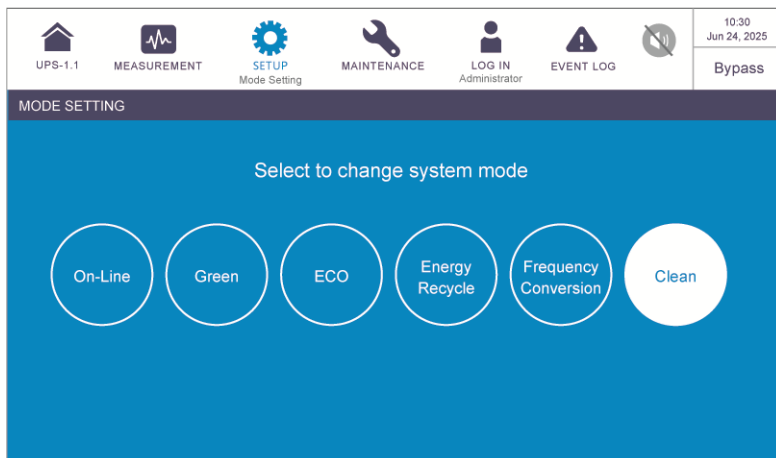

Step 7

Tap the icon (🏠) to go back to the **Main Screen** and tap the **ON/ OFF Button** (🔌).

Step 8

Now, the UPS automatically transfers to run in Clean mode and the system automatically detects the output status to let the inverter provide active filter function to compensate harmonics, correct power factor and reduce bypass reactive current to improve overall power quality. The LCD screen shows as below and the tri-color LED indicator illuminates green.

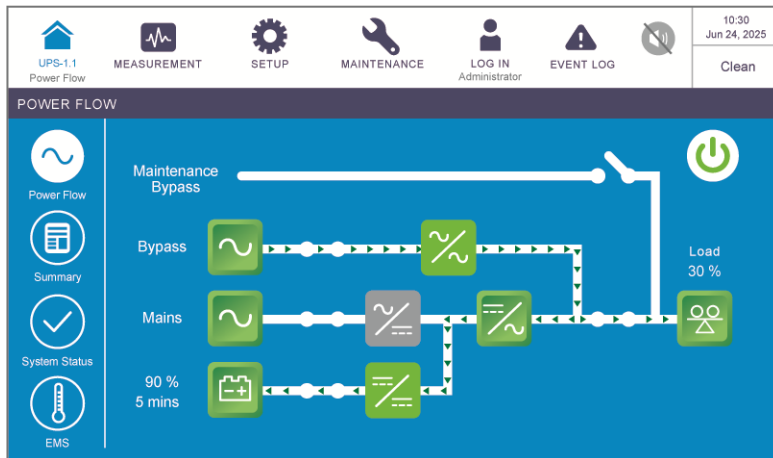

6.2.8 Frequency Conversion Mode Start-up Procedures



WARNING:

1. Before turning on the UPS, please read *6.1 Pre Start-up & Pre Turn-off Warnings* thoroughly and ensure that the precautions and instructions have been followed.
2. Frequency Conversion mode is only applicable to single UPS but not to parallel UPSs.
3. When the UPS runs in Frequency Conversion mode, once the inverter becomes off, there is no bypass power supplying to the loads.

Step 1

Ensure that the external maintenance bypass cabinet's Manual Bypass Switch (Q3) is in the **OFF** position.

Step 2

Switch **ON** every external battery cabinet's breaker (Q5).

Step 3

Turn **OFF** the connected loads to prevent wrong frequency from damaging the loads. After that, switch **ON** the external maintenance bypass cabinet's Output Switch (Q4).

Step 4

Switch **ON** the external maintenance bypass cabinet's Bypass Switch (Q2), wait for the LCD initial screen, and switch **ON** the external maintenance bypass cabinet's Input Switch (Q1).

If the bypass input is within the normal range, the UPS will run in Bypass mode.

Step 5

Log in as **Administrator**. For the **Administrator** password, please contact service personnel.

Administrator Login

**Step 6**

Go to **SETUP** → **Mode Setting** → Select **Frequency Conversion**.

**WARNING:**

Once you select '**Frequency Conversion**' mode, the UPS will run in Standby mode and the output will be terminated.

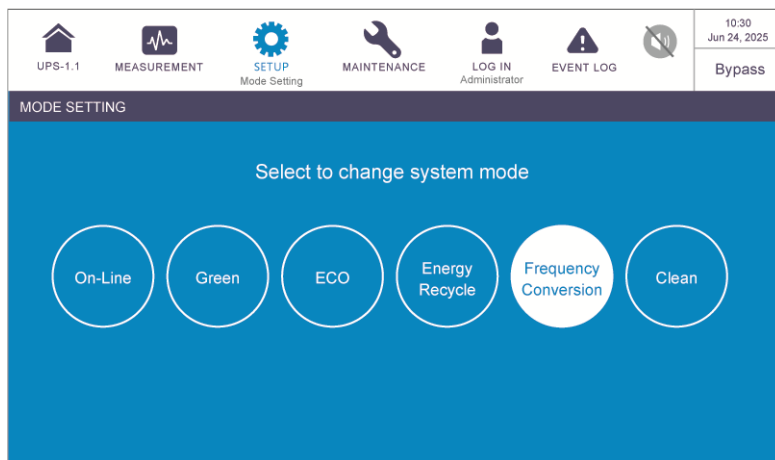
**Step 7**

Tap the icon () to go back to the **Main Screen** and tap the **ON/ OFF Button** ()

Step 8

After the inverter turns on, the UPS will run in Frequency Conversion mode, the output frequency will be the same as the setup value, the LCD screen will show as below and the tri-color LED indicator will illuminate green.

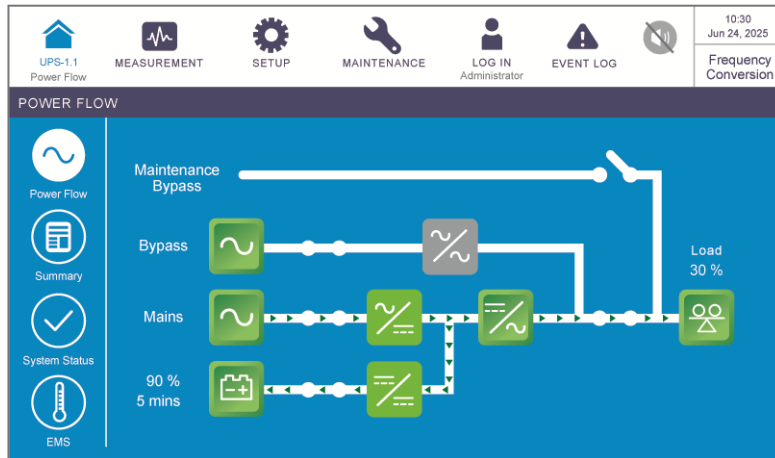

6.2.9 Energy Recycle Mode Start-up Procedures



WARNING:

1. Before turning on the UPS, please read **6.1 Pre Start-up & Pre Turn-off Warnings** thoroughly and ensure that the precautions and instructions have been followed.
2. Energy Recycle mode is only applicable to single unit application.
3. Only qualified personnel can perform the following procedure.

Step 1

Ensure that the external maintenance bypass cabinet's Manual Bypass Switch (Q3) is in the **OFF** position.

Step 2

Switch **ON** every external battery cabinet's breaker (Q5).

Step 3

Switch **ON** the external maintenance bypass cabinet's Bypass Switch (Q2), wait for the LCD initial screen and switch **ON** the external maintenance bypass cabinet's Input Switch (Q1).

If the bypass input is within the normal range, the UPS will run in Bypass mode.

Step 4

Switch **OFF** the external maintenance bypass cabinet's Output Switch (Q4).

Step 5

Log in as **Administrator**. For the **Administrator** password, please contact service personnel.

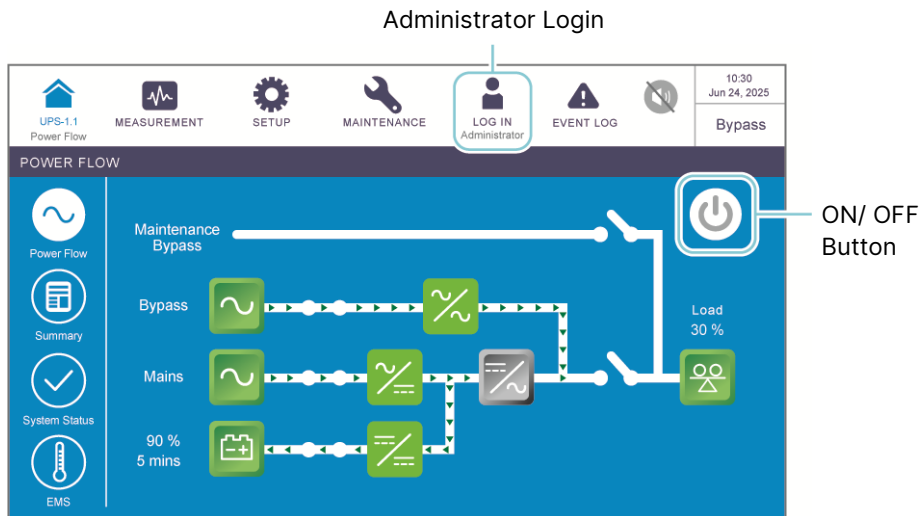

Step 6

Go to **SETUP** → **Mode Setting** → Select **Energy Recycle**.

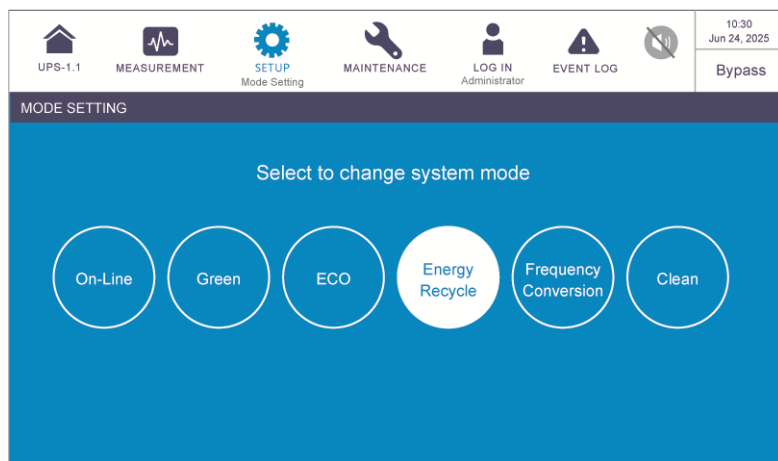

Step 7

Tap the icon (🏠) to go back to the **Main Screen** and tap the **ON/ OFF Button** (🔌).

Step 8

Now, the UPS automatically transfers to run in Energy Recycle mode. The LCD screen shows as below and the tri-color LED indicator illuminates yellow. For Energy Recycle mode application, please contact Delta customer service.

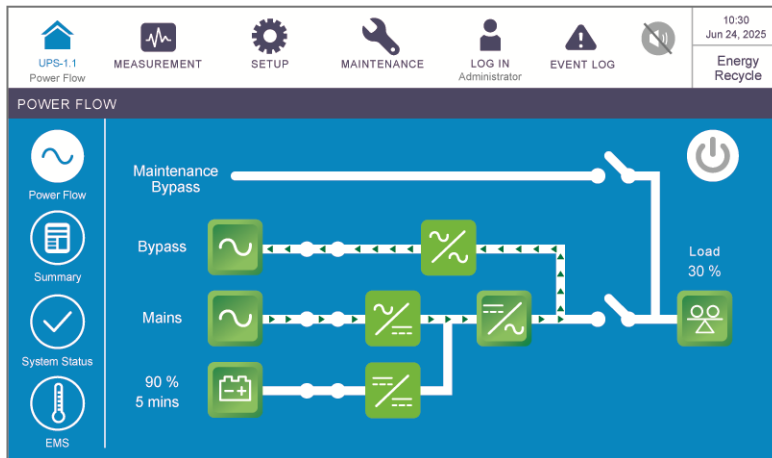

6.3 Turn-off Procedures

6.3.1 On-Line Mode Turn-off Procedures



WARNING:

Before turning off the UPS, please read **6.1 Pre Start-up & Pre Turn-off Warnings** thoroughly and ensure that the precautions and instructions have been followed.

Step 1

Tap the **ON/ OFF Button** (🔌) to shut down the UPS's inverter. After that, the UPS will let the bypass AC source supply power. At the moment, if the bypass is abnormal, there is a risk of output interruption.

Step 2

Switch **OFF** the external maintenance bypass cabinet's Input Switch (Q1) and Bypass Switch (Q2). After that, the UPS will transfer to Standby mode.

Step 3

Wait for the UPS to complete the DC BUS discharging. After that, switch **OFF** each external battery cabinet's breaker (Q5), and the LCD screen and tri-color LED indicator will be off.

Step 4

Switch **OFF** the external maintenance bypass cabinet's Output Switch (Q4).

6.3.2 Battery Mode Turn-off Procedures



WARNING:

Before turning off the UPS, please read *6.1 Pre Start-up & Pre Turn-off Warnings* thoroughly and ensure that the precautions and instructions have been followed.

Step 1

Please make sure that the critical loads connected to the UPS have already been safely shut down. After confirmation, tap the **ON/ OFF Button** () to shut down the UPS's inverter. Note that once you turn off the inverter, all the output power will be completely cut off, and the UPS will transfer to Standby mode.

Step 2

Switch **OFF** the external maintenance bypass cabinet's Input Switch (Q1) and Bypass Switch (Q2).

Step 3

Wait for the UPS to complete the DC BUS discharging. After that, switch **OFF** each external battery cabinet's breaker (Q5), and the LCD and tri-color LED indicator will be off.

Step 4

Switch **OFF** the external maintenance bypass cabinet's Output Switch (Q4).

6.3.3 Bypass Mode Turn-off Procedures



WARNING:

Before turning off the UPS, please read *6.1 Pre Start-up & Pre Turn-off Warnings* thoroughly and ensure that the precautions and instructions have been followed.

Step 1

Switch **OFF** the external maintenance bypass cabinet's Input Switch (Q1) and Bypass Switch (Q2). After that, the UPS will transfer to Standby mode.

Step 2

Wait for the UPS to complete the DC BUS discharging. After that, switch **OFF** each external battery cabinet's breaker (Q5), and the LCD and tri-color LED indicator will be off.

Step 3

Switch **OFF** the external maintenance bypass cabinet's Output Switch (Q4).

6.3.4 Manual Bypass Mode Turn-off Procedures



WARNING:

1. Ensure that the LCD, all LED indicators and fans are **OFF**.
2. Check that all the switches, breakers and power are **OFF**.

In Manual Bypass mode, the LCD and tri-color LED indicator are both **OFF**. To completely shut down the UPS, switch **OFF** the external maintenance bypass cabinet's Manual Bypass Switch (Q3).

6.3.5 ECO Mode Turn-off Procedures



WARNING:

Before turning off the UPS, please read *6.1 Pre Start-up & Pre Turn-off Warnings* thoroughly and ensure that the precautions and instructions have been followed.

Step 1

Tap the **ON/ OFF Button** () to shut down the UPS's inverter. After that, the UPS will let the bypass AC source supply power. At the moment, if the bypass is abnormal, there is a risk of output interruption.

Step 2

Switch **OFF** the external maintenance bypass cabinet's Input Switch (Q1) and Bypass Switch (Q2). After that, the UPS will transfer to Standby mode.

Step 3

Wait for the UPS to complete the DC BUS discharging. After that, switch **OFF** each external battery cabinet's breaker (Q5), and the LCD and tri-color LED indicator will be off.

Step 4

Switch **OFF** the external maintenance bypass cabinet's Output Switch (Q4).

6.3.6 Green Mode Turn-off Procedures



WARNING:

Before turning off the UPS, please read *6.1 Pre Start-up & Pre Turn-off Warnings* thoroughly and ensure that the precautions and instructions have been followed.

Step 1

Tap the **ON/ OFF Button** () to shut down the UPS's inverter. After that, the UPS will let the bypass AC source supply power. At the moment, if the bypass is abnormal, there is a risk of output interruption.

Step 2

Switch **OFF** the external maintenance bypass cabinet's Input Switch (Q1) and the Bypass Switch (Q2). After that, the UPS will transfer to Standby mode.

Step 3

Wait for the UPS to complete the DC BUS discharging. After that, switch **OFF** each external battery cabinet's breaker (Q5), and the LCD and tri-color LED indicator will be off.

Step 4

Switch **OFF** the external maintenance bypass cabinet's Output Switch (Q4).

6.3.7 Clean Mode Turn-off Procedures**WARNING:**

Before turning off the UPS, please read *6.1 Pre Start-up & Pre Turn-off Warnings* thoroughly and ensure that the precautions and instructions have been followed.

Step 1

Tap the **ON/ OFF Button** () to shut down the UPS's inverter. After that, the UPS will let the bypass AC source supply power. At the moment, if the bypass is abnormal, there is a risk of output interruption.

Step 2

Switch **OFF** the external maintenance bypass cabinet's Input Switch (Q1) and the Bypass Switch (Q2). After that, the UPS will transfer to Standby mode.

Step 3

Wait for the UPS to complete the DC BUS discharging. After that, switch **OFF** each external battery cabinet's breaker (Q5), and the LCD and tri-color LED indicator will be off.

Step 4

Switch **OFF** the external maintenance bypass cabinet's Output Switch (Q4).

6.3.8 Frequency Conversion Mode Turn-off Procedures**WARNING:**

Before turning off the UPS, please read *6.1 Pre Start-up & Pre Turn-off Warnings* thoroughly and ensure that the precautions and instructions have been followed.

Step 1

Please make sure that the critical loads connected to the UPS have already been safely shut down. After confirmation, tap the **ON/ OFF Button** () to shut down the UPS's inverter. Note that once you turn off the inverter, all the output power will be completely cut off, and the UPS will transfer to Standby mode. Now, the power modules keep charging the batteries.

Step 2

Switch **OFF** the external maintenance bypass cabinet's Input Switch (Q1) and Bypass Switch (Q2).

Step 3

Wait for the UPS to complete the DC BUS discharging. After that, switch **OFF** each external battery cabinet's breaker (Q5), and the LCD and tri-color LED indicator will be off.

Step 4

Switch **OFF** the external maintenance bypass cabinet's Output Switch (Q4).

6.3.9 Energy Recycle Mode Turn-off Procedure



WARNING:

Before turning off the UPS, please read *6.1 Pre Start-up & Pre Turn-off Warnings* thoroughly and ensure that the precautions and instructions have been followed.

Step 1

Tap the **ON/ OFF Button** () to shut down the UPS's inverter. After that, the UPS will let the bypass AC source supply power. At the moment, if the bypass is abnormal, there is a risk of output interruption.

Step 2

Switch **OFF** the external maintenance bypass cabinet's Input Switch (Q1) and Bypass Switch (Q2). After that, the UPS will transfer to Standby mode.

Step 3

Wait for the UPS to complete the DC BUS discharging. After that, switch **OFF** each external battery cabinet's breaker (Q5), and the LCD and tri-color LED indicator will be off.

Step 4

Switch **OFF** the external maintenance bypass cabinet's Output Switch (Q4).

6.4 Start-up & Turn off Procedures for Parallel Units



WARNING:

1. Before turning on the UPS, please read **6.1 Pre Start-up & Pre Turn-off Warnings** thoroughly and ensure that the precautions and instructions have been followed.
2. Ensure that every operation procedure is synchronized to all parallel UPSs. If you just want to operate a specific UPS but not all the parallel ones, please contact service personnel.

- **Start-up Procedures (Parallel Units)**

Step 1

Ensure that each parallel cable (provided) is connected well.

Step 2

Perform the first few steps following your chosen mode's section in **6.2 Start-up Procedures** until there is power supplying to the UPS (after switching **ON** Q1/ Q2 or pressing the **BATT. START** button)*1.



NOTE:

*1 For common battery configurations, you must switch **ON** each parallel UPS's external maintenance bypass cabinet's Input Switch (Q1), Bypass Switch (Q2) or Input Switch (Q1) and Bypass Switch (Q2) or execute battery start-up to start up the UPS first. After that, you can follow **6.2 Start-up Procedures** according to your chosen mode to perform parallel units' start-up procedures.

At this moment, please perform the following parallel settings on the LCD.

- a. Assign a different **Parallel ID** no.to each parallel UPS. For all the parallel UPSs, please set the same **Parallel Group ID** no. and the same parameters for the input, output and battery settings.
- b. Tap the icon () to check if the **Parallel Group ID** no. and **Parallel ID** no. are set properly. The UPS with the smallest **Parallel ID** no. is the master UPS.

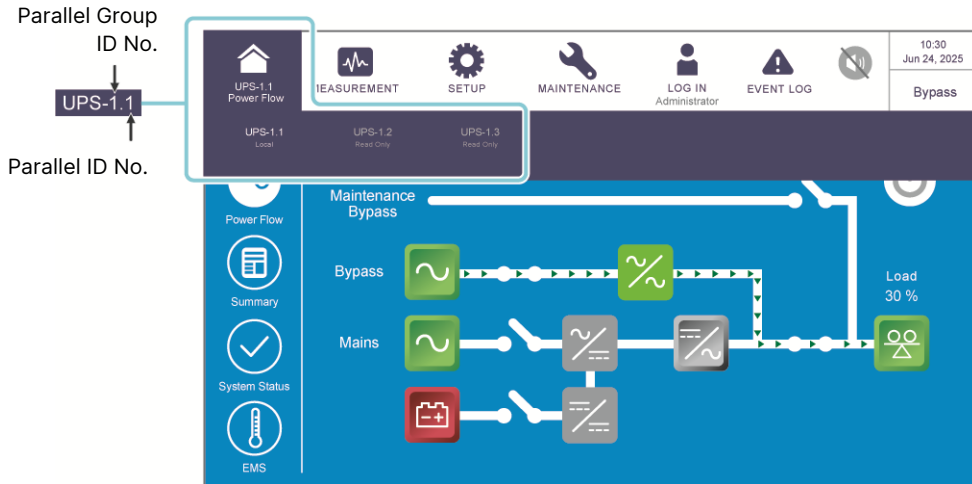

Step 3

Complete the rest of the steps in **6.2 Start-up Procedures** according to your chosen mode.

Step 4

Ensure that the output voltage difference between each parallel UPS is below 3V. Only authorized Delta engineers or service personnel can check the output voltage difference, or it must be done under the supervision of authorized Delta engineers or service personnel.

Step 5

Now, the UPSs are ready to operate in parallel.

- **Turn-off Procedures (Parallel Units)**



WARNING:

To turn off one of the parallel UPSs, please check whether the remaining parallel units' total capacity exceeds the total critical loads. Otherwise, all parallel units will shut down due to overload. Before doing this, please contact service personnel.

Perform the steps following your chosen mode's section in **6.3 Turn-off Procedures**. Make sure to synchronize each step to all the parallel UPSs.

Chapter 7 : LCD Display & Settings

7.1 LCD Display Hierarchy

Please refer to *Figure 7-1* for an overview of all the LCD items. For some of the items marked with an asterisk, they will show up only under certain conditions. Please refer to the note below for details.

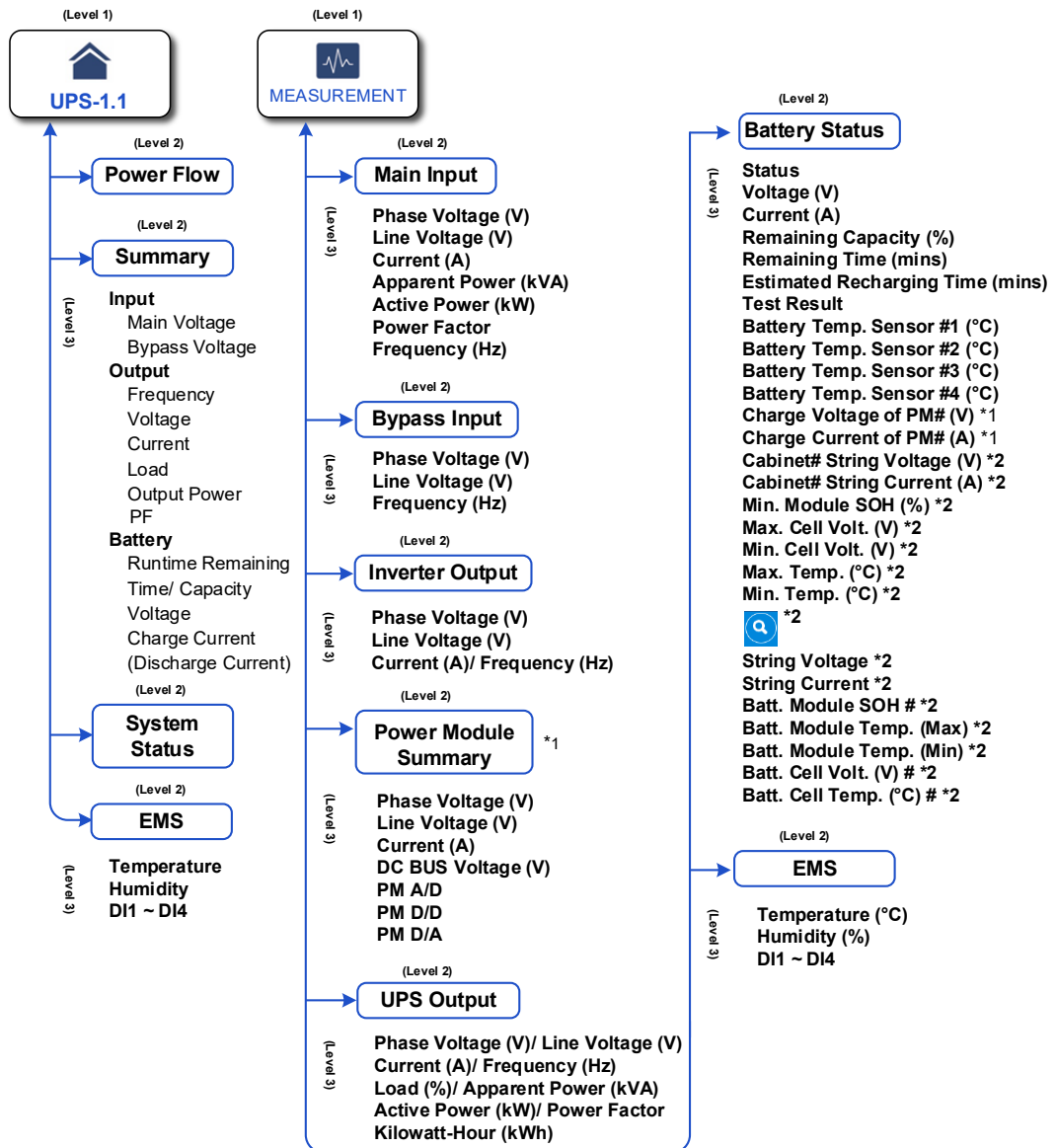

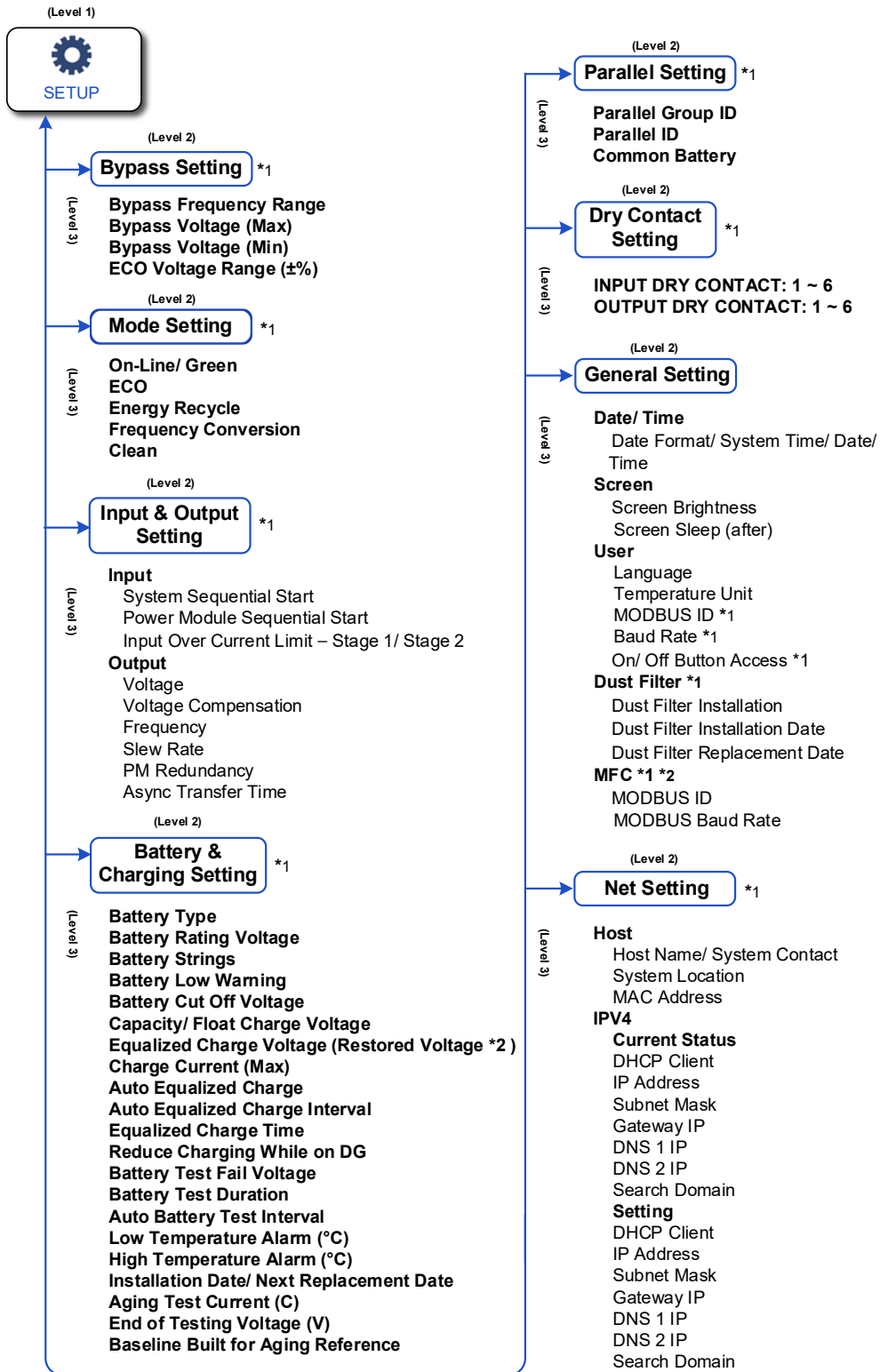

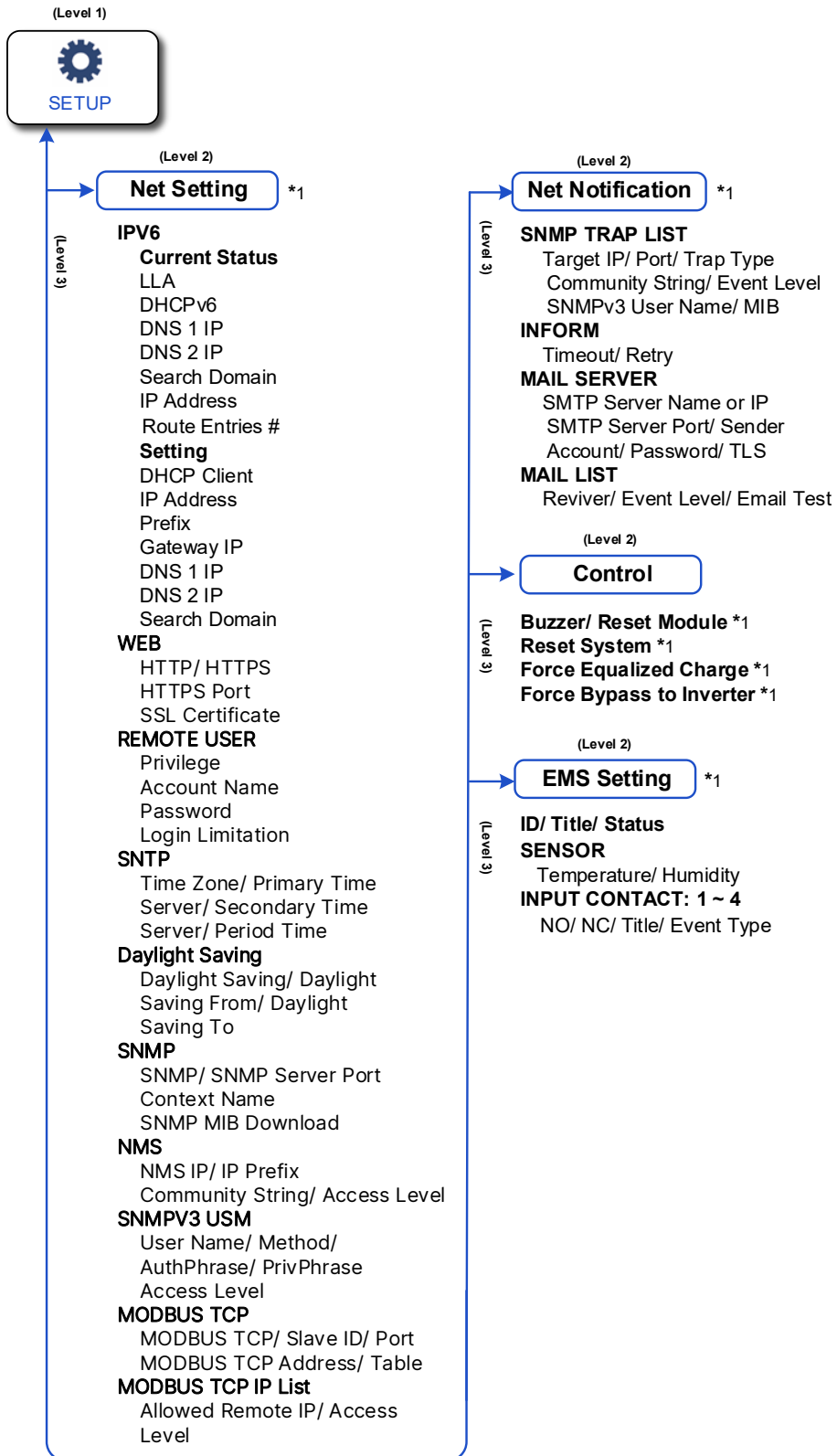

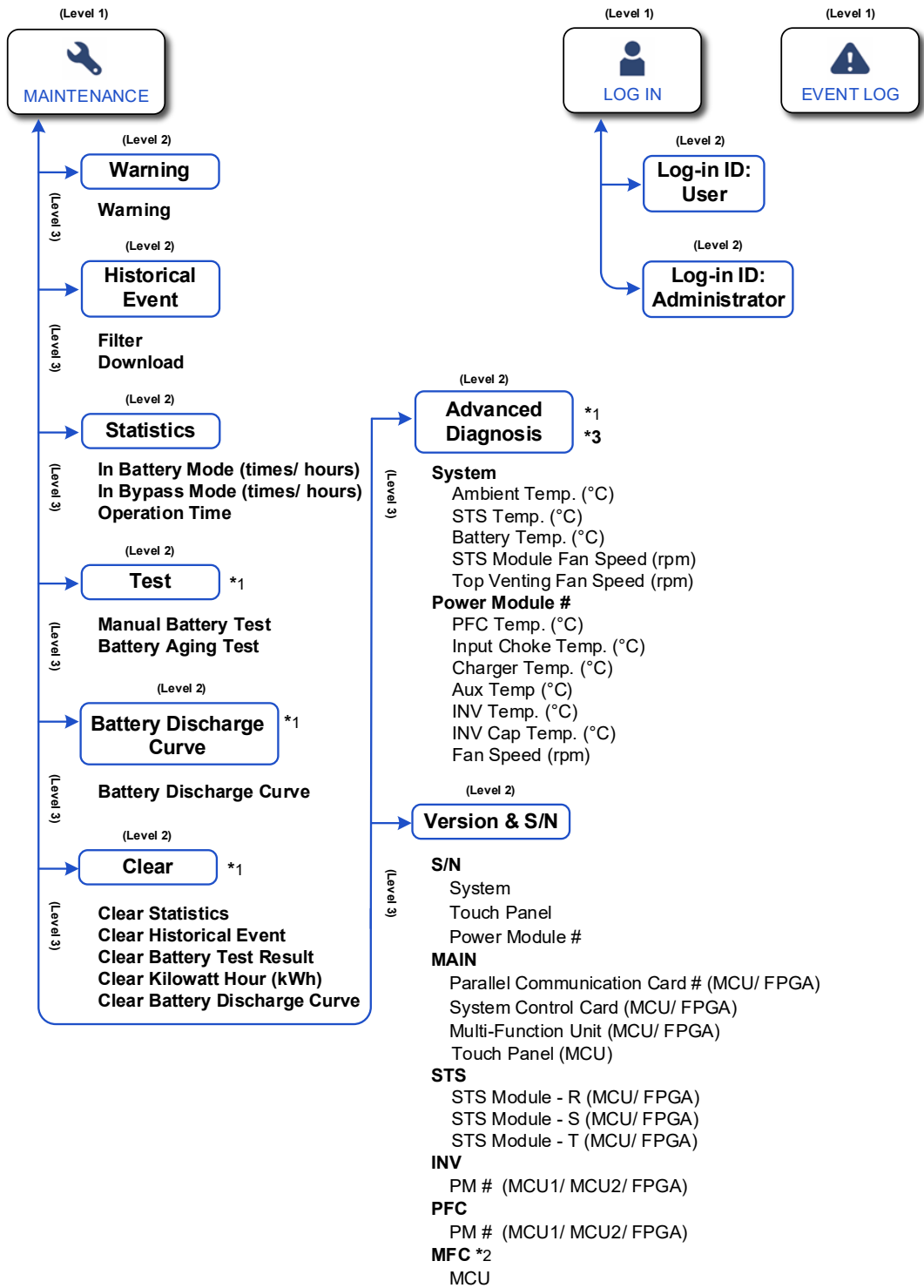

Figure 7-1: LCD Display Hierarchy

**NOTE:**

1. For **EMS/ EMS Setting**, the functions will be activated only after proper installation and settings of the optional accessories have been completed. For details, refer to **8. Optional Accessories**.
2. *¹ To display the item(s), you have to log in as **Administrator**. Please refer to **7.4 Password Entry**.
 - *² The item(s) will show up only when you use the Delta lithium-ion batteries and have installed the optional multifunctional communication card (MFC) in the SMART slot.
 - *³ The function is optional. If you need to activate it, please contact Delta customer service.
3. The LCD screen diagrams in the user manual are for reference only. The actual display depends on the operation situation.

7.2 How to Turn on the LCD

Step 1

Perform one of the options (a ~ d) below; after that, the LCD will be on.

- a*¹. Turn on the external maintenance bypass cabinet's Input Switch (Q1); or
- b*¹. Turn on the external maintenance bypass cabinet's Bypass Switch (Q2); or
- c*¹. Turn on the external maintenance bypass cabinet's Input Switch (Q1) and Bypass Switch (Q2); or
- d. Turn on any external battery cabinet's breaker (Q5) and press the battery start button (see **Figure 4-1**) for 1 second.

**NOTE:**

- *¹ Before turning on (Q1) or (Q2) or (Q1) and (Q2), please confirmed that the STS module has been installed properly; otherwise, the LCD won't be turned on even if you follow the procedures mentioned in a, b or c.

Step 2

A short while later, the **Main Screen** will appear with **User Login** status and the **ON/ OFF Button** (⏻).





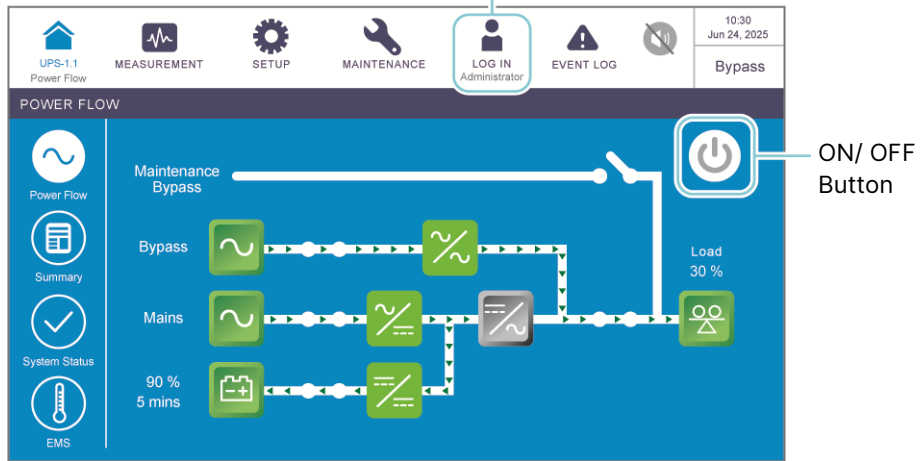

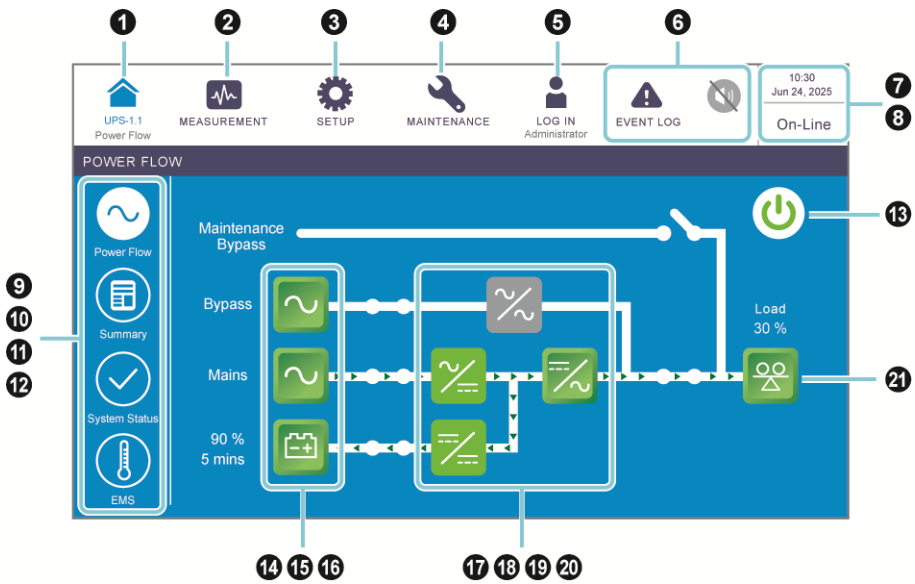

If the **ON/ OFF Button** (⏻) does not appear on the screen, please log in as **Administrator** first, and then go to  → **General Setting** → **User** → **On/ Off Button Access** to change the setting.















Administrator Login













7.3 Introduction of Touch Panel and Function Keys



















No.	Icon/ Text	Button Function (Yes or No)	Text/ Digital Display (Yes or No)	Symbol Display (Yes or No)	Description
1		✓	✓		<p>Tap the button to go back to the Main Screen. The figure (<i>UPS-1.1</i>) below the icon () indicates the parallel group ID no. (former) and the parallel ID no. (latter).</p> <p> NOTE: On the master UPS's screen, you can check its status and readings as well as the slave UPS's partial status and readings. On a slave UPS's screen, you can only check its own status and readings.</p>
2		✓			Tap the button to open the measurement menu. For the menu items, refer to <i>Figure 7-1</i> .
3		✓			Tap the button to open the setup menu. For the menu items, refer to <i>Figure 7-1</i> . For details, refer to <i>7.6 UPS Settings</i> .
4		✓			Tap the button to open the maintenance menu. For the menu items, refer to <i>Figure 7-1</i> . For details, refer to <i>7.7 System Maintenance</i> .
5		✓		✓	It indicates User login status. Tap the icon to change the login permission. Please refer to <i>7.4 Password Entry</i> .
		✓		✓	It indicates Administrator login status. Tap the icon to change the login permission. Please refer to <i>7.4 Password Entry</i> .

No.	Icon/ Text	Button Function (Yes or No)	Text/ Digital Display (Yes or No)	Symbol Display (Yes or No)	Description
6		✓		✓	<ol style="list-style-type: none"> Historical event screen shortcut button (). When the icon is blue (), it means there is no warning event.
		✓	✓	✓	<ol style="list-style-type: none"> Warning screen shortcut button () & buzzer icon (). When the icon is red (), it indicates that there is a warning event. At this time, the buzzer will sound and the buzzer icon will appear in red (). The numerical value at the upper right of the icon () indicates the total number of the warning events. To mute the buzzer, tap the icon (), and the icon will become gray (). If there is any new warning event happening afterwards, the buzzer will sound and the icon () will appear and light up again.
7	10:30 Jun 24,2025		✓		It indicates the time and date.
8	On-Line ECO Green Clean Frequency Conversion Bypass Battery Standby Softstart Energy Recycle		✓		It indicates the UPS's current operation mode.
9		✓			Tap the button to check the power flow diagram and the operation status of the UPS.
10		✓			Tap the button to check the Input , Output , and Battery summary status of the UPS.

No.	Icon/ Text	Button Function (Yes or No)	Text/ Digital Display (Yes or No)	Symbol Display (Yes or No)	Description
11		✓			Tap the button to check the system status.
12		✓			Tap the button to check the EMS status. To enable the function, you have to connect an optional EMS 1000 (EnviroProbe) to the UPS and complete relevant settings. For details, refer to 8. Optional Accessories .
13		✓		✓	ON/ OFF Button. The gray icon (⏻) indicates that the inverter is OFF. The green icon (⏻) indicates that the power-on process is completed and the inverter is ON.
14		✓		✓	1. It indicates bypass input status (Green: Normal/ Red: Abnormal or OFF). 2. Bypass input screen shortcut button.
15		✓		✓	1. It indicates main input status (Green: Normal/ Red: Abnormal or OFF). 2. Main input screen shortcut button.



No.	Icon/ Text	Button Function (Yes or No)	Text/ Digital Display (Yes or No)	Symbol Display (Yes or No)	Description
16		✓	✓	✓	<ol style="list-style-type: none"> 1. It indicates battery status (Green: Normal/ Flashing Green & Gray: Battery Mode/ Flashing Red & Gray: Battery Not Connected). 2. It shows battery remaining capacity (%) and battery remaining time (minutes). 3. Battery status screen shortcut button.
17				✓	It indicates bypass static switch status (Green: ON/ Gray: Abnormal or OFF).
18				✓	It indicates rectifier status (Green: Normal/ Gray: Waiting or OFF).
19		✓		✓	<ol style="list-style-type: none"> 1. It indicates inverter status (Green: Normal/ Gray: Waiting or OFF). 2. Inverter output screen shortcut button.
20				✓	It indicates converter status (Green: Normal/ Gray: Waiting or OFF).
21		✓	✓	✓	<ol style="list-style-type: none"> 1. It indicates output status (Green: Normal/ Gray: No Output). 2. It shows load capacity (%). 3. UPS output screen shortcut button.

Other icons on the touch panel are shown in the table below.



No.	Icon	Function
1		It goes to the top page.
2		It goes to the last page.
3		It moves up.
		
4		It moves down.
		
5		It goes to the previous page.
		
6		It goes to the next page.
		
7		Increase
8		Decrease
9		<ol style="list-style-type: none"> 1. It indicates the page no. 2. It goes to a specific page according to the no. you key in.
10		Delete
		
11		Capital
12		Space



NOTE:

1. After the backlight is turned off, you can tap the LCD to return to the **Main Screen**.
2. The sleep time for the backlight can be adjusted. Please go to  → **General Setting** → **Screen** → **Screen Sleep (after)**.
3. If you are logged in as **Administrator**, you will be logged out when the backlight is off. Tap to wake up the LCD screen, and it will go back to the **Main Screen** in the **User** login status. Even if you set up the backlight in 'Never Sleep' mode, you will still be logged out after the screen is idle for 5 minutes.
4. The default language is English, which differs according to countries. To change the display language, please go to  → **General Setting** → **User** → **Language**.

7.4 Password Entry

1. **Administrator** login requires a password while **User** login does not.
2. Tap  → enter the **Administrator** password (contact service personnel for the default password) → the icon  appears, indicating the **Administrator** login is successful.
3. To change the **Administrator** password, please go to  → **General Setting** → **User** → **Admin Password** (4 digits).



7.5 Check Kilowatt-Hour

Path:  → **UPS Output** → **kWh Icon** ()

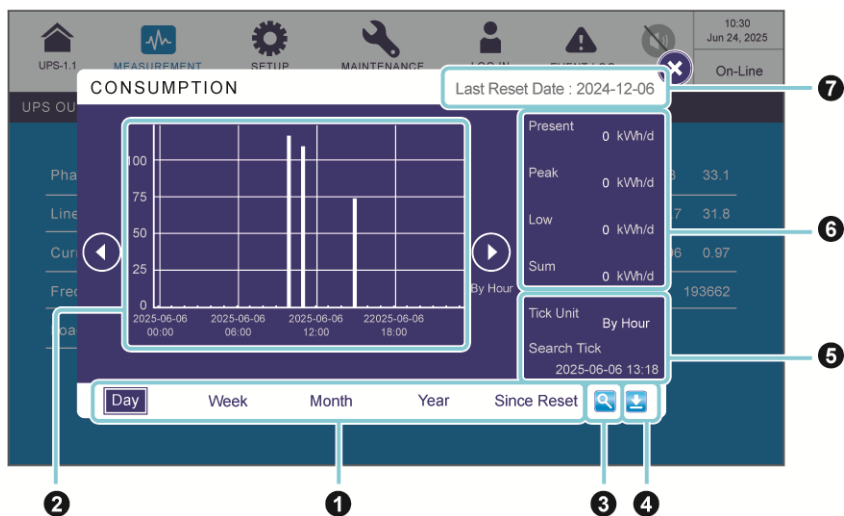
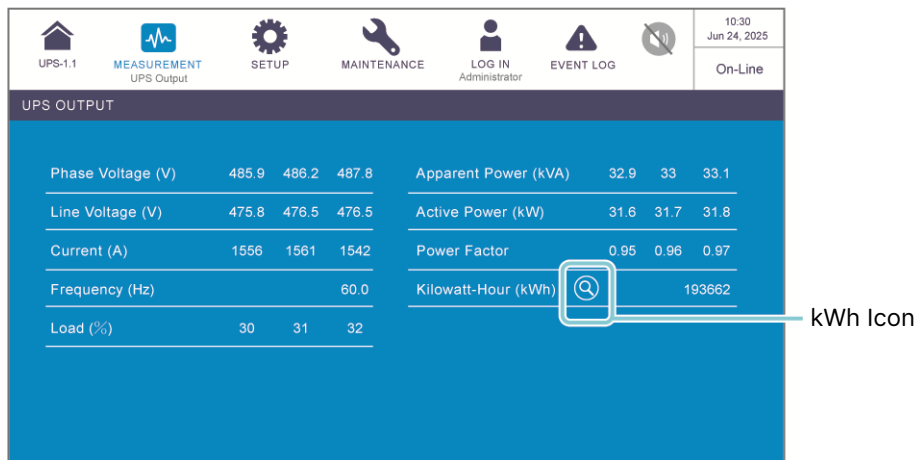
Tap the kWh icon () to check the **kWh statistics** of the UPS output in the following window.



No.	Item	Description
1	Sheet Tabs (Day/ Week/ Month/ Year/ Since Reset)	Tap the sheet tabs to view the kWh statistics and column charts of different time scales.
2	Column Chart	<ol style="list-style-type: none"> It shows the UPS's output kWh statistics, with time on X-axis and kWh on Y-axis. Tap the column on the chart, and the corresponding piece of data will appear below the chart.

No.	Item	Description
③	Search Tick Setup Icon	Tap () , and you can set the date and time for the 'Search Tick' to view the corresponding column chart.
④	Save	Click the icon () to download data to your USB drive.
⑤	Search Tick	It shows the date and time that has been set via () .
⑥	Present/ Peak/ Low/ Sum (kWh/d)	Regardless of different kWh statistics sheets, these four items only indicate today's statistics: the present value/ the highest value (so far)/ the lowest value (so far)/ the sum (so far).
⑦	Last Reset Date	The last date when 'Clear Kilowatt Hour' was executed.

7.6 UPS Settings

This chapter lists all the UPS setting items for your reference (not including the setting items for the optional accessories). Some items will show up only under certain conditions. Please refer to *7.1 LCD Display Hierarchy* for details.

7.6.1 Bypass Setting

Path:  → Bypass Setting

Item	Description
Bypass Frequency Range	Set up the bypass output's frequency range.
Bypass Voltage (Max)	Set up the bypass output's maximum voltage.
Bypass Voltage (Min)	Set up the bypass output's minimum voltage.
ECO Voltage Range (± %)	Set up the bypass output's voltage range in ECO mode.

7.6.2 Mode Setting

Path:  → Mode Setting

Item	Description
On-Line Mode	Set up the UPS in On-Line mode. In On-Line mode, it is the inverter to supply power to the connected loads.
Green Mode	Set up the UPS in Green mode. In Green mode, it is the inverter to supply power to the connected loads and the power modules take turn to rest according to the situation of total load capacity.
ECO Mode	Set up the UPS in ECO mode. In ECO mode, it is the bypass to supply power to the connected loads. It is suggested that you set the UPS in ECO mode only when there is stable main AC power. Otherwise, power supply quality will be compromised.
Energy Recycle Mode	Set up the UPS in Energy Recycle mode. Energy Recycle mode is only applicable to UPS self-test only. Without connection to any critical loads, the UPS can execute current test under full load condition.
Frequency Conversion Mode	<p>Set up the UPS in Frequency Conversion mode. In Frequency Conversion mode, it is the inverter to supply power to the connected loads with a fixed output frequency. Please note that the output will be terminated once the inverter is turned off.</p> <p> NOTE: Frequency Conversion mode is only applicable to single UPS but not to parallel UPSs.</p>
Clean Mode	Set up the UPS in Clean mode. In Clean mode, it is the bypass to supply power to the connected loads. After the UPS is manually set as Clean mode via the LCD, the system will automatically detect the output status to let the inverter provide active filter function to compensate harmonics and PF as well as reduce reactive current to improve overall power quality.

7.6.3 Input & Output Setting

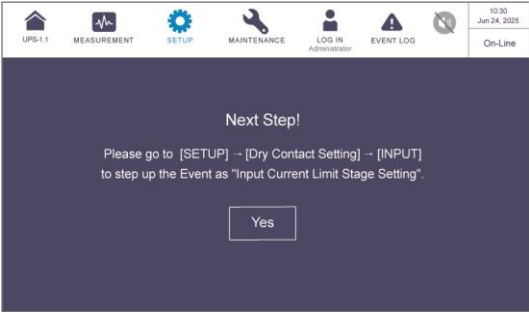

Path:  → Input & Output Setting



Item	Sub Item	Description
Input	System Sequential Start	Set up the time interval for the system to be transferred from Battery mode to On-Line mode. The setup will help the generator to handle the whole loads in a sequential manner to avoid generator shutdown due to sudden inrush current.
	Power Module Sequential Start	Set up the time interval for the power module to be transferred from Battery mode to On-Line mode. The setup will help the generator to handle the whole loads in a sequential manner to avoid generator shutdown due to sudden inrush current.
	Input Over Current Limit- Stage 1/ Stage 2	<p>Set up which stage's current should be applied to the input over current limit. There are two selections, Default and Switch By Dry Contact. If you choose Default, the stage 1's current will be applied. If you choose Switch By Dry Contact, the following window will pop up to ask you to set up an input dry contact's event as 'Input Current Limit Stage Setting'.</p> 

Item	Sub Item	Description
Input (continued)	Input Over Current Limit- Stage 1/ Stage 2	<p>After setup, the system will follow the dry contact's status (normally-open or normally-closed) to decide whether stage 1 or stage 2's current should be applied.</p> <p>Please note that the input dry contacts must be connected first (please refer to 4.1.10 Input Dry Contacts) before you set up stage 1 and stage 2's current, and only when you choose Switch By Dry Contact can the stage 2' current be set up. The current value should be set from 946 Ampere to 1419 Ampere.</p>
Output	Voltage	Set up the output voltage.
	Voltage Compensation	When the UPS is distant from the loads and there is a voltage drop in the output, you can adjust the INV output voltage amplitude for voltage compensation.
	Frequency	Set up the output frequency as 50Hz (default) or 60Hz. The system will automatically select the output frequency in accordance with the bypass power.
	Slew Rate	Set up the maximum permissible speed for the system output frequency to catch up with the bypass frequency variation.
	PM Redundancy	Set up how many power modules that need to be preserved for redundancy.
	Async Transfer Time	When (1) the inverter is not synchronized with the bypass and (2) the loads need to be transferred to the bypass source, there will be an interrupted transfer time according to this setup value.

7.6.4 Battery & Charging Setting

Path:  → Battery & Charging Setting

Item	Description
<p style="text-align: center;">Battery Type</p>	<p>Set up the battery type as VRLA/ LiB (Dry Contact)*1/ LiB (Integration)*2.</p> <p> NOTE:</p> <ol style="list-style-type: none"> *1 If you use non-Delta lithium-ion batteries, please set up the battery type as 'LiB (Dry Contact)'. Please refer to 4.1.10 Input Dry Contacts and 7.6.6 Dry Contact Setting. For more information about configurations of the lithium-ion batteries, please contact Delta customer service. *2 If you use the Delta lithium-ion batteries, please set up the battery type as 'LiB (Integration)'. The item 'LiB (Integration)' will only appear on the LCD if you use the Delta lithium-ion batteries with the optional multifunctional communication card (MFC) being installed in the SMART slot. Please contact Delta customer service if you need more information.
<p>Battery Rating Voltage</p>	<p>Set up the battery rating voltage.</p>
<p>Battery Strings</p>	<p>Set up how many battery strings that are used on site.</p>
<p>Battery Low Warning</p>	<p>Set up the battery low warning voltage.</p>
<p style="text-align: center;">Battery Cut Off Voltage</p>	<p>Set up the battery low voltage. In Battery mode, when the battery low voltage is reached, the battery power will be cut off, and inverter of the UPS will shut down. The loads will then be transferred to bypass if the bypass is available; otherwise, the UPS will shut down.</p>
<p>Capacity</p>	<p>Set up the battery capacity.</p>
<p>Float Charge Voltage</p>	<p>Set up the float charge voltage.</p>
<p style="text-align: center;">Equalized Charge Voltage</p>	<p>Set up the equalized charge voltage.</p> <p> NOTE:</p> <p>The item will only show up if the Battery Type is set as 'VRLA'.</p>

Item	Description
Restored Voltage	Set up the restored voltage.  NOTE: <ol style="list-style-type: none"> The item will only show up if the Battery Type is set as 'LiB (Integration)'. When the remaining battery voltage reaches the setup restored voltage, the UPS will automatically activate the charger to re-charge the batteries. If the Battery Type is set as 'LiB (Dry Contact)', the item will not show up.
Charge Current (Max)	Set up the maximum charge current.
Auto Equalized Charge	Enable or disable the auto-equalized charge.
Auto Equalized Charge Interval	Set up the auto equalized charge interval.
Equalized Charge Time	Set up the equalized charge time.
Reduce Charging While on DG	Set up the charging current limit. The charging current will be limited on this value when the generator is turned on.  NOTE: This setup item will only appear after you select  → Dry Contact Setting → Input → Event → Generator Status .
Battery Test Fail Voltage	Set up the battery test fail voltage. When the battery voltage is under the test fail voltage, it means battery fail.
Battery Test Duration	Set up how long the battery test should last.
Auto Battery Test Interval	Set up the battery test interval.
Low Temperature Alarm	Enable or disable the low temperature alarm. If enabled, set up the temperature.
High Temperature Alarm	Enable or disable the high temperature alarm. If enabled, set up the temperature.
Installation Date	Record the battery installation date.

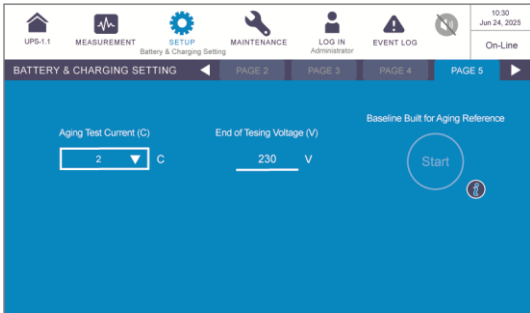
Item	Description
Next Replacement Date	Set up the battery replacement date.
Aging Test Current (C)	Set up the battery discharge current of the battery aging test.
End of Testing Voltage (V)	Set up the battery end of testing voltage for the battery aging test. When the battery voltage is reached, UPS will stop the battery aging test and establish the battery discharging curve.
<p>Baseline Built for Aging Reference</p>	<p>Establish the battery discharging curve as the benchmark and reference for battery aging test. It is suggested that you establish the reference right after initial installation of batteries. Please refer to below for more information.</p> <p>1. If you cannot tap the  on the LCD, an information icon will show on the LCD. Tap the icon to learn the possible reasons. Possible reasons include:</p> <ol style="list-style-type: none"> Battery Constant Current Discharging Test is under processing. Battery status doesn't meet the testing conditions. Load status doesn't meet the testing conditions. Utility status doesn't meet the testing conditions. Please check if every UPS has any alarm. 

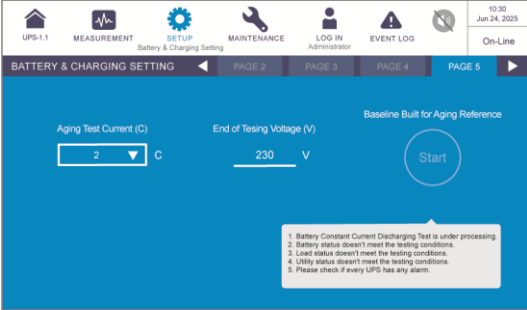
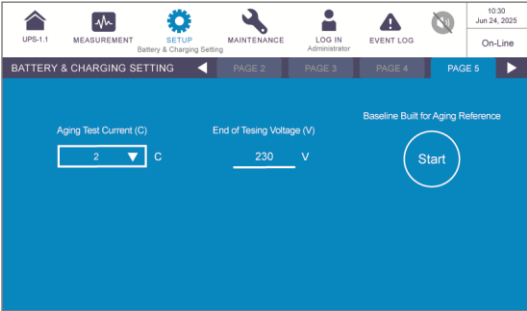
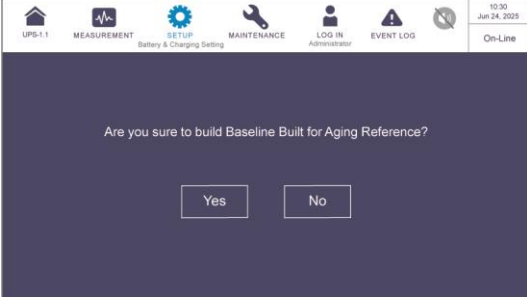
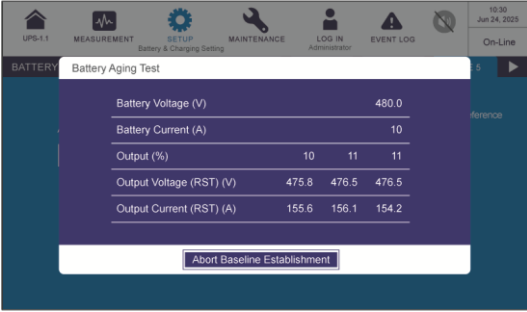
Item	Description
<p>Baseline Built for Aging Reference (continued)</p>	 <p>2. After the Aging Test Current and End of Testing Voltage are set, press the start button under Baseline Built for Aging Reference.</p>
	
	
<p>(1) After you tap yes to build the Baseline for Aging Reference, the following screen will pop up and ask you if you want to abort baseline establishment.</p> 	

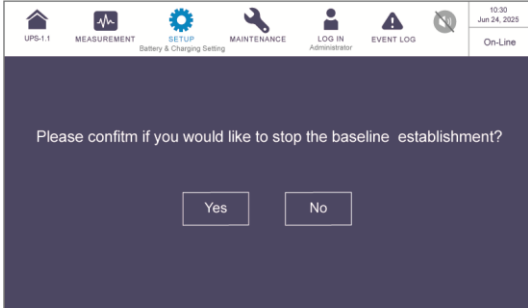
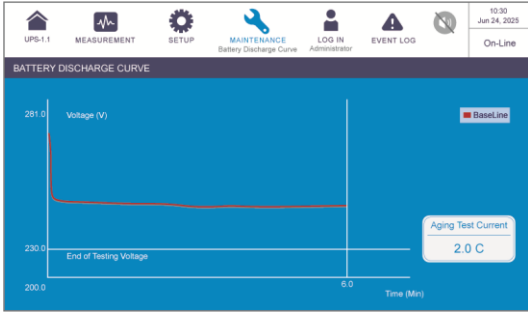
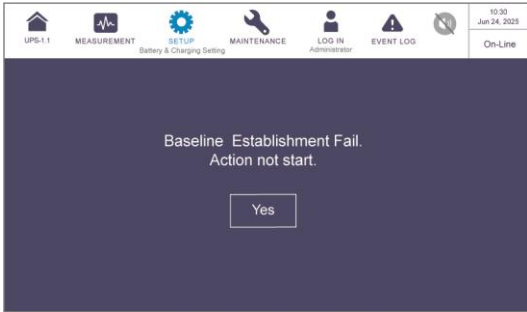
Item	Description
<p style="text-align: center;">Baseline Built for Aging Reference (continued)</p>	<p>(2) Click Abort Baseline Establishment and the following screen will pop up to ask if you would like to stop the baseline establishment.</p> 
	<p>(3) If you select 'NO', the test will continue. (4) When the test is successful, the battery discharging curve (baseline) will appear as follows.</p>
	
	<p>When the test is failed, the following screen will pop up. Click 'YES' to go back to the original screen and contact service personnel for failure reasons.</p> 

7.6.5 Parallel Setting

Path:  → Parallel Setting

Item	Description
Parallel Group ID	The UPSs in parallel connection must be assigned the same parallel group ID no. in order to let the outputs of the parallel UPSs be put in parallel connection and let the loads be evenly distributed among the parallel units. If the parallel UPSs have different parallel group ID no., their output signals might be synchronized but their outputs cannot be connected in parallel.
Parallel ID	The UPSs that need to be paralleled must be assigned the same parallel group ID no. and different parallel ID no. in order to let the parallel function work.
Common Battery	If the parallel UPSs that have the same parallel group ID no. need to share common batteries, please select ' Enable ' for the ' Common Battery ' setup item. Otherwise, the function of battery abnormality detection will fail. For more information about common battery, please refer to <i>5.5 External Battery Cabinet Connection Warnings</i> .

7.6.6 Dry Contact Setting

Path:  → Dry Contact Setting

Input Dry Contact No.	Event Selection	Type
Input Dry Contact 1 Input Dry Contact 2 Input Dry Contact 3 Input Dry Contact 4 Input Dry Contact 5 Input Dry Contact 6	1. None 2. Generator Status 3. Battery Ground Fail 4. External Battery Fuse Open 5. Active Standby 6. Battery Abnormal Shutdown 7. Input Transformer OTW 8. Output Transformer OTW 9. Charger Off 10. Major Battery Abnormal Alarm	Set up NO (normally open) or NC (normally closed) for each input dry contact.



Input Dry Contact No.	Event Selection	Type
Input Dry Contact 1 Input Dry Contact 2 Input Dry Contact 3 Input Dry Contact 4 Input Dry Contact 5 Input Dry Contact 6 (continued)	11. Minor Battery Abnormal Alarm 12. Force Battery Mode 13. External Battery Breaker Detection 14. Force Sync External Source 15. Input Current Limit Stage Setting	Set up NO (normally open) or NC (normally closed) for each input dry contact.
Output Dry Contact 1 Output Dry Contact 2 Output Dry Contact 3 Output Dry Contact 4 Output Dry Contact 5 Output Dry Contact 6	1. None 2. Load On Inverter 3. Load On Bypass 4. Load On Battery 5. Battery Low 6. Battery Input Abnormal 7. Battery Test Fail 8. Internal Comm. Fail 9. External Parallel Comm. Fail (only applicable to parallel application) 10. Output Overload/ Warning Shutdown 11. EPO Activated 12. Load On Manual Bypass 13. Battery Over Temperature 14. Output Voltage Abnormal 15. Battery Need Replacement 16. Bypass Over Temperature 17. Bypass Static Switch Fault 18. UPS Over Temperature 19. Battery Breaker Shunt Trip 20. Backfeed Protection 21. General Alarm 22. Main Input Abnormal 23. Input Neutral Disconnect 24. PFC General Alarm 25. INV General Alarm	Set up NO (normally open) or NC (normally closed) for each output dry contact.

Input Dry Contact No.	Event Selection	Type
Output Dry Contact 1	26. Fan Failure Alarm	Set up NO (normally open) or NC (normally closed) for each output dry contact.
Output Dry Contact 2	27.Main Input Switch Open	
Output Dry Contact 3	28.Bypass Input Switch Open	
Output Dry Contact 4	29.Output Switch Open	
Output Dry Contact 5	30.Battery Switch Open	
Output Dry Contact 6	31.Battery Disconnect	
(continued)	32.Battery Abnormal Alarm - BMS 33.INV Failure Shutdown 34.Battery Low Shutdown	

7.6.7 General Setting

Path:  → General Setting

Item	Sub Item	Description
DATE/ TIME	Date Format	Select the date format.
	System Time	Set up the system time manually or automatically. Manual: Manually set the time and date. SNTP: Automatically synchronize with SNTP servers.
	Date	Set up the date.
	Time	Set up the time.
SCREEN	Screen Brightness	Adjust the LCD display brightness (default: 80).
	Screen Sleep (after)	Set up the LCD backlight sleep time (default: 1 minute).
USER	Language	Set up the display language (default: English).
	Temperature Unit	Set up the temperature unit to be displayed in °F or °C.
	MODBUS ID	Set up the MODBUS ID for the MODBUS port located at the rear of the touch panel.
	Baud Rate	Set up the baud rate for the MODBUS port located at the rear of the touch panel.

Item	Sub Item	Description
USER (continued)	On/ Off Button Access	Set up the access for the ON/ OFF Button (🔌) as 'Any User' or 'Administrator Only'.
DUST FILTER	Dust Filter Installation	If you have installed any dust filter, please select ' Enable '; if not, please select ' Disable '.
	Dust Filter Installation Date	Set up the dust filter installation date.  NOTE: Only when you select ' Enable ' for ' Dust Filter Installation ' can you set up the item.
	Dust Filter Replacement Date	Set up the dust filter replacement date. When the date is due, the red warning icon (⚠️) will automatically appear in the upper right corner of the LCD, and the alarm message ' Replace Dust Filter ' will be displayed.  NOTE: Only when you select ' Enable ' for ' Dust Filter Installation ' can you set up the item.

7.6.8 Net Setting

Path:  → Net Setting

Item	Sub Item	Description
HOST	Host Name	Set up the host name. Length: 16 characters max.
	System Contact	Set up the contact person. Length: 32 characters max.
	System Location	Set up the equipment location. Length: 32 characters max.
	MAC Address	Set up the MAC address of the network interface. It is displayed as six groups of two hexadecimal digits and separated by hyphens.

Item		Sub Item	Description
IPV4	Current Status	DHCP Client	Current DHCP State.
		IP Address	Current IPv4 address.
		Subnet Mask	Current subnet mask address.
		Gateway IP	Current gateway IP address.
		DNS 1 IP	Current DNS server 1's IP address, which can be updated by DHCP.
		DNS 2 IP	Current DNS server 2's IP address, which can be updated by DHCP.
		Search Domain	Current domain. Length: 32 characters max.
	Setting	DHCP Client	Enable or disable DHCP client to obtain the IPv4 address.
		IP Address	Set up the static IPv4 address.
		Subnet Mask	Set up the static IPv4 subnet mask.
		Gateway IP	Set up the IPv4 gateway IP address.
		DNS 1 IP	Set up the DNS server 1's IP address.
		DNS 2 IP	Set up the DNS server 2's IP address.
	Search Domain	Set up the search domain. Length: 32 characters max.	
IPV6	Current Status	LLA	Current link local address.
		DHCPv6	Current DHCPv6 state.
		DNS 1 IP	Current DNS server 1's IP address, which can be updated by DHCP.
		DNS 2 IP	Current DNS server 2's IP address, which can be updated by DHCP.
		Search Domain	Current IPv6 domain address. Length: 32 characters max.
		IP Address	Current IPv6 address.
		Route Entries #	Current route's destination and gateway.

Item		Sub Item	Description
IPV6 (continued)	Setting	DHCP Client	Enable or disable DHCP client to obtain the IPv6 address.
		IP Address	Set up the static IPv6 address.
		Prefix	Set up the static IPv6 prefix length. Length: 1 ~ 128 bits.
		Gateway IP	Set up the IPv6 gateway IP address.
		DNS 1 IP	Set up the DNS server 1's IP address.
		DNS 2 IP	Set up the DNS server 2's IP address.
		Search Domain	Set up the search domain. Length: 32 characters max.
WEB	HTTP	Enable or disable HTTP.	
	HTTPS	Enable or disable HTTPS.	
	HTTPS Port	Set up the HTTPS port No.	
	SSL Certificate	Upload the SSL certification.	
REMOTE USER	Privilege	There are three levels, Administrator, Device Manager and User.	
	Account Name	Set up the Administrator, Device Manager or User's account name.	
	Password	Set up the Administrator, Device Manager or User's password.	
	Login Limitation	Set up the Administrator, Device Manager or User's login limitation.	
SNTP	Time Zone	Select the time zone.	
	Primary Time Server	Set up the primary NTP server.	
	Secondary Time Server	Set up the secondary NTP server.	
	Period Time	Set up how long the system will automatically synchronize the time with servers.	

Item	Sub Item	Description
DAYLIGHT SAVING	Daylight Saving	Enable or disable the daylight saving function.
	Daylight Saving From	Set up the daylight saving beginning time.
	Daylight Saving To	Set up the daylight saving ending time.
SNMP	SNMP	Enable or disable the SNMP function.
	SNMP Server Port	Set up the SNMP server port No.
	Context Name	Define the context name.
	SNMP MIB Download	Download MIB files.
NMS	NMS IP	Set up the NMS IP address that allows connection.
	IP Prefix	Set up the NMS IP mask address that allows connection.
	Community String	Set up the community string.
	Access Level	Set up the access level for each source IP.
SNMPV3 USM	User Name	Set up the SNMPv3 user name.
	Method	Select the encryption method.
	AuthPhrase	Set up the authentication password.
	PrivPhrase	Set up the privacy password.
	Access Level	Set up the access level for each SNMPv3 user.
MODBUS TCP	MODBUS TCP	Enable or disable the MODBUS TCP function.
	Slave ID	Set up the slave ID No.
	Port	Set up the MODBUS TCP port No.
	MODBUS TCP Address Table	Download the MODBUS TCP address table.

Item	Sub Item	Description
MODBUS TCP IP LIST	Allowed Remote IP	Set up the allowed remote IP.
	Access Level	Set up the access level for each remote IP.

7.6.9 Net Notification

Path:  → Net Notification

Item	Sub Item	Description
SNMP TRAP LIST	Target IP	Set up the target IP.
	Port	Set up the target IP's port No.
	Trap Type	Select the trap type.
	Community String	Set up the community string.
	Event Level	Select the event level.
	SNMPv3 User Name	Select the SNMPv3 user name.
	MIB	Select the MIB type.
INFORM	Timeout	Set up the timeout for SNMP INFORM.
	Retry	Set up the retry times for SNMP INFORM.
MAIL SERVER	SMTP Server Name or IP	Set up the SMTP server's DNS IP.
	SMTP Server Port	Set up the SMTP server's port No.
	Sender	Set up the sender's email address.
	Account	Set up the sender's email login account.
	Password	Set up the sender's email login password.
	TLS	Enable or disable the TLS function.

Item	Sub Item	Description
MAIL LIST	Receiver	Set up the receivers' email address.
	Event Level	Select the event level. If the event's level is higher than this setting, this event log will be sent.
	Email Test	Test if the sample event log will be sent or not.

7.6.10 Control



Path:  → Control

Item	Description
Buzzer	Enable or disable the buzzer.
Reset Module	Reset the power modules or not. In Bypass mode, when you tap the ON/ OFF Button (⏻) to start up the UPS but the UPS does not respond, please select ' Reset ' to reset the power modules. After the power modules are reset, please tap the ON/ OFF Button (⏻) to start up the UPS.
Reset System	Reset the system or not. In Bypass mode, when you tap the ON/ OFF Button (⏻) to start up the UPS but the UPS does not respond, please select ' Reset ' to reset the system. After the system is reset, please tap the ON/ OFF Button (⏻) to start up the UPS.
Force Equalized Charge	Manually force the UPS to run in auto equalized charge mode to charge the batteries.
Force Bypass to Inverter	Manually force the UPS to switch from bypass to inverter when the inverter keeps staying in the soft-start status and is unable to transfer to On-Line mode successfully.

7.7 System Maintenance

7.7.1 Warning

Path 1:  → Warning

Path 2: When there is a warning, the buzzer icon () will light up in red, and the buzzer will sound. Tap the warning icon () to enter the **WARNING** screen.

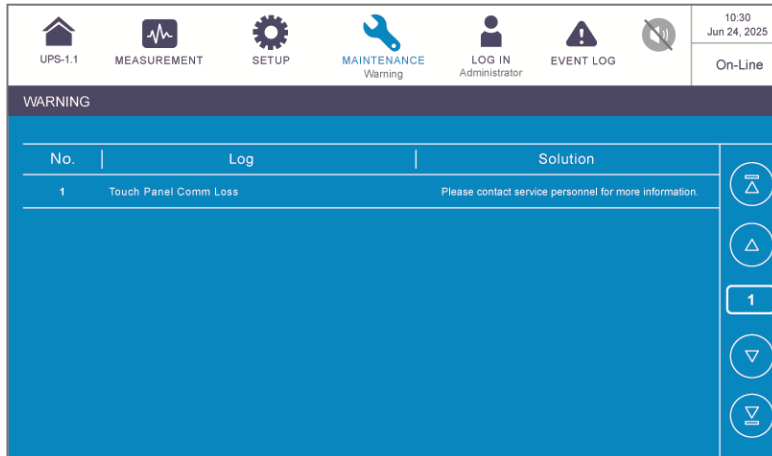

7.7.2 Historical Event

Path:  → Historical Event

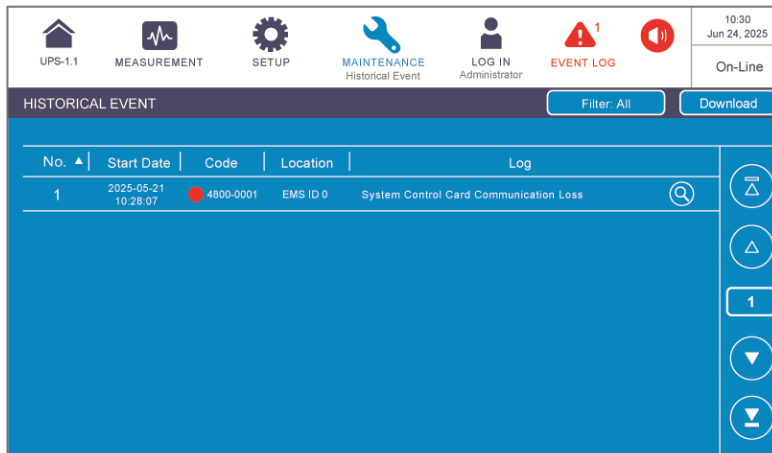

7.7.3 Statistics

Path:  → Statistics
MAINTENANCE

Item	Description
In Battery Mode (times/ hours)	It shows how many times the UPS runs in Battery mode.
In Bypass Mode (times/ hours)	It shows how many times the UPS runs in Bypass mode.
Operation Time	It shows how long the UPS has operated.

To clear the statistics, please refer to **7.7.6 Clear**.

7.7.4 Test

Path:  → Test
MAINTENANCE

You can perform a manual battery test and battery aging test via the LCD screen.

7.7.5 Battery Discharge Curve

Path:  → Battery Discharge Curve
MAINTENANCE

For relevant information, please refer to **Baseline Built for Aging Reference** stated in **7.6.4 Battery & Charging Setting**.

7.7.6 Clear

Path:  → Clear
MAINTENANCE

Item	Description
Clear Statistics	After you select ' Clear ' and confirm clearance of statistics, all records of the statistics will be cleared.
Clear Historical Event	After you select ' Clear ' and confirm clearance of historical event logs, all historical event logs will be cleared.
Clear Battery Test Result	After you select ' Clear ' and confirm clearance of battery test result, the battery test result will be cleared.
Clear Kilowatt Hour (kWh)	After you select ' Clear ' and confirm clearance of kilowatt hour records, the kilowatt hour statistics will be cleared.

Item	Description
Clear Battery Discharge Curve	After you select ' Clear ' and confirm clearance of battery discharge curve, the battery discharge curve will be cleared.



NOTE:

The records mentioned above are important information for system analysis and maintenance. Do not clear any of them without the consent of qualified service personnel.

7.7.7 Advanced Diagnosis

Path:  MAINTENANCE → **Advanced Diagnosis**

This is an optional function. Please contact Delta customer service for more information. If you are able to access to the **Advanced Diagnosis** screen, you can obtain the system and the specific power module's relevant readings of the following items.

Location	System	Power Module #
Item	Ambient Temp. (°C)	PFC Temp. (°C)
	STS Temp. (°C)	Input Choke Temp. (°C)
	Battery Temp. (°C)	Charger Temp. (°C)
	STS Module Fan Speed (rpm)	Aux Temp (°C)
	Top Venting Fan Speed (rpm)	INV Temp. (°C)
	-	INV Cap Temp. (°C)
	-	Fan Speed (rpm)

7.7.8 Version & S/N



NOTE:

To operate the UPSs in parallel, please make sure all the versions below are the same for each parallel unit. If you have any questions about parallel operation, please contact Delta customer service.

Path:  MAINTENANCE → Version & S/N

Item	Sub Item	Description
S/N	System	Check the system's serial no.
	Touch Panel	Check the touch panel's serial no.
	Power Module #	Check a specific power module's serial no.
MAIN	Parallel Communication Card #_ MCU/ FPGA	Check and update the MCU or FPGA firmware version of a specific parallel communication card.
	System Control Card_ MCU/ FPGA	Check and update the MCU or FPGA firmware version of the system control card.
	Multi-function Unit_ MCU/ FPGA	Check and update the MCU or FPGA firmware version of the multi-function unit card.
	Touch Panel _ MCU	Check and update the touch panel's MCU firmware version.
STS	STS Module- R_ MCU/ FPGA	Check and update the MCU or FPGA firmware version of the STS module- R.
	STS Module- S_ MCU/ FPGA	Check and update the MCU or FPGA firmware version of the STS module- S.
	STS Module- T_ MCU/ FPGA	Check and update the MCU or FPGA firmware version of the STS module- T.
INV	PM #_ MCU1/ MCU2/ FPGA	Check and update the MCU1, MCU2 or FPGA firmware version of a specific power module's inverter.
PFC	PM #_ MCU1/ MCU2/ FPGA	Check and update the MCU1, MCU2 or FPGA firmware version of a specific power module's PFC.

Chapter 8 : Optional Accessories

No.	Item	Function
1	Dust Filter	It prevents dust from entering into the UPS to ensure UPS reliability and to prolong product life.
2	EMS 1000 (EnviroProbe)	It monitors temperature, humidity and other connected monitoring devices in a room environment. Connect the EMS 1000 (EnviroProbe) to the UPS's EMS port located at the rear of the touch panel, and the UPS will integrate the detected information from the EMS 1000 (EnviroProbe) and display relevant data on the LCD. See Figure 4-22 for the location of the EMS port. For details, please refer to 8.1 EMS Function on the LCD Screen .
3	Battery Cabinet Temperature Sensor Cable	It detects the temperature of an external battery cabinet connected to the UPS.
4	Parallel Cable (Length: 20 m (787.4"))	It connects to the parallel UPSs.
5	Multifunctional Communication Card (MFC)	<p>If you use the Delta lithium-ion batteries, you must purchase and install the multifunctional communication card (MFC) in the SMART slot shown in Figure 4-1 to monitor the battery status via the UPS's LCD. For relevant information, please refer to 8.2 MFC Function on the LCD Screen. Please contact Delta customer service if you need more information.</p> <p> NOTE: For parallel UPSs, you must install one multifunctional communication card (MFC) in each parallel UPS if you use the Delta lithium-ion batteries.</p>
6	Synchronized Multiple Bus (SMB) Cable (Length: 20 m (787.4"))	It connects to the UPS's SMB port.
7	Power Module Slot Cover	It covers the slot where no power module is installed.

**NOTE:**

For installation and operation details, please refer to the *Quick Guide* or *User Manual* included in the package of the optional accessory. To purchase any accessory mentioned above, please contact your local dealer or customer service.

8.1 EMS Function on the LCD Screen

- Path 1: Tap the shortcut button () on the Main Screen.

Path 2:  → EMS

The UPS can display the information of the optional EMS 1000 (EnviroProbe) on the EMS screen. To activate it, please connect the EMS 1000 (EnviroProbe) with the UPS and complete relevant settings.

**NOTE:**

1. The EMS screen is related to the settings shown in  → EMS Setting. The settings can be adjusted according to your needs.
2. For installation of the optional EMS 1000 (EnviroProbe), please refer to the instructions below and the *EnviroProbe 1000 Quick Guide* included in its package.

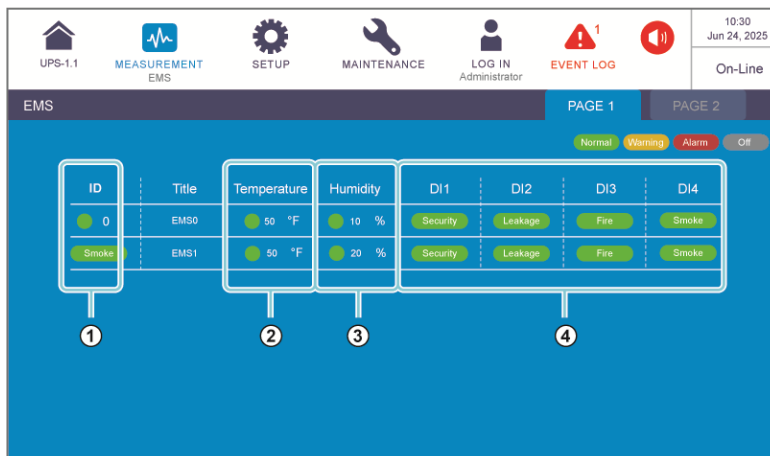

No.	Item	Color (Status)	Descriptions
①	ID	Green (Normal) Yellow (Warning) Red (Alarm) Gray (Off)	<ol style="list-style-type: none"> ID # represents each EMS 1000 (EnviroProbe) device which is connected and set as 'Enable'. It shows the integrated status of each EMS 1000 (EnviroProbe) device. The integrated status is determined by the most severe status among Temperature (°C), Humidity (%) and DI1 ~ DI4.
②	Temperature	Green (Normal) Yellow (Warning) Red (Alarm)	<p>It shows the statuses of Temperature/ Humidity based on the EMS settings.</p> <ul style="list-style-type: none"> Green (Normal): lower than the set Warning value. Yellow (Warning): higher than the set Warning value, but lower than the set Alarm value. Red (Alarm): higher than the set Alarm value.
③	Humidity	Green (Normal) Yellow (Warning) Red (Alarm)	<ul style="list-style-type: none"> Red (Alarm): higher than the set Alarm value. <p>If Red (Alarm)/ Yellow (Warning) is triggered, the status will recover only when the detected value is lower than the Recovery value.</p>
④	DI1	Green (None/ Information) Yellow (Warning) Red (Alarm)	<ol style="list-style-type: none"> It shows the statuses of the input contacts. The Title, NO/ NC, and Event Type can be adjusted according to your needs.
	DI2		
	DI3		
	DI4		

- Connecting the Optional EMS 1000 (EnviroProbe)**

- Each UPS can be connected with a maximum of 16 EMS 1000 (EnviroProbe) devices in string to expand the environment monitoring range. A maximum of eight UPS units can be paralleled. Please use a CAT-5 cable (user-supplied & the cable length depends on the on-site application and environment) to connect the EMS 1000 (EnviroProbe) to the EMS port on the UPS. For the location of the EMS port, please see *Figure 4-22*.
- The UPS only supports RS485 communication. When installing the EMS 1000 (EnviroProbe), please set the device's communication mode as RS485 following *3-1 Comm DIP Switch Settings* of the *EnviroProbe 1000 Quick Guide*.

- When installing, please set the ID # by the four ID DIP switches on the left of the device following **3-2 ID DIP Switch Settings** of the *EnviroProbe 1000 Quick Guide*.



NOTE:

The ID # of each EMS 1000 (EnviroProbe) device connected to the UPS must be different so that the UPS can identify each device.

- To enable the EMS function, you have to set up relevant items on the LCD after connecting the optional EMS 1000 (EnviroProbe) to the UPS.

- Path:  → **EMS Setting (Administrator login is required)**

The screenshot shows the 'EMS SETTING' screen with the 'SENSOR' tab selected. At the top, there are navigation icons for UPS-1.1, MEASUREMENT, SETUP EMS Setting, MAINTENANCE, LOG IN Administrator, EVENT LOG, and a signal strength indicator. The top right corner shows the time '10:30' and date 'Jun 24, 2025', along with an 'On-Line' status indicator. Below the navigation bar, the 'ID' is set to '0', the 'Title' is 'EMS0', and the 'Status' is 'Enable'. The main area is divided into two sections: 'Temperature' and 'Humidity'. Each section has four rows of settings: Alarm, Recovery, Warning, and Recovery, with values and units (°F or %) displayed.

Temperature			Humidity		
Alarm >	104	°F	Alarm >	90	%
Recovery <	100	°F	Recovery <	85	%
Warning >	86	°F	Warning >	80	%
Recovery <	82	°F	Recovery <	75	%

The screenshot shows the 'EMS SETTING' screen with the 'INPUT CONTACT' tab selected. The navigation bar and top status information are the same as in the previous screenshot. Below the navigation bar, the 'ID' is '0', the 'Title' is 'EMS0', and the 'Status' is 'Enable'. The main area shows a table for 'Input Contact' settings with four rows, each with an 'Input Contact' number, a 'NO/NC' dropdown, a 'Title', and an 'Event Type' dropdown.

Input Contact	NO/NC	Title	Event Type
1	Normally Open	Security	Warning
2	Normally Open	Leakage	Warning
3	Normally Open	Fire	Warning
4	Normally Open	Smoke	Warning



NOTE:

The default values are shown in the figures above.

Item	Sub Item	Description
SENSOR	ID	<p>Set the ID # (ID 0/ ID 1/ .../ ID 15) according to the ID DIP switch setting of the EMS 1000 (EnviroProbe) device.</p>  <p>NOTE: If the ID # setting is wrong, the warning message 'The EMS 1000 ID # Communication Fail' will appear.</p>
	Title	Set the title for each EMS 1000 (EnviroProbe) device.
	Status	The status ' Enable/ Disable ' determines whether or not the LCD shows the information of the EMS 1000 (EnviroProbe) device (ID #) on the screen.
	Temperature	Set the temperature (°C) values for Alarm/ Warning/ Recovery.
	Humidity	Set the humidity (%) values for Alarm/ Warning/ Recovery.
INPUT CONTACT	Input Contact 1	<ol style="list-style-type: none"> 1. Set each input contact as Normally Open (NO)/ Normally Closed (NC). 2. Set the title for each input contact. 3. Set the event type as None/ Information/ Warning/ Alarm.
	Input Contact 2	
	Input Contact 3	
	Input Contact 4	

8.2 MFC Function on the LCD Screen

The **PAGE 3 & MFC** screens (see the figures below) will only appear on the LCD if you use the Delta lithium-ion batteries with the optional multifunctional communication (MFC) card being installed in the SMART slot (see *Figure 4-1*). Please contact Delta customer service if you need more information.

- Path:  → **Battery Status**

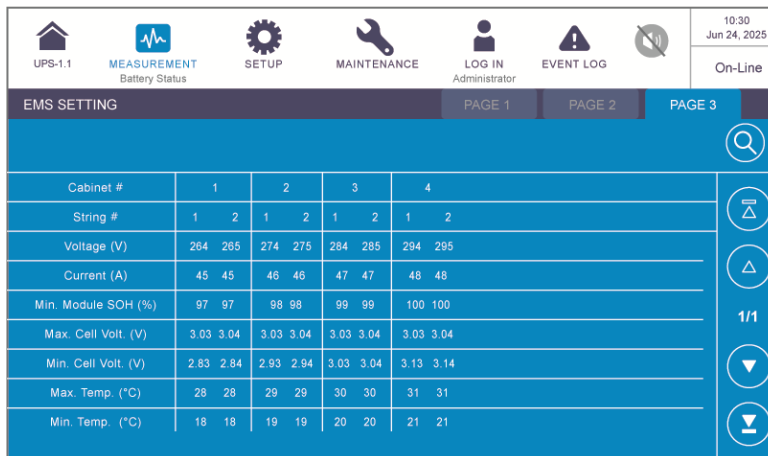

Cabinet #	1		2		3		4	
String #	1	2	1	2	1	2	1	2
Voltage (V)	264	265	274	275	284	285	294	295
Current (A)	45	45	46	46	47	47	48	48
Min. Module SOH (%)	97	97	98	98	99	99	100	100
Max. Cell Volt. (V)	3.03	3.04	3.03	3.04	3.03	3.04	3.03	3.04
Min. Cell Volt. (V)	2.83	2.84	2.93	2.94	3.03	3.04	3.13	3.14
Max. Temp. (°C)	28	28	29	29	30	30	31	31
Min. Temp. (°C)	18	18	19	19	20	20	21	21

In the screen shown above, you can view the corresponding battery cabinet's **String Voltage**, **String Current**, **Min. Module SOH (State of Health)**, **Max. Cell Volt.**, **Min. Cell Volt.**, **Max. Temp** and **Min. Temp**.

- Path:  → **General Setting (Administrator login is required)**

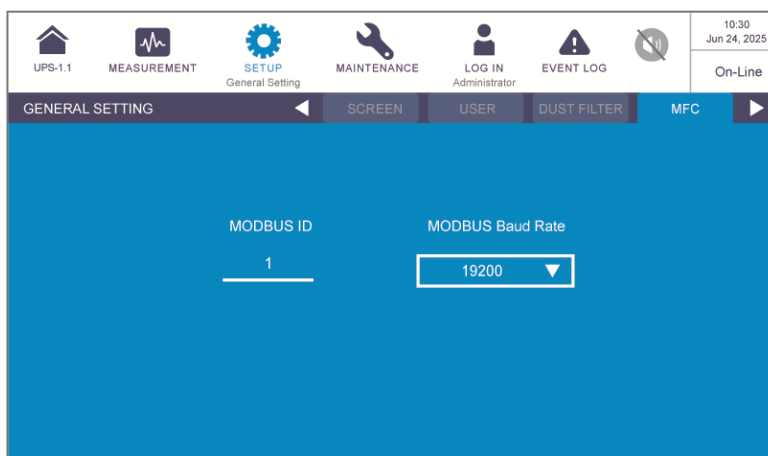

GENERAL SETTING	SCREEN	USER	DUST FILTER	MFC
MODBUS ID	MODBUS Baud Rate			
1	19200			

Item	Sub Item	Description
MFC	MODBUS ID	Set up the MODBUS ID for the optional multifunctional communication card (MFC).
	MODBUS Baud Rate	Set up the MODBUS baud rate for the optional multifunctional communication card (MFC).

- Path:  MAINTENANCE → Version & S/N

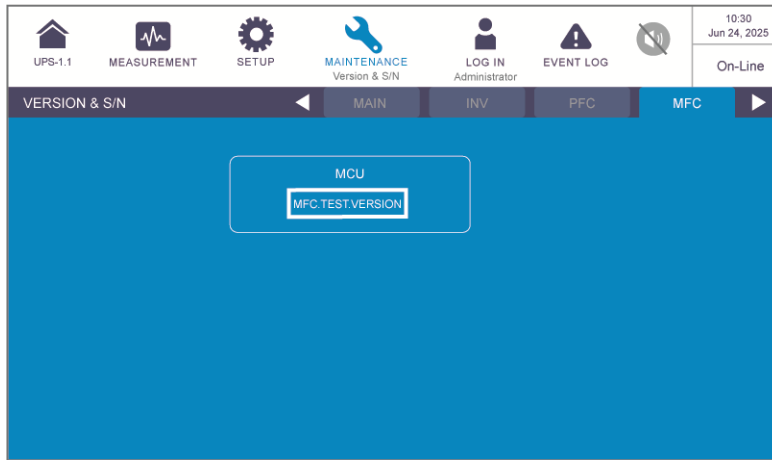

Item	Sub Item	Description
MFC	MCU	Check and update the MCU firmware version of the optional multifunctional communication card (MFC).

Chapter 9 : Maintenance



NOTE:

Please ask your local dealer or customer service for more maintenance information. Do not perform maintenance if you are not trained for it.

- **UPS**

1. UPS Cleaning:

Regularly clean the UPS, especially the slits, openings and filters, to ensure that the air freely flows into the UPS to avoid overheating. If necessary, use an air blower to clean the slits and openings and replace the filters regularly to prevent any object from blocking or covering these areas.

2. UPS Regular Inspection:

- a. Monthly check the filters and regularly replace them.

- b. Biannually check the UPS and inspect:

- 1) Whether the UPS, LED indicators and alarm function normally.

- 2) Whether the UPS works in Bypass mode (normally, the UPS works in On-Line mode). If yes, check if any error, overload, internal fault, etc. occur.

- 3) Whether the battery voltage is normal. If the battery voltage is too high or too low, find the root cause.

- **Batteries**

The UPS uses the lead-acid batteries or lithium-ion batteries. Make sure to replace the batteries according to the battery life. The actual battery life depends on the environment temperature, usage, and charging/ discharging frequency. High temperature environments and high charging/ discharging frequency will quickly shorten the battery life; thus, battery inspection and maintenance are required periodically. Please follow the suggestions below to ensure the normal battery life.

1. Keep usage temperature at 15 ~ 25°C (59 ~ 77°F).

2. When the UPS needs to be stored for an extended period of time, the lead-acid batteries must be recharged once every three months and the charging time must not be less than 24 hours each time. As for the lithium-ion batteries, please contact your battery supplier for the charging frequency and charging duration.

- **Fans**

Higher temperature will shorten fan life. When the UPS is running, please check if all fans work normally and make sure if air can move freely around and through the UPS. If not, please replace abnormal fans.

- 10" Color Touch Panel LCD

The LCD replacement procedures are as follows.

Step 1

① Open the UPS's two front doors, ② press the power button once to let it in the **OFF** status and ③ disconnect the LCD cable connected the LCD and the display port.

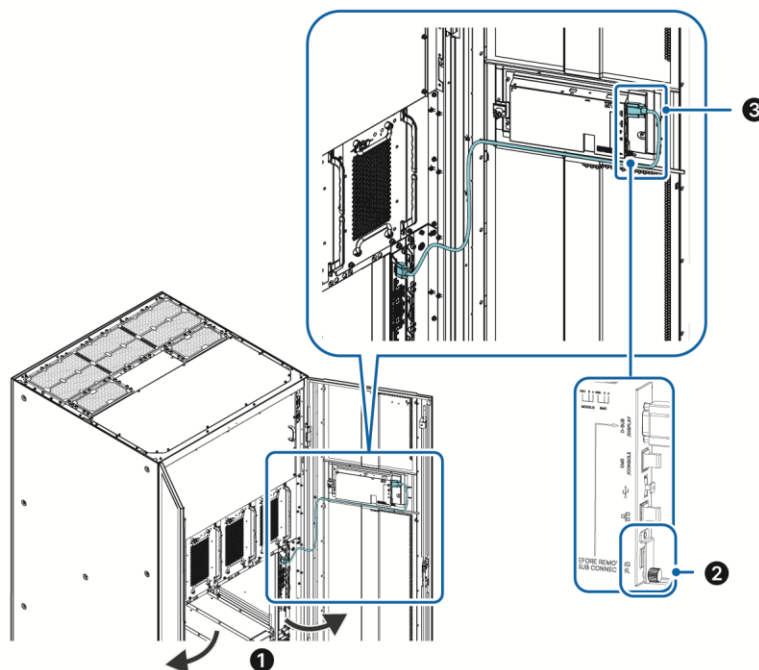

Figure 9-1: Open the Two Front Doors, Press the Power Button Off & Disconnect the LCD Cable

Step 2

Unscrew the six screws to remove the LCD, check if the new LCD's power button is in the **OFF** status and install the new LCD. After that, use the LCD cable to connect the new LCD and the display port and press the power button once to let it in the **ON** status.

Unscrew the Six Screws to Remove the LCD & Install a New One

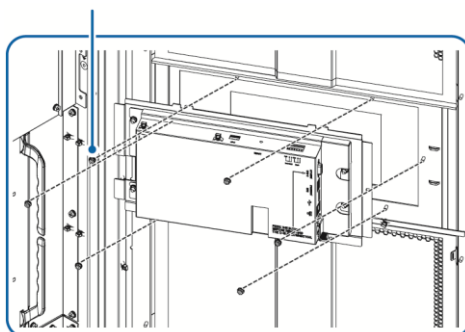

Figure 9-2: Unscrew the Six Screws to Remove the LCD & Install a New One

- **Dust Filters**

The dust filters' replacement procedures are as follows.

① Open the UPS's front doors. ② Unhook the retaining springs from the door hooks in order to remove eight retaining springs from the left door and ten from the right door. Next, ③ remove the three dust filters and install new ones on the Velcro attached to the doors. After that, ④ re-install the retaining springs.

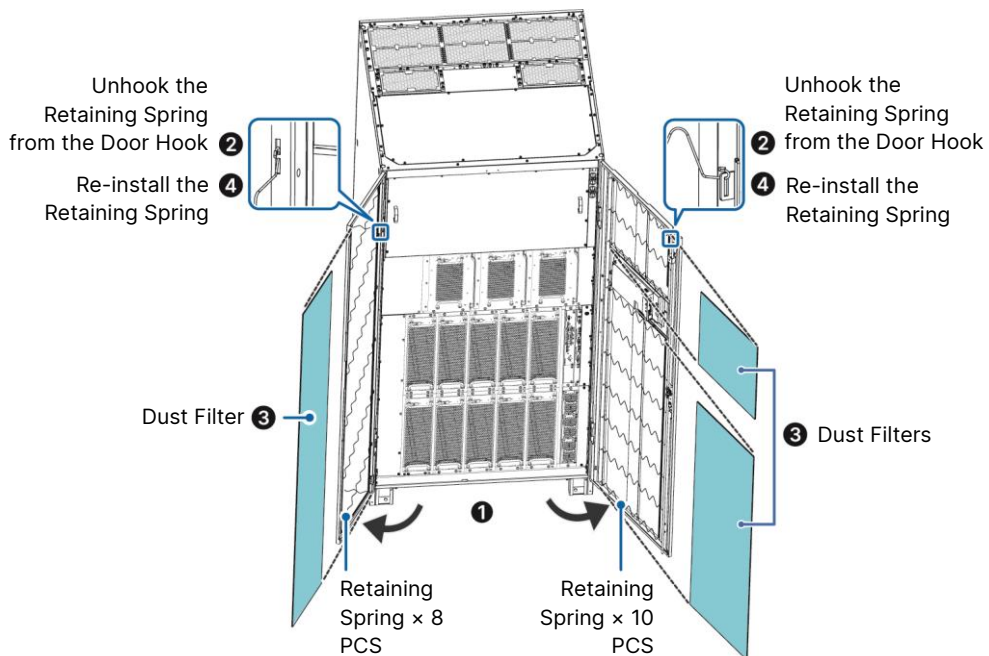

Figure 9-3: Remove the Retaining Springs and Dust Filters, Install the New Dust Filters and Re-install the Retaining Springs

Appendix 1 : Technical Specifications

Model		DPH G3-1250K				
Power Rating	kVA/kW	750kVA/ 750kW	875kVA/ 875kW	1000kVA/ 1000kW	1125kVA/ 1125kW	1250kVA/ 1250kW
	System Capacity	1250kVA/1250kW				
	Parallel Configuration	Up to 8 units				
Input	Nominal Voltage	220/380, 230/400, 240/415 Vac				
	Phase/Wire	3P4W + PE				
	Voltage Range	187 ~ 276 Vac (Ph-N, 100% load)*1 323 ~ 477 Vac (Ph-Ph, 100% load) 144 ~ 187 Vac (Ph-N, 70 ~100% load) 249 ~ 323 Vac (Ph-Ph, 70~100% load)				
	Frequency Range	40 ~ 70 Hz				
	Total Harmonic Distortion (THDi)	< 1.5% (linear load); < 3% (non-linear load)				
	Power Factor (100% load)	> 0.99				
	Short Circuit Withstand Rating	100 kA				
	Connection	Single or dual feed				
	Cable Entry	Top				
Bypass	Overload Capability	< 125%: continuous 1000%: 100 milliseconds				
	Bypass Fuse	14,500,000 A ² S				
Output	Nominal Voltage	220/380, 230/400, 240/415 Vac				
	Voltage Regulation	± 1% (static); ±3% (dynamic)				

Model		DPH G3-1250K				
Output (continued)	Frequency	50/60 Hz \pm 0.05 Hz				
	Total Harmonic Distortion (THDv)	< 1% (linear load); < 3% (non-linear load)				
	Power Factor	1				
	Permitted Load Power Factor	0.5 leading to 0.5 lagging without derating				
	Overload Capability	< 110 %: continuous*1; 110 ~ 125%: 10 minutes; 126 ~ 150%: 1 minute				
	Short-circuit Current (RMS)	2400A, 100 ms	2800A, 100 ms	3200A, 100 ms	3600A, 100 ms	4000A, 100 ms
	Phase Angle Accuracy w/ Balanced Loads	120 \pm 1°				
	Phase Angle Accuracy w/ Unbalanced Loads	120 \pm 1°				
	Range of Frequency Synchronized with Bypass	50/60 Hz \pm 5 Hz				
	Current Crest Ratio	3 : 1				
Efficiency	Online Mode	Up to 97.5%				
	ECO Mode	Up to 99%				
	Clean Mode	Up to 99%				
Battery	Battery Quantity	40 PCS (32 ~ 48 PCS adjustable (12V VRLA battery))				
	Battery Nominal Voltage	480 Vdc				

Model		DPH G3-1250K				
Battery (continued)	Battery Operational Voltage Limits	384 ~ 576 Vdc				
	Maximum Charge Current/ Per Module	40A				
Communication Interfaces	Display	10-inch color LCD touchscreen				
	Ports	SMART slot × 2, Modbus (RS-485) port × 1, REPO dry contact × 1, Input dry contact × 6, Output dry contact × 6, Synchronized Multiple Bus (SMB) port × 2, External breaker status dry contact × 4, EMS/Console (RJ45) port × 1, Ethernet × 1				
	REPO (Emergency Power Off)	Standard				
	Protocols	SNMP, Modbus, HTTP(S)				
Physical	Dimensions (W × D × H)	1000 × 1000 × 2060 mm (39.37" × 39.37" × 81.10")				
	Net Weight	1258 kg (2773.42 lb)	1318 kg (2905.69 lb)	1378 kg (3037.97 lb)	1438 kg (3170.25 lb)	1498 kg (3302.52 lb)
	Ventilation	Front to top (standard)				
	Service Access	Front and top				
Environment	Operating Temperature	0 ~ 40°C (32 ~ 104°F)				
	Humidity	0 ~ 95% (non-condensing)				
	Audible Noise	< 85 dBA*2				
	Altitude	0 ~ 1000 m (0 ~ 3280.84 ft) (derating 1% per 100 m (328.08 ft) from 1000 m (3280.84 ft) to 2000 m (6561.68 ft))				

Model		DPH G3-1250K
Environment (continued)	Storage Temperature	-20 ~ 70°C (-4 ~ 158°F)
	Storage Humidity	0 ~ 95% (non-condensing)
	Ingress Protection Level	IP20
Conformance	IEC Pollution Degree (PD)	PD 2
	Over Voltage Category (OVC)	OVC III
	Type of System Earthing	TN-S, TN-C, TN-C-S
	Safety	CE, RCM, UK
	EMC	IEC 62040-2
	Performance	IEC 62040-3
	Seismic Rating	GR63-zone 4
	Sustainability	RoHS, REACH

**NOTE:**

1. *¹ When the ambient temperature is < 30°C (86°F).
2. *² At a distance of 1 m (3.28 ft) in front of the UPS.
3. Please refer to the rating label for the safety certification.
4. All specifications are subject to change without prior notice.

Appendix 2 : Warranty

Seller warrants this product, if used in accordance with all applicable instructions, to be free from original defects in material and workmanship within the warranty period. If the product has any failure problem within the warranty period, Seller will repair or replace the product at its sole discretion according to the failure situation.

This warranty does not apply to normal wear or to damage resulting from improper installation, operation, usage, maintenance or irresistible force (i.e. war, fire, natural disaster, etc.), and this warranty also expressly excludes all incidental and consequential damages.

Maintenance service for a fee is provided for any damage out of the warranty period. If any maintenance is required, please directly contact the supplier or Seller.



WARNING:

The individual user should take care to determine prior to use whether the environment and the load characteristic are suitable, adequate or safe for the installation and the usage of this product. The User Manual must be carefully followed. Seller makes no representation or warranty as to the suitability or fitness of this product for any specific application.

No. : 501332830001

Version : 0.1

Release Date : 2026_02_05

Global Headquarter

Taiwan

Delta Electronics Inc.
30 Section 2, Huandong Road, Shanhua District,
Tainan City 74144, Taiwan
T +886 6 505 6565
E ups.taiwan@deltaww.com

Regional Office

Netherlands

Delta Electronics (Netherlands) B.V.
Zandsteen 15, 2132 MZ Hoofddorp, The Netherlands
T +31 (0)20 800 3900
E info@delta-emea.com

Poland

Delta Electronics (Poland) Sp. z o.o.
23 Poleczki St., 02-822 Warszawa, Poland
T +48 22 335 2600
E ups.poland@deltaww.com

Brazil

Delta Electronics Brasil Ltda.
Estrada Velha Rio-São Paulo, 5300 – Eugênio de Melo –
CEP 12247-001 São José dos Campos-SP-Brazil
T +55 12 39322300
E ups.brazil@deltaww.com

Peru

Delta Electronics (Peru) Inc. S.R.L.
Av. Pardo y Aliaga 699 Of. 601, San Isidro Lima, Peru.
T +51 962 834 287
E ups.peru@deltaww.com

China

Delta GreenTech (China) Co., Ltd.
238 Minxia Road, Pudong, Shanghai, 201209 P.R.C
T +86 21 5863 5678
+86 21 5863 9595
E ups.china@deltaww.com

South Korea

Delta Electronics (Korea), Inc.
1511, Byucksan Digital Valley 6-cha, Gasan-dong, Geumcheon-gu,
Seoul, Korea, 153-704
T +82-2-515-5303
E ups.south.korea@deltaww.com

Thailand

Delta Electronics (Thailand) Public Co.,Ltd.
909 Soi 9, Moo 4, E.P.Z., Bangpoo Industrial Estate, Tambon Phraksa,
Amphur Muang-samutprakarn, Samutprakarn Province 10280,
Thailand
T +662 709-2800
E ups.thailand@deltaww.com

Vietnam (Hanoi)

Delta Electronics (Vietnam) Co., Ltd.
3rd Floor, Vietnam 3D Creative Center Building, No. 3 Duy Tan Street,
Dich Vong Hau Ward, Cau Giay District, Hanoi City, Vietnam
T +84 966 532 266
E ups.vietnam@deltaww.com

Indonesia

Delta Electronics International (S) Pte Ltd.
Soho Capital, 30th Fl, Unit SC3009
Jl. Letjend S. Parman kav 28. Jakarta 11470 Indonesia
T + 65 9667 4687
E ups.indonesia@deltaww.com

UK

Delta Electronics (UK) Ltd.
Eltek House, Unit 1 Cleveland Road, Hemel Hempstead,
Hertfordshire, HP2 7EY, UK
T +44 1442 210805
E sales.gb@eltek.com

U.S.A

Delta Electronics (Americas) Ltd.
46101 Fremont Blvd. Fremont, CA 94538
T +1 510 668 5100
E ups.na@deltaww.com

Colombia

Delta Electronics Colombia SAS
Cra 72 # 95 – 51 Bodega 16, Parque Empresarial Los
Lagartos
Bogota DC, Colombia
T +57 317 4052794
E ups.colombia@deltaww.com

India

Delta Electronics India Pvt. Ltd.
Plot No. 43, Sector-35, HSIIDC, Gurgaon-122001,
Haryana, India
T +91 124 4874 900
E ups.india@deltaww.com

Japan

Delta Electronics (Japan), Inc.
2-1-14 Shibadaimon, Minato-Ku, Tokyo, 105-0012,
Japan
T +81-3-5733-1111
E jpstps@deltaww.com

Singapore

Delta Electronics Int'l (Singapore) Pte Ltd.
17 Kallang Junction, #01-01, TRION,
Singapore 339274
T +65 6747 5155
E ups.singapore@deltaww.com

Vietnam (Ho Chi Minh)

Delta Electronics (Vietnam) Co., Ltd.
10th Floor, The Galleria Office Building,
258 Nam Ky Khoi Nghia Street, Vo Thi Sau Ward,
District 3, Ho Chi Minh City, Vietnam
T +84 903 133 548
E ups.vietnam@deltaww.com

Philippines

Eltek Power Inc./ Delta
302 Orient Square Bldg
F. Ortigas JR Road, Barangay
San Antonio, Pasig City
1605 Philippines
E ups.philippines@deltaww.com

Australia

Delta Electronics (Australia) Pty Ltd.
St Leonard's Corporate Centre
Unit 18/39 Herbert Street, St Leonards NSW 2065, Australia
T +61 2 9479 4200
E ups.australia@deltaww.com



Smarter. Greener. Together.



5013328300