



The power behind competitiveness

# Delta InfraSuite Cooling

Rear Door Heat Exchanger (RDHx)  
CoolDoor 30/50 kW

User Manual

## SAVE THIS MANUAL

This manual contains important instructions and warnings that you should follow during the installation, operation, storage and maintenance of this product. Failure to heed these instructions and warnings will void the warranty.

Copyright © 2026 by Delta Electronics Inc. All Rights Reserved. All rights of this User Manual ("Manual"), including but not limited to the contents, information, and figures are solely owned and reserved by Delta Electronics Inc. ("Delta"). The Manual can only be applied to the operation or the use of this product. Any disposition, duplication, dissemination, reproduction, modification, translation, extraction, or usage of this Manual in whole or in part is prohibited without the prior written permission of Delta. Given that Delta will continuously improve and develop the product, changes may be made to the information in this Manual at any time without obligation to notify any person of such revision or changes. Delta will make all possible efforts to secure the accuracy and the integrity of this Manual. Delta disclaims any kinds or forms of warranty, guarantee, or undertaking, either expressly or implicitly, including but not limited to the completeness, faultlessness, accuracy, non-infringement, merchantability or fitness for a particular purpose of the Manual.

# Table of Contents

|  |           |
|--|-----------|
| <b>SAVE THIS MANUAL .....</b>                                      | <b>2</b>  |
| <b>Chapter 1 : Guide for Safe Operation.....</b>                   | <b>5</b>  |
| 1.1 Safety Instructions .....                                      | 5         |
| 1.1.1 Installation Instructions .....                              | 6         |
| 1.1.2 Instructions for Use.....                                    | 6         |
| 1.2 Nameplate Information .....                                    | 7         |
| 1.3 Product Introduction .....                                     | 8         |
| 1.4 Functions & Features .....                                     | 8         |
| 1.5 Dimensions .....   | 10        |
| 1.6 Design Capacity .....  | 12        |
| <b>Chapter 2 : Introduction.....</b>                               | <b>13</b> |
| 2.1 Packing List.....  | 13        |
| 2.2 Appearance.....  | 14        |
| 2.3 Component Identification .....                                 | 15        |
| 2.4 Piping System .....  | 17        |
| <b>Chapter 3 : Installation.....</b>                               | <b>18</b> |
| 3.1 Installation Site .....  | 18        |
| 3.2 Space Reservation .....  | 19        |
| 3.3 Handling .....   | 20        |
| 3.4 Positioning .....  | 21        |
| 3.4.1 Remove the Rack Door Panel.....                              | 21        |
| 3.4.2 Install CoolDoor Connect Duct .....                          | 22        |
| 3.4.3 Hang CoolDoor on Connect Duct .....                          | 23        |
| 3.5 Holing .....   | 23        |
| 3.6 Piping Installation Size.....                                  | 24        |
| 3.7 External Piping.....   | 25        |
| 3.8 CoolDoor Water Side Installation Components .....              | 26        |
| 3.8.1 CoolDoor Control Ball Valve (Standard Accessory).....        | 26        |
| 3.8.2 Pressure Independent Control Valve (Optional Accessory)..... | 27        |
| 3.8.3 Leakage Cut Off Valve (Optional Accessory).....              | 28        |

|  |           |
|--|-----------|
| 3.8.4 Flow Meter (Optional Accessory) .....                    | 29        |
| 3.9 Remote Sensor (Optional Accessory) .....                   | 30        |
| 3.10 Water Leakage Detection Sensor (Standard Accessory) ..... | 31        |
| 3.11 Water Quality Requirements .....                          | 32        |
| <b>Chapter 4 : Wiring .....</b>                                | <b>34</b> |
| 4.1 Connect the Power Cables .....                             | 34        |
| 4.2 Connect the Signal Cables .....                            | 35        |
| 4.3 Panel Diagram .....  | 38        |
| <b>Chapter 5 : Initial Start-up .....</b>                      | <b>43</b> |
| 5.1 Inspection Prior to Activation .....                       | 43        |
| 5.2 Operating Temperature & Humidity .....                     | 44        |
| 5.3 Power Supply .....   | 45        |
| 5.4 Ventilation .....  | 46        |
| 5.5 Water Volume Equilibrium .....                             | 47        |
| <b>Chapter 6 : Operation .....</b>                             | <b>48</b> |
| 6.1 Menu Tree .....  | 48        |
| 6.2 Control Panel .....  | 49        |
| 6.3 Status Page Operation .....                                | 50        |
| 6.4 Account Access Authorization & Log-in .....                | 59        |
| 6.5 Turbo Boost .....  | 59        |
| <b>Chapter 7 : Optional Accessories .....</b>                  | <b>62</b> |
| <b>Chapter 8 : Fault Code &amp; Description .....</b>          | <b>63</b> |
| 8.1 Troubleshooting .....                                      | 63        |
| 8.2 Warning Codes .....  | 65        |
| <b>Chapter 9 : Maintenance &amp; Cleaning .....</b>            | <b>72</b> |
| 9.1 Component Maintenance .....                                | 72        |
| 9.2 Component Replacement .....                                | 73        |
| 9.3 Quarterly Maintenance .....                                | 75        |
| <b>Chapter 10 : MODBUS Table .....</b>                         | <b>77</b> |
| <b>Appendix 1 : Technical Specifications .....</b>             | <b>79</b> |
| <b>Appendix 2 : Warranty .....</b>                             | <b>81</b> |

# Chapter 1 : Guide for Safe Operation

## 1.1 Safety Instructions

- Carefully read all chapters of the Manual before any installation, operation, or maintenance. To avoid personal injury and equipment damage, be sure to operate the product in accordance with the instructions in this Manual and the markings on the cabinet.
- The system has various hazards, including machinery, electrical appliances, sound, vibration and other hazards. Therefore, this must be performed by qualified professional operators, installation personnel and maintenance personnel who have received trained. This equipment has the following hazards:
  - Electric shock
  - High pressure water stream
  - Pinching in rotating components
  - Cuts from the heatsink
  - Crushing or falling-over from structural weight
- The unit should only be moved by at least two people so as to guarantee safety.
- In handling or removal of the equipment, pay attention to its height and center of gravity. When using transport equipment for handling, it must be raised from the bottom to avoid toppling.
- The unit contains moving components. Be careful to keep it away from arms, legs, hair, clothes and jewelry, so as to avoid any danger.
- When the CoolDoor, which has a certain weight, is installed in an empty rack, the counterweight in the rack should be appropriately increased to avoid tipping due to unstable center of gravity.

## 1.1.1 Installation Instructions

- Installation and operation should comply with local regulations. Installation professionals must have certification in accordance with national regulations. And the safety and health of personnel must be ensured at all times during the installation and removal processes.
- The unit can be connected to a single or dual power source. Make sure the input power is disconnected before making a connection. If necessary, use a multi-meter to confirm this.
- Do not install the equipment on a flammable or unstable floor.
- This unit is only intended for indoor use. The indoor environment must be separated from the outside air so as to avoid temperature and humidity interference. Consult national or local regulations for separating the installation environment.
- The diameters and length of all electronic connection wires must follow the requirements of the International IEC or relevant national regulations, whichever is stricter. Meanwhile, the grounding wires of the unit must be effectively connected with the grounding system.

## 1.1.2 Instructions for Use



- The inner high voltage of the unit may be fatal! The inner components may have hidden dangers and only qualified service personnel can operate the unit. Improper operation may lead to serious injury or death or equipment damage. Be sure to follow all the instructions and warnings contained in the Manual.
- When the person leaves, make sure there are no foreign objects in the cabinet.



### **WARNING:**

This device is powered by high voltage! May cause severe injury or death. Power supplied to the equipment must be isolated by an electrical cutoff device. Any and all electrical connections or procedures may only be performed by a certified electrician. All electrical work or procedures must comply with local, state, and national electrical standards and regulations. Except for the power supply, do not make any other electrical connections with this device.

## 1.2 Nameplate Information

|   |   |   |  |
|---|---|---|--|
|  |   | <br>XXXXXXXXXXXXXXX |  |
| Product   | : | Rear Door Cooling   |  |
| Model No.   | : | RWC050D0AK00B8  |  |
| Unit Name   | : | Cool Door 50kW  |  |
| Power Supply  | : | 1~ 200-240Vac Max 4.2A 50/60Hz  |  |
| MCA   | : | 4.5A  |  |
| MOP   | : | 5.5A  |  |
| Fan Motor , FLA/HP(Q'ty)  | : | 0.9A / 0.242HP(4)   |  |
| Rated Air Volume (Ref.)   | : | 4016 CFM (113.7 CMM)  |  |
| Max Allowable Inlet Pressure  | : | 142 psig (10 kg/cm <sup>2</sup> )   |  |
| Net Weight  | : | 216 lb (98 kg)  |  |
| Made in   | : | Taiwan  |  |

### Model Name

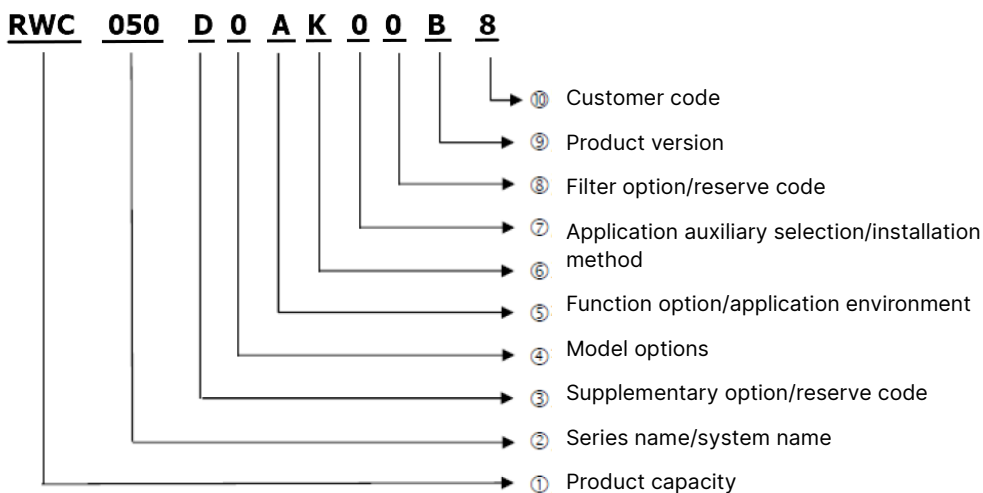

## 1.3 Product Introduction

The CoolDoor cooling device (chilled water type) is an air conditioning product that must be installed in combination with an IT rack or any standard rack, and is capable of quickly removing and outputting hot air from the racks. It can achieve precise control through the internal heat exchanger, EC fan, chilled water ball valve, and PLC control. On the outer frame, the side cover can be removed for parallel installation, so that the hot aisle can be shared to achieve the effect of mutual backup. For the installation of the chilled water pipeline, you can choose the cross-over joint or quick joint; the method of matching to the soft tubes is closer to the user's installation method. Because this product is used in direct combination with the rack, it goes beyond the traditional hot and cold aisle installation method, allowing the data center to be more compact with a high-density heat dissipation method.

## 1.4 Functions & Features

- **Intelligent control**

The built-in MCU accurately detects and balances the data center's heating load change, automatically adjusting the CoolDoor's chilled water flow and air flow to meet the temperature control target.

- **User-friendly control interface**

Easy setting and monitoring and access to system status.

- **Two-way ball valve**

Provides proper flow of chilled water to dissipate heat. When the power supply is in an emergency shutdown state, the valve spring is reset to the closed state to avoid continuous supply of ice water when it is ineffective.

- **Electronically commutated fan**

The unit is equipped with high efficiency EC fans; the fan speed is adjustable from 30 to 100% for more energy saving.

- **Alarm system**

The fire smoke sensor can use the input dry contact to execute an alarm; it can be emergency shut down according to customer needs. And it can alert users through MODBUS RTU.

- **Hot aisle expansion**

Disassembly and installation can be performed through the side panels of the CoolDoor to achieve sharing of the hot aisle and partial backup for adjacent CoolDoor-Rack systems.

- **Lockable access door**

The CoolDoor includes a locking mechanism to prevent unrelated personnel from opening it. The access door is located in the front, which facilitates professionals performing maintenance.

- **Built-in ATS**

When there is a main Feed A fault, this will transfer to Feed B, to keep the unit working normally.

- **Water Leakage detection**

A 4m water leakage detector can immediately inform the user of any water leakage to protect the safety of the equipment. The optional cut off valve to cut off the water inlet and outlet can avoid the expansion of water leakage.

- **Remote control**

Remote control via the input dry contact.

- **Turbo boost control**

It is a fail-safe design. When the machine fails to work normally, the adjacent CoolDoor will monitor and assist in the operation to reduce the heat load.

## 1.5 Dimensions

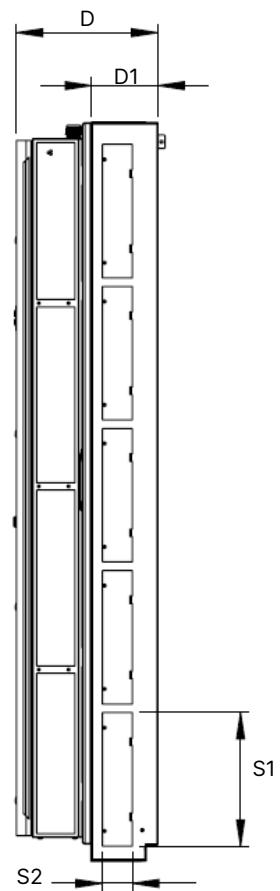
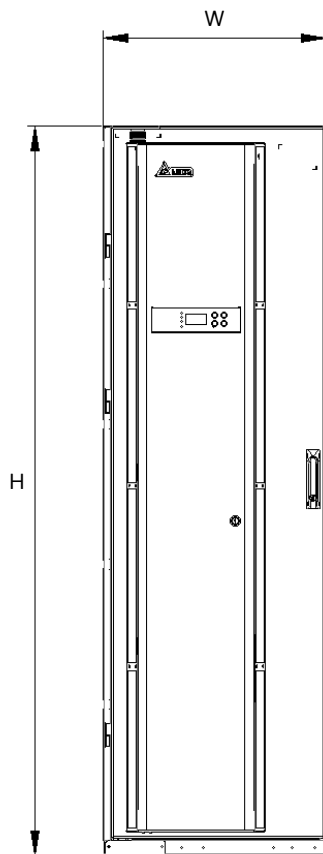
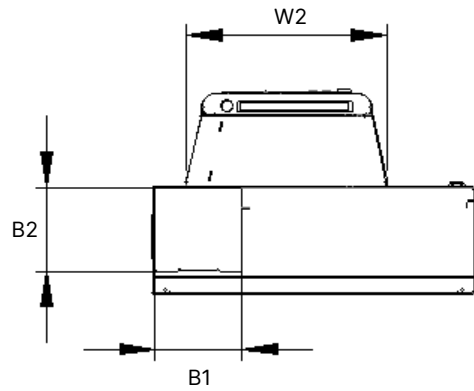
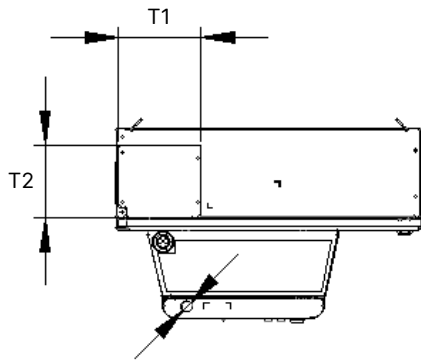

| Model No.      | H       | W        | W2     | D        | D1     | S1     |
|----------------|---------|----------|--------|----------|--------|--------|
| RWC050D0AK00B8 | 1968 mm | 600.4 mm | 373 mm | 375.6 mm | 176 mm | 355 mm |
|                | T1      | T2       | T3     | B1       | B2     | S2     |
|                | 160 mm  | 143 mm   | 22 mm  | 160 mm   | 135 mm | 80 mm  |

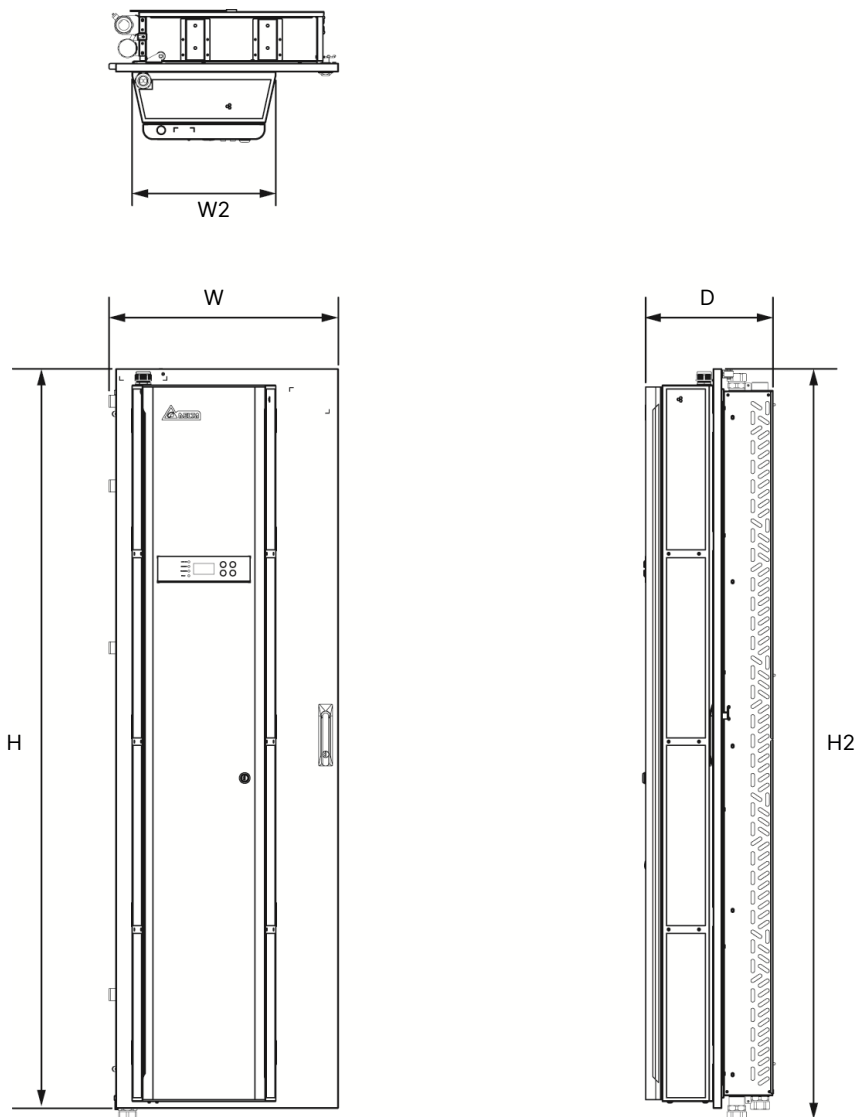

| Model No.       | H          | H2         | W           | W2        | D           |
|-----------------|------------|------------|-------------|-----------|-------------|
| CLSRD503ATT01-0 | 1919<br>mm | 1948<br>mm | 595.5<br>mm | 373<br>mm | 330.8<br>mm |
| CLSRD503ATT02-0 |            |            |             |           |             |

## 1.6 Design Capacity

| CoolDoor                          | Unit | Quantity                |
|-----------------------------------|------|-------------------------|
| <b>Duct connection</b>            |      |                         |
| Rack Unit Height                  | U    | 42U-48U                 |
| Rack Unit Width                   | mm   | 600-800mm               |
| Rack Unit Deep                    | Inch | 12                      |
| <b>Water Side</b>                 |      |                         |
| Fluid Type                        |      | Water or Glycol         |
| Fluid Flow                        | GPM  | <23.8                   |
| Pressure Drop (coil + ball valve) | Psi  | 9.4                     |
| Inlet Temperature                 | °F   | 53.6~68                 |
| Cooling Capacity                  | kW   | <53                     |
| Max Allowable Inlet Pressure      | Psig | 142                     |
| <b>Air Side</b>                   |      |                         |
| Air Volume                        | CFM  | 2000~4016               |
| <b>Cabinet</b>                    |      |                         |
| Approximate Shipping Weight       | Lbs  | 367-385                 |
| Approximate Operating Weight      | Lbs  | 198-216                 |
| <b>Electricity</b>                |      |                         |
| Power Supply                      |      | 200-240V / 1N / 50,60Hz |
| MCA                               | A    | 4.5                     |
| MOP                               | A    | 5.5                     |

The range of design conditions shown in the above table will vary with the user's design ability, water volume, and different return air temperature. It is recommended that you contact Delta service personnel and provide them with detailed calculation parameters in the design.

# Chapter 2 : Introduction

## 2.1 Packing List



| No. | Description                        | Quantity | Standard Part |
|-----|------------------------------------|----------|---------------|
| ①   | CoolDoor Cooling Unit              | 1        | V             |
| ②   | User Manual                        | 1        | V             |
| ③   | Door Key                           | 2        | V             |
| ④   | Ball Valve Body                    | 1        | V             |
| ⑤   | Ball Valve Actuator                | 1        | V             |
| ⑥   | Pressure Independent Control Valve | 1        |               |
| ⑦   | Electric Shut-off Valve            | 1        |               |
| ⑧   | Remote Sensor                      | 1        |               |

## 2.2 Appearance

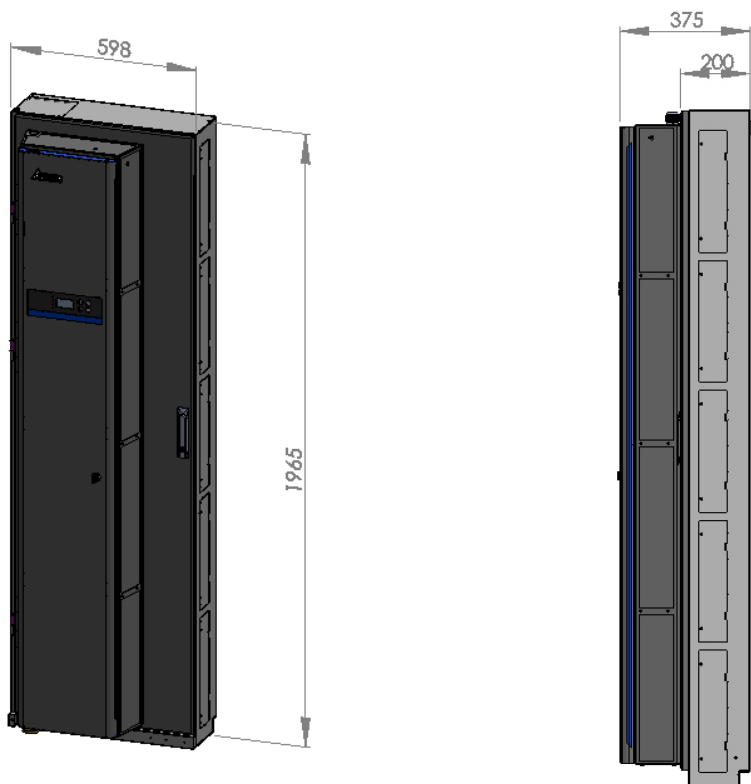

Figure 2-1: Outer Dimensions

## 2.3 Component Identification

### External

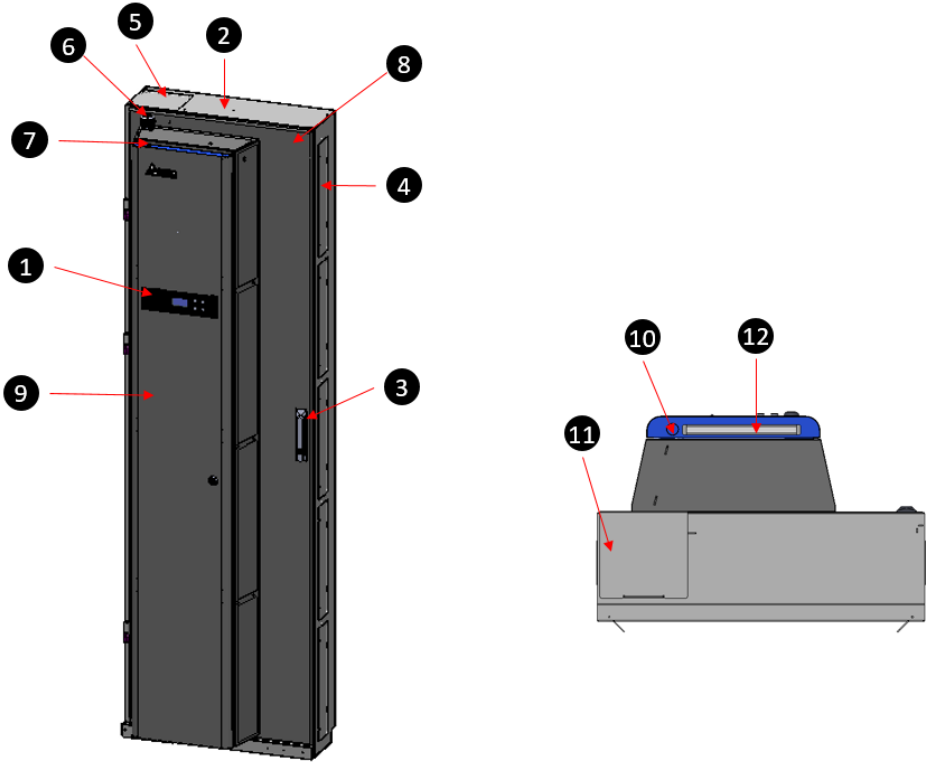

Figure 2-2: External View

| No. | Description            | No. | Description               |
|-----|------------------------|-----|---------------------------|
| 1   | Display Panel          | 7   | Upper Signal Cable Inlet  |
| 2   | Connect Duct           | 8   | Rear Door                 |
| 3   | Handle                 | 9   | Control Panel Cover       |
| 4   | Hot Aisle Cover        | 10  | Bottom Signal Cable Inlet |
| 5   | Upper Water Pipe Inlet | 11  | Bottom Water Pipe Inlet   |
| 6   | Power Cable Inlet      | 12  | Status LED                |

Internal

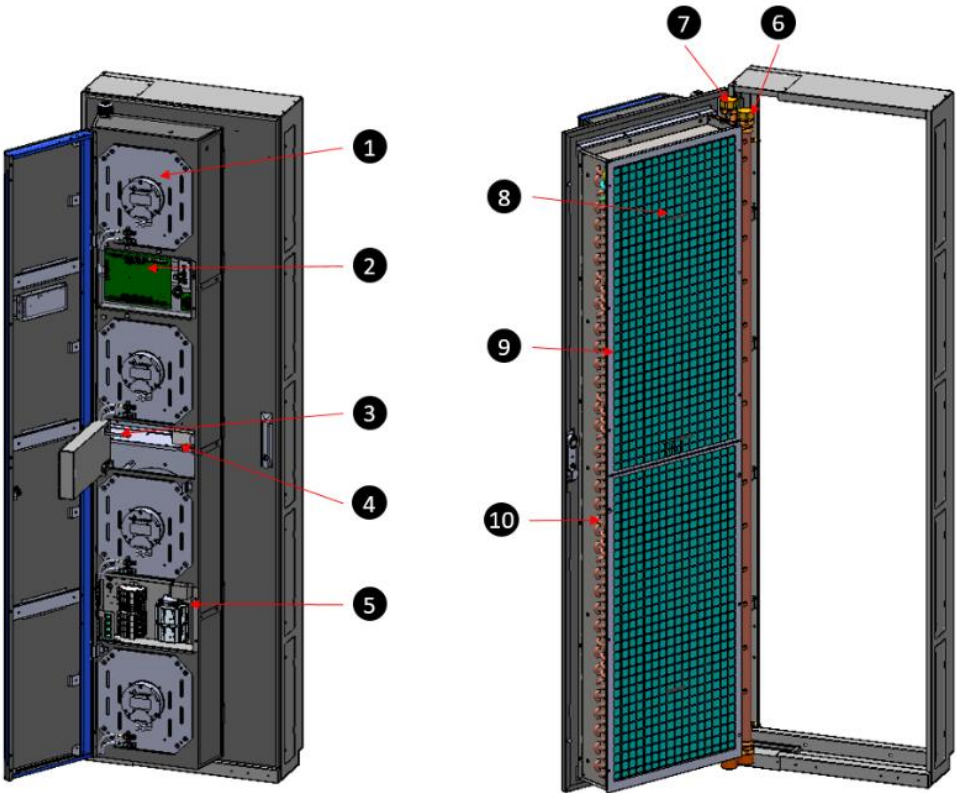

Figure 2-3: Internal View

| No. | Description                   | No. | Description                   |
|-----|-------------------------------|-----|-------------------------------|
| 1   | Fan                           | 6   | Outlet Pipe                   |
| 2   | Control Panel                 | 7   | Inlet Pipe                    |
| 3   | Supply Air Temperature Sensor | 8   | Return Air Temperature Sensor |
| 4   | Air Pressure Detector         | 9   | Coil Protector                |
| 5   | Electronic Panel              | 10  | Coil                          |

## 2.4 Piping System

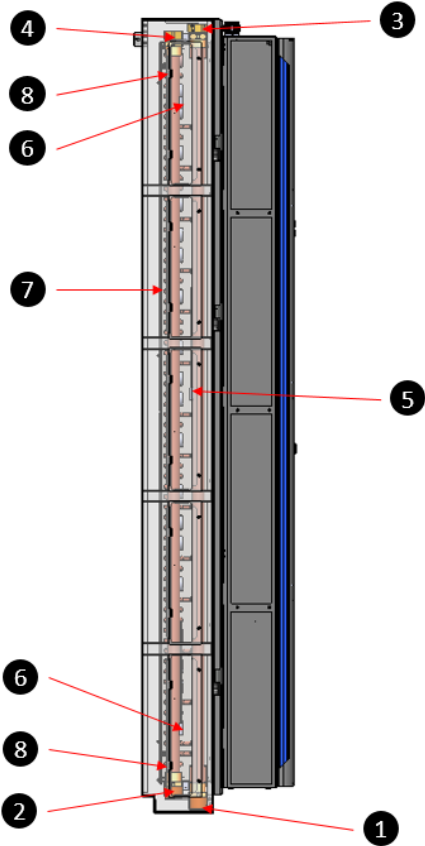

Figure 2-4: Piping System

| No. | Description            | No. | Description                     |
|-----|------------------------|-----|---------------------------------|
| 1   | Lower inlet connector  | 5   | Inlet water temperature sensor  |
| 2   | Lower outlet connector | 6   | Outlet water temperature sensor |
| 3   | Upper inlet connector  | 7   | Coil                            |
| 4   | Upper outlet connector | 8   | Air Vent                        |

## Chapter 3 : Installation



### WARNING:

1. Only service personnel can perform the following installation procedures. No installation, piping or handling should be performed without authorization, so as to avoid equipment damage and personal injury.
2. The high voltage in the equipment is potentially fatal! The inner components have potential dangers and only qualified service personnel can perform wiring.

### 3.1 Installation Site

When planning the installation site for the cooling unit, you must take the following into consideration so as to guarantee the best efficiency.

- **Environmental requirements:** The installation site must allow for moving the equipment into and out of the site; the flooring must bear the weight of the equipment; and there must be a sufficient space for maintenance, operation, and pipe repair. The cooling unit can only be located indoors, and the indoor environment must be isolated from the outside air to avoid temperature and humidity interference. The outside humidity entry must be minimized in accordance with the local or national regulations so as to avoid the increase of operation costs due to loss of cooling capacity.
- **Humidity and heat source:** Implement water-proofing and heat insulation engineering for the indoor environment to isolate the outside humid hot air.



### NOTE:

The unit cannot humidify or automatically de-humidify. If the humidity of the installation environment exceeds the operation scope (refer to **5.2 Operating Temperature & Humidity**), the condensation of the water on the coil and pipes may lead to trigger an alarm.

- **Noise impact:** At a high load, the operation of this cooling unit may produce loud noise. Therefore, it is not suitable to install the unit close to offices.
- **Input power:** In connecting the power supply, make sure that the power conforms to the rated value, and that the power distribution device is sufficient to satisfy the load requirement. Inspect the rated values of each unit and make sure they have been properly grounded. One branch circuit or power distribution device can only be connected with one cooling unit.

## 3.2 Space Reservation

To facilitate maintenance and operation and to promote air flow circulation, leave clearance in the equipment's surroundings.

1. To ensure normal operation of the indoor unit, whenever possible, select a spacious room to install the indoor unit in. It is advised to leave at least 2.5 feet on the rear where the door opens to facilitate wiring and piping, as is shown in **Figure 3-1**.

If lower piping is adopted, the height of the elevation stand may not be less than 2 feet.

2. Avoid placing the indoor unit in a narrow place; otherwise, it will obstruct air flow and shorten the cooling cycle, resulting in air return short circuit and air noise.
3. Avoid placing the indoor unit in a dead end or at the end of a narrow and long space.
4. To facilitate daily care and maintenance, do not install other equipment in the airway above the air handling unit.

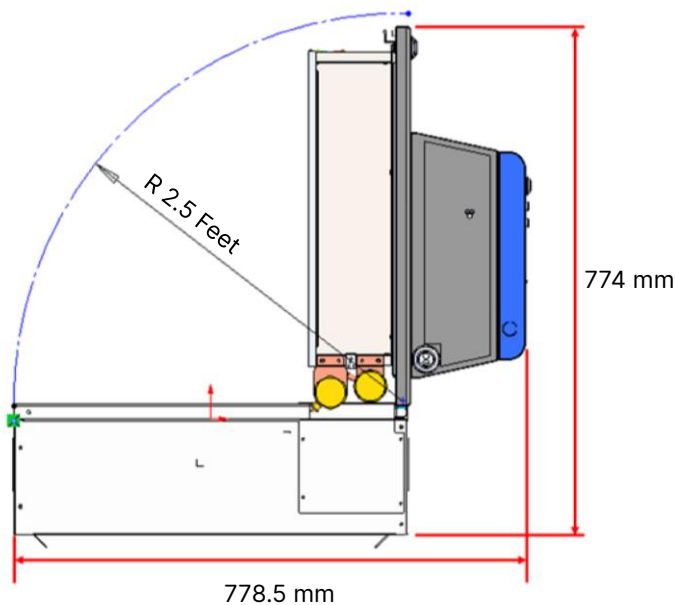

Figure 3-1: Clearance Area

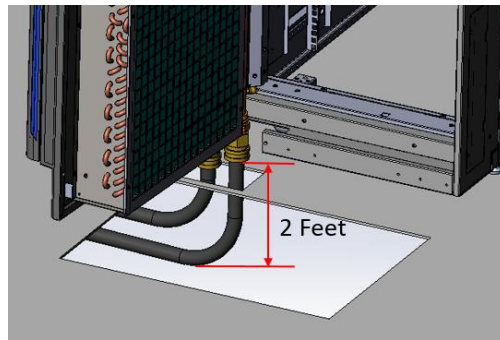

Figure 3-2: Under Floor Piping

### 3.3 Handling

#### Transport

Before relocating this equipment to the installation site, follow the precautions below and plan the transport route:

1. Make sure that the passageway, floor, elevator, or ramp along the transport route can withstand the weight of this equipment and the transport equipment, and clear the passageway in order to avoid collision.
2. In case of a slope along the transport route, the incline may not be greater than 15 degrees, in order to avoid toppling of the cabinet.
3. When relocating the cabinet over a long distance, use transportation equipment such as the forklift in *Figure 3-3* or the hoist in *Figure 3-4*.
4. When relocating this equipment, mind the height of the center of gravity. Transport requires at least two people at the same time, in order to ensure safety.



Figure 3-3: Transport with A Forklift

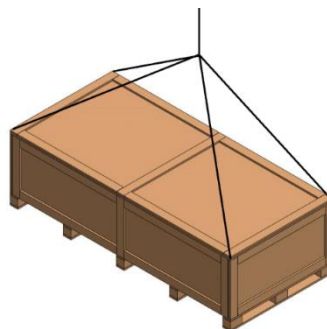

Figure 3-4: Transport with A Hoist

## 3.4 Positioning

After this equipment is relocated to a fixed site, positioning is required in order to ensure that the cabinet is stable and secure. Depending on installation setting, the following approaches may be adopted:

### 3.4.1 Remove the Rack Door Panel

- If Delta's dedicated rack model MSR1110 is used, you must remove the rear door before installing the CoolDoor extension frame. Follow the steps below:
  1. If the back door is locked, use the attached key to open it.
  2. Remove the ground wire, and lift up to remove the two back doors.
  3. Remove the 4 door hinge fixing plates and 2 coupling pieces.

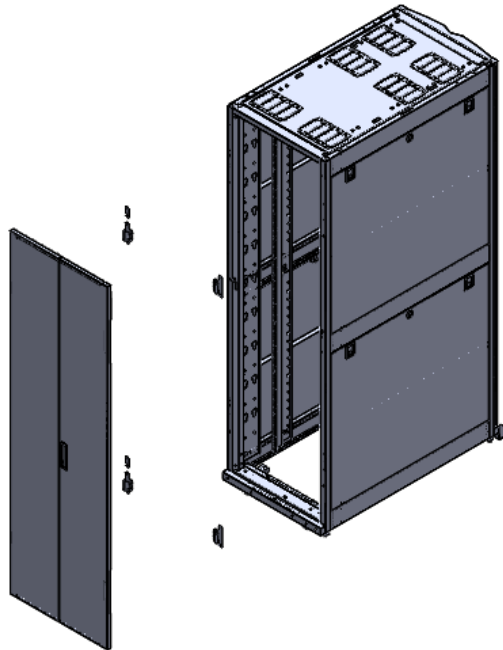

Figure 3-5: Remove Rear Door

### 3.4.2 Install CoolDoor Connect Duct

- Use M4 screws (8 PCS) and M6 screws (4 PCS) packed in the accessory bag to fix the extension frame to the rack

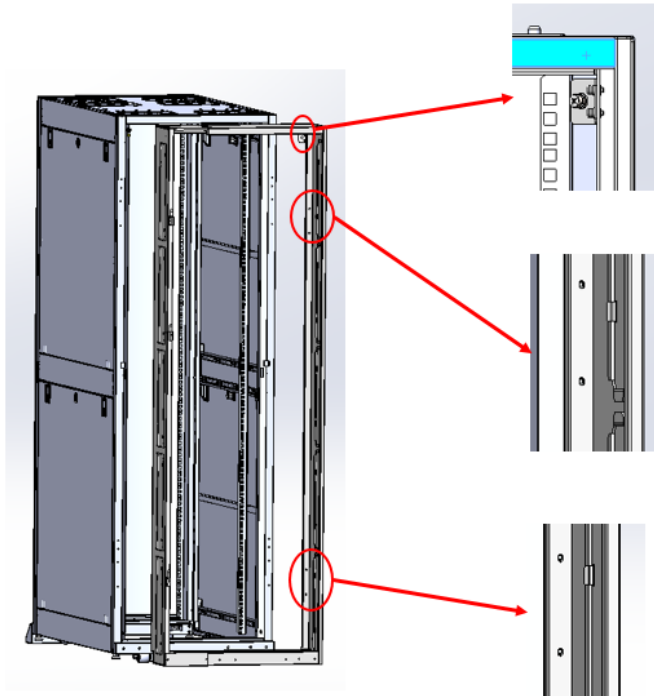
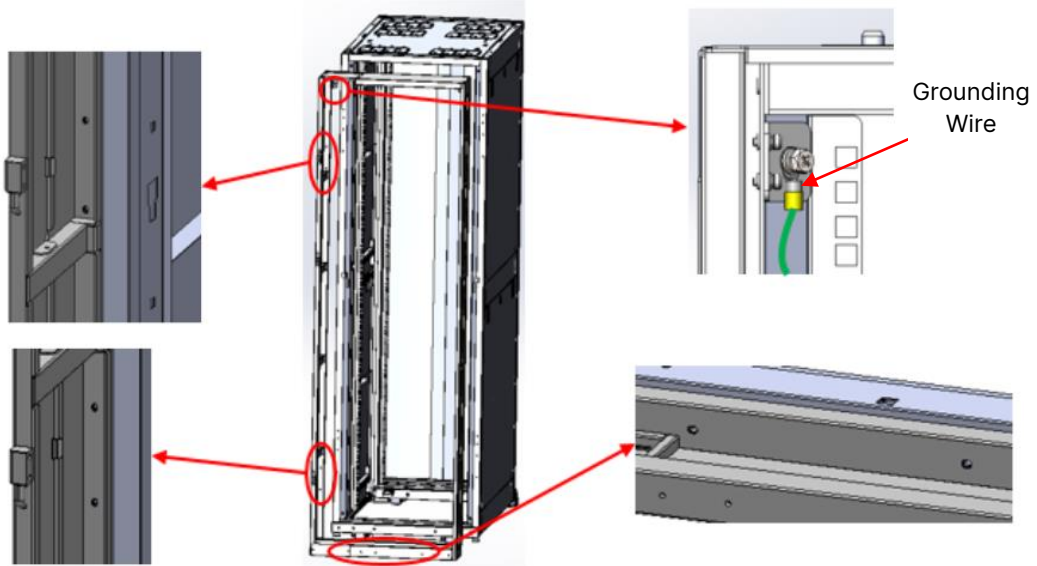

Figure 3-6: Fix Position

### 3.4.3 Hang CoolDoor on Connect Duct

- Use a lifting harness to stand up the CoolDoor, then align the three hinges to hang it above Connect Duct

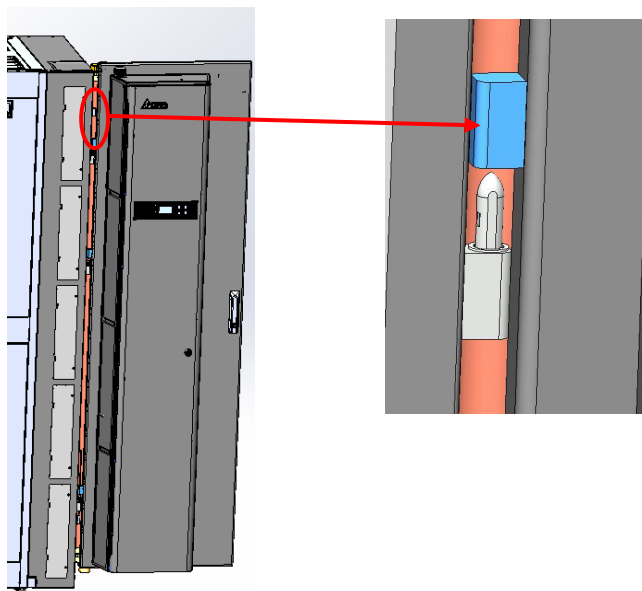
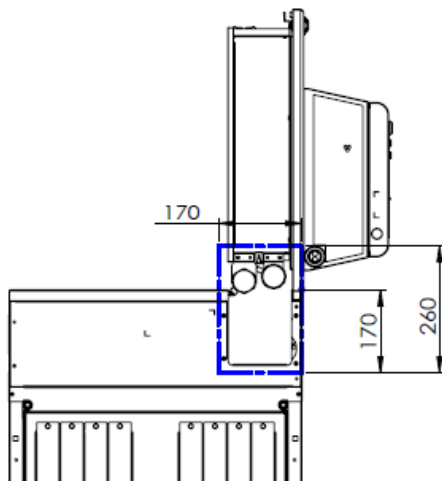

Figure 3-7: Insert to Hinge

### 3.5 Holing

Make holes according to the diagram and piping method (upper, lower piping) in the raised floor or ceiling to allow the pipes to pass through.



The outer layer of the pipe is covered with an insulation layer to reduce damage from external collisions or unintentional condensation that can lead to dripping. Leave a margin of about 13mm for the hole diameter. The figure below shows the position of the power cable and signal cable at the door.

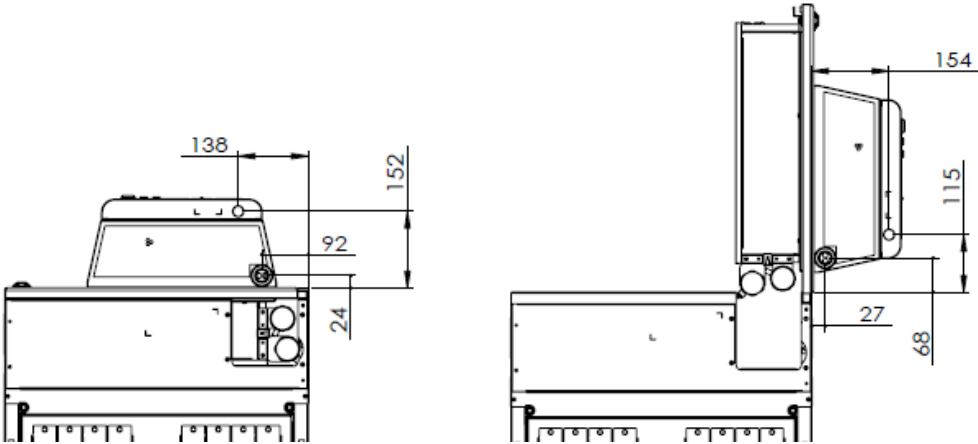

### 3.6 Piping Installation Size

| No. | Description | D30         | D50             |
|-----|-------------|-------------|-----------------|
| 1   | Inlet Pipe  | 1B-NPT-male | 1 1/4B-NPT-male |
| 2   | Outlet Pipe | 1B-NPT-male | 1 1/4B-NPT-male |

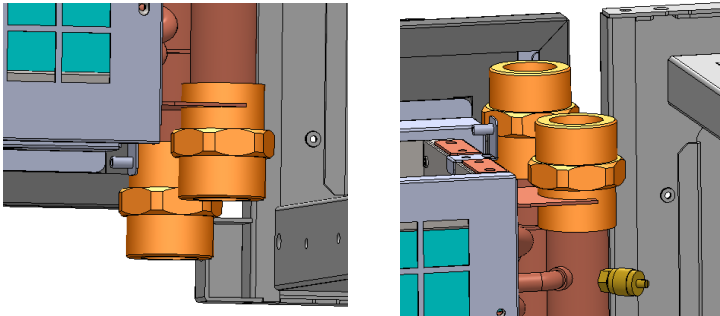
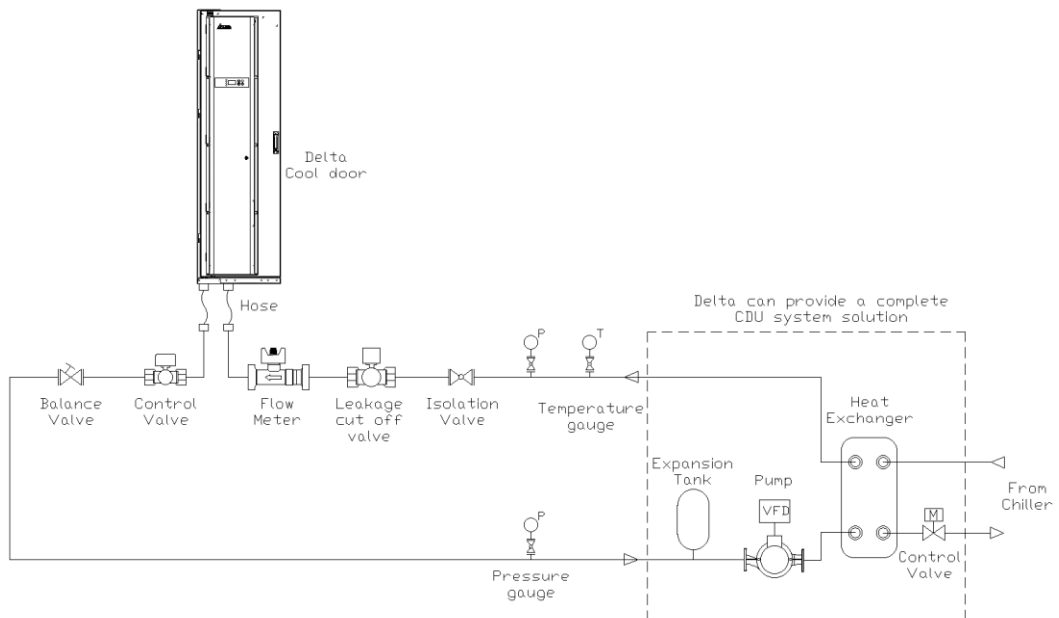

Figure 3-8: Pipe thread

### 3.7 External Piping



**Figure 3-9: External Piping**

As shown in *Figure 3-9*, the door of the CoolDoor will open and close during application. Therefore, pipes must be fitted at the water inlet and outlet. Note that the soft tubes and connections must be able to have acceptable rotation. The standard of connection is a screw cross-over joint, or an optional quick joint. Install the ball valve provided by Delta on the outlet pipe behind the soft tube. After the external pipeline is established, it is recommended that you hold the pressure to check whether the connections are leaking or not. The holding pressure should not be higher than the maximum pressure of the CoolDoor, 142 psig. Delta recommends installing isolation valves on the water outlet before the ball valve of the CoolDoor and on the water inlet before the soft tube, which will allow for maintenance and disassembly.

Delta recommends using a closed water system for chilled water supply. The system has independent pumps, expansion tanks, and heat exchangers to prevent outside pollution from entering the system and ensure the operating efficiency of the CoolDoor.

- Pipeline washing

To guarantee cooling efficiency, you must purify the pipeline to filter out impurities and chemical substances. For pipeline washing, use a hose to create a short circuit that makes the chilled water go directly from the inlet end to the return end, without passing through the cooling unit. If your pipeline system has a Y-filter, please install a fine-meshed filter (20-mesh suggested) in it to filter out the fine impurities; after 12h-24h of water circulation in the pipeline, change to a larger-meshed filter (3-mesh suggested).

## 3.8 CoolDoor Water Side Installation Components

### 3.8.1 CoolDoor Control Ball Valve (Standard Accessory)

#### 2-Way Ball Valve Installation

- Delta provides a chilled water control 2-way NPT ball valve that has a spring return function.
- The valve is usually installed in the chilled water supply channel on site. At the end of the soft tube of the water outlet of the CoolDoor, the customer supply channel is installed under the raised floor.
- Power wiring is performed according to the terminal wire colors, as shown in *Figure 3-10*. The ball valve has directionality; direction of water flow is from A to AB. A is connected to the outlet of the soft tube, and AB is connected to the external piping.

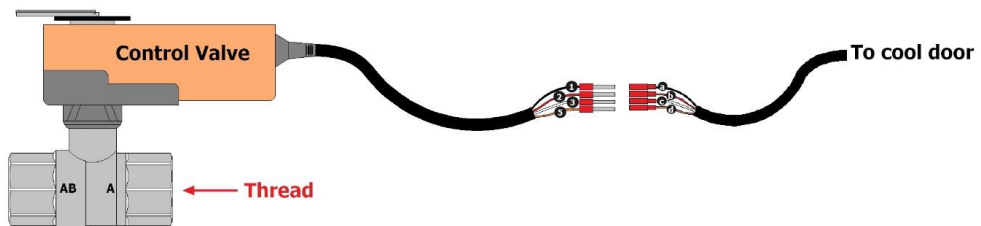

Figure 3-10: Ball Valve

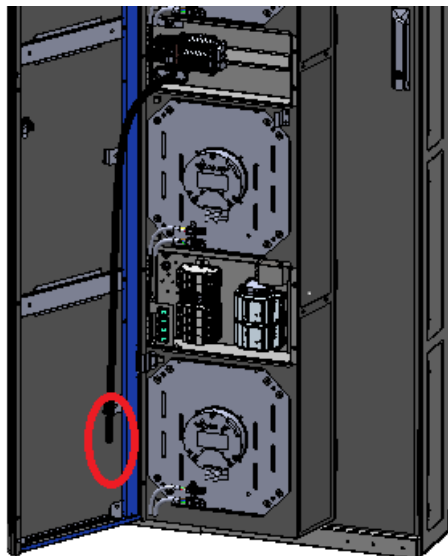

Figure 3-11: Location of the Ball Valve Connector

| Ball Valve               | Link                        |
|--------------------------|-----------------------------|
| Flow direction (A to AB) | Refer to <i>Figure 3-10</i> |
| Internal thread          | NPT                         |
| 1. GND-Black             | Wire to a (GND-Black)       |
| 2. DC24V-Red             | Wire to b (VCC-Red)         |
| 3. Comment-White         | Wire to c (DRV-White)       |
| 5. Feedback-Orange       | Wire to d (STD-Brown)       |

- The valve should be installed in accordance with standard piping and local HVAC codes. If necessary, it is recommended that you install a filter at the inlet of the CoolDoor.
- For the location of the ball valve connector, please refer to *Figure 3-11*.

### 3.8.2 Pressure Independent Control Valve (Optional Accessory)

- In order to solve customer's water balance issues when multiple CoolDoors in parallel are applied, Delta provides an optional Pressure Independent Control Valve (NPT & 2-way) that has flow monitoring function to avoid installation of an extra balance valve.
- The valve is usually installed in the chilled water supply channel on site. At the end of the soft tube of the water outlet of the CoolDoor, the customer supply channel is installed under the raised floor.
- Power wiring is performed according to the terminal wire colors, as shown in *Figure 3-12*. The ball valve has directionality; direction of water flow is from A to AB. A is connected to the outlet of the soft tube, and AB is connected to the external piping.

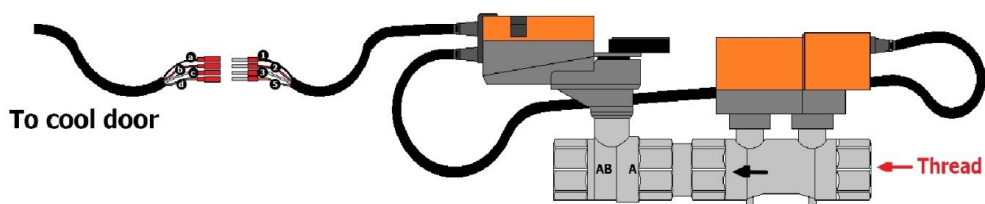

Figure 3-12: Pressure Independent Control Valve

| PICV                     | Link                        |
|--------------------------|-----------------------------|
| Flow direction (A to AB) | Refer to <i>Figure 3-12</i> |
| Internal thread          | NPT                         |
| 1. GND-Black             | Wire to a (GND-Black)       |
| 2. DC24V-Red             | Wire to b (VCC-Red)         |
| 3. Comment-White         | Wire to c (DRV-White)       |
| 5. Feedback-Orange       | Wire to d (STD-Brown)       |

- The valve should be installed in accordance with standard piping and local HVAC codes. If necessary, it is recommended that you install a filter at the inlet of the CoolDoor.
- For the location of the ball valve connector, please refer to *Figure 3-11*.

### 3.8.3 Leakage Cut Off Valve (Optional Accessory)

- The Leakage Cut Off Valve can be closed at the same time as the ball valve when the pipeline is leaking to avoid risk of leakage from contacting surrounding electrical appliances.
- The valve is usually installed in the chilled water supply pipeline on site, at the inlet of the soft tube at the water inlet of the CoolDoor, and the customer supply pipeline is installed under the raised floor.
- Power wiring is performed according to the terminal wire colors, as shown in *Figure 3-13*. The ball valve has directionality; direction of water flow is from A to AB. A is connected to the outer piping, and AB is connected to the soft tube inlet.

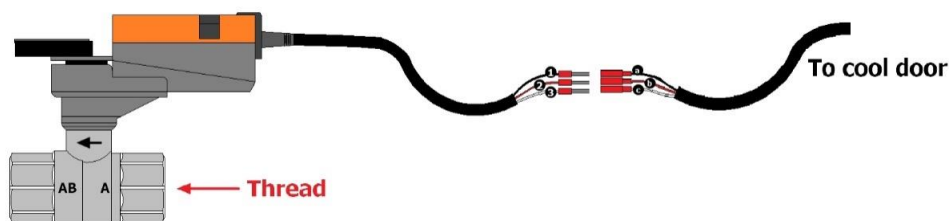

Figure 3-13: Cut Off Valve

| Leakage Shut Off Valve   | Link                        |
|--------------------------|-----------------------------|
| Flow direction (A to AB) | Refer to <b>Figure 3-13</b> |
| Internal thread          | NPT                         |
| 1.GND-Black              | Wire to a (GND-Black)       |
| 2.DC24V-Red              | Wire to b (VCC-Red)         |
| 3.Comment-White          | Wire to c (DRV-White)       |

- The valve should be installed in accordance with standard piping and local HVAC codes. If necessary, it is recommended that you install a filter at the inlet of the CoolDoor.
- For the location of the ball valve connector, please refer to **Figure 3-11**.

### 3.8.4 Flow Meter (Optional Accessory)

- It is recommended that you install a flow meter on the CoolDoor’s supply pipeline to ensure sufficient flow of all CoolDoors and adjust for accurate balance values. Delta provides flow meter options for customers.
- The flow meter is usually installed in the chilled water supply pipeline on site, at the inlet of the soft tube at the water inlet of the CoolDoor, and the customer supply pipeline is installed under the raised floor. When installing the flow meter, maintain a distance of 5 times the pipe diameter from the front pipe.
- Connect the power supply to the corresponding position of the terminal block, as shown in **Figure 3-14**. This flow meter is directional, and the direction of water flow is the same as that of the arrow. The inlet is connected to the outer piping, and the outlet is connected to the inlet soft tube.

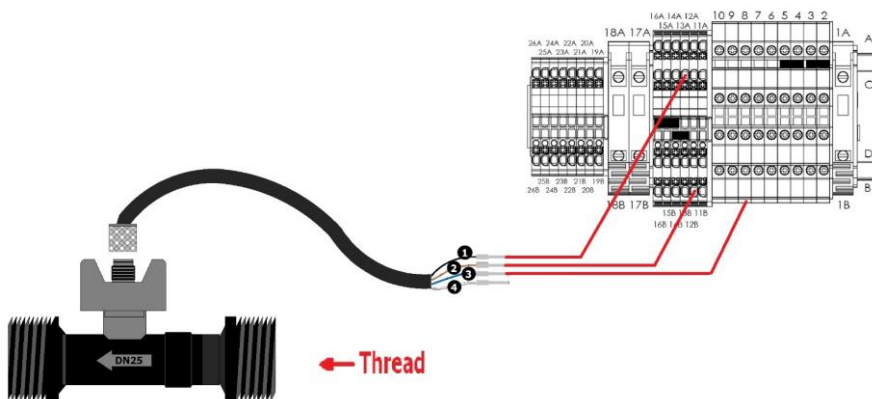

Figure 3-14: Flow Meter

| Flow Meter       | Link                        |
|------------------|-----------------------------|
| Flow direction   | Refer to <i>Figure 3-14</i> |
| External thread  | G1-1/4" (BSP)               |
| 1. GND-Black     | Wire to 13A                 |
| 2. DC24V-Brown   | Wire to 12B                 |
| 3. Feedback-Blue | Wire to 8B                  |
| 4. NA-White      | Wire cut off                |

Test all on-site pipes and connections for air or nitrogen leakage (50psi at maximum), and then fill and exhaust the system. Only when the system pressure test shows no leakage can you continue filling and exhausting the system.

### 3.9 Remote Sensor (Optional Accessory)

- It is recommended that you install a remote sensor at the entrance of the server rack to monitor the environmental dew point temperature so that the CoolDoor will give an alarm when the risk of condensation is high. It is recommended that you install a remote sensor every 5 to 7 racks. Delta provides remote sensor options for customers.
- The sensor wiring terminal is RJ-11, which is connected to the sensor through the connection point of the control board (as shown in *Figure 3-15*), and the connection line can be pulled out by the door knocker on the top. When the remote sensor is fixed in the cold aisle at the entrance of the server rack, it is recommended that you use M4 screws to fix it.
- If you want to share a remote sensor for multiple units, you can turn on the Turbo boost function. Up to 7 CoolDoors can share a remote sensor.

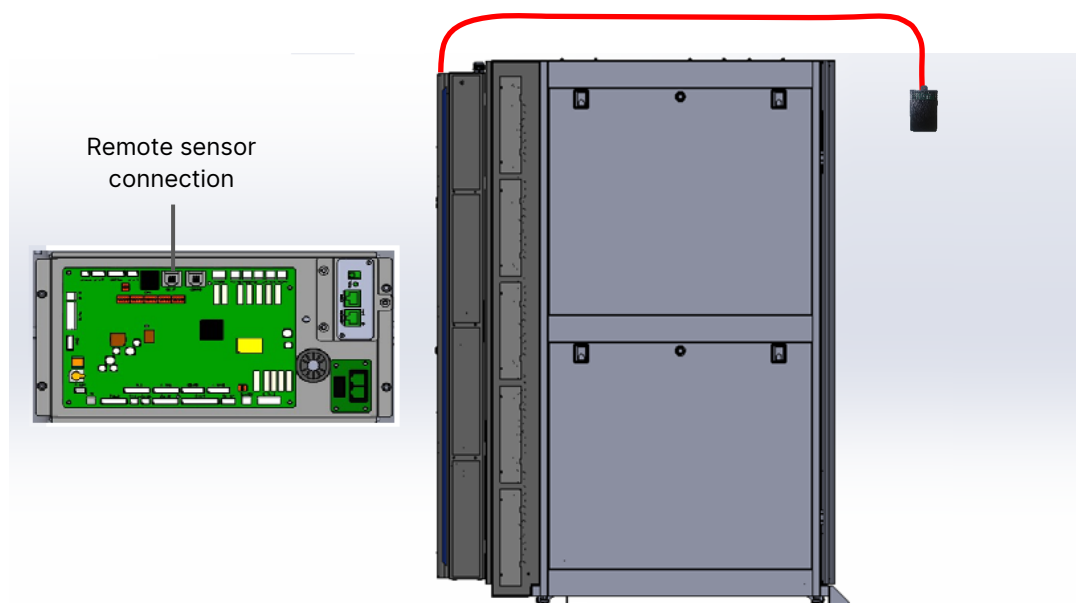

Figure 3-15: Remote Sensor Configuration

### 3.10 Water Leakage Detection Sensor (Standard Accessory)

There is a leakage detection sensor in the CoolDoor accessory kit. Connect the leakage detection sensor to the connector (see *Figure 3-16*) located near the control panel, and route it through the signal line port to let the sensor come out from the bottom of the rack as shown in *Figure 3-17*.



Figure 3-16: Leakage Detection Sensor &amp; Connector

The recommended layout of the leakage detection sensor is shown in *Figure 3-17*.

### **Method 1:**

Route it around the CoolDoor and rack.

### **Method 2:**

Place it under the elevated floor.

It can be fixed with suitable non-conductive glue (silicone glue).



#### **NOTE:**

The humidity in the lower pipeline might be too high. It is recommended that you use an insulation cotton to cover the pipeline to avoid false triggering of the leakage detection sensor due to condensate.

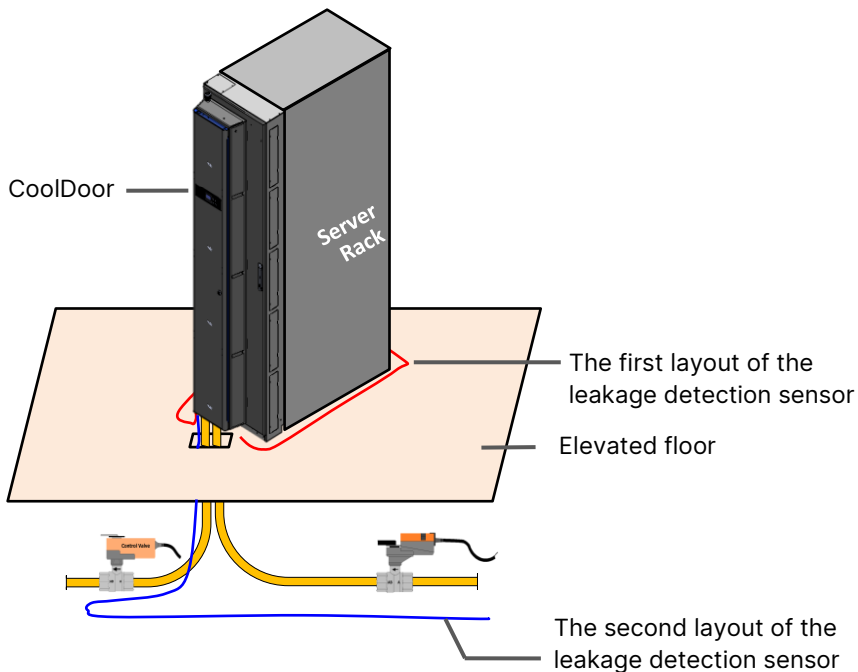

**Figure 3-17: Leakage Detection Sensor Layout**

## **3.11 Water Quality Requirements**

In order to ensure the long-term and reliable operation of the CoolDoor, water quality control must be carried out for the piping system of the CoolDoor to prevent small particles from damaging the O-rings of the components, which can lead to poor sealing, the ball valve components being unable to be operated due to deposits, or even a decrease in the heat transfer effect due to the fouling of the inner surface of the coil. Therefore, when the installation of the pipeline is completed and it is to be connected to the CoolDoor product, cleaning and flushing must be completed, and the injected water quality must be controlled.

Operations shall be complied with ASHRAE water chemistry requirements from the “Liquid Cooling Guidelines for Datacom Equipment Centers”, Second Edition, 2014, ISBN 978-1-936504-67-1, and also the designated ASHRAE-D-90564. Facility water quality index and chilled facility water system (FWS) circuit requirements are as shown in **Table 3-1**:

**Table 3-1: Water Quality**

| <b>Parameter</b>                       | <b>Recommended Limits</b> |
|--|---------------------------|
| pH                                     | 7 to 9                    |
| Corrosion inhibitor                    | Required                  |
| Sulfides                               | <10 ppm                   |
| Sulfate                                | <100 ppm                  |
| Chloride                               | <50 ppm                   |
| Bacteria                               | <1000 CFU/mL              |
| Total hardness (as CaCO <sub>3</sub> ) | <200 ppm                  |
| Residue after evaporation              | <500 ppm                  |
| Turbidity                              | <20 NTU (nephelometric)   |

In order to ensure the long-term and stable operation of the CoolDoor, use drinking water for the initial water injection for best results. Delta recommends that the chilled water system be equipped with a filter to ensure that the filtering reaches <50 microns. Delta CDU can provide a reliable chilled water system and monitor water quality; it can also provide solutions for the water quality of the closed chilled water system.

CoolDoor can use water and propylene and water and glycol mixtures as well as water treatment additives. A qualified water treatment contractor should be consulted to obtain recommendations and water quality analyses to meet your specific requirements.

For water-saving treatment, you should consult water treatment professionals for testing and inspection. Chemical treatment of the components and fluid requirements of the closed loop system are required. Content of all circulating water and supplemental water must be maintained at the best levels in accordance with industry standards. Maintain proper levels of pH, alkalinity, chloride, nitrites, and conductivity, as well as other chemicals and metals that must be tested and monitored in the system. Water quality treatment should be implemented during the initial system adjustment to provide long-term system reliability. This test is outside of the scope of this document.



**WARNING:**

Do not use deionized water (DIW) as it is corrosive to some metals.

## Chapter 4 : Wiring

### 4.1 Connect the Power Cables

- Before connecting, be sure to disconnect the external power supply and use an electric meter to confirm that the power is off.
- The input power must meet the rating shown on the equipment nameplate.



**WARNING:**

The device has two redundant power inputs, both of which must be shut off before maintenance.

Electrical services must comply with the local electrical regulations of the particular country and region. For circuit protection, refer to the requirements shown on the equipment nameplate.

Hazards from incorrect power connections may cause damage to the equipment and invalidate the warranty. Before connecting the equipment to the main power supply or backup power supply (such as a backup power generator), check to ensure that the power supply has been correctly adjusted to the voltage and frequency requirements shown on the equipment nameplate.

#### Connect the power cable (single or dual power supply)

##### Step 1

When the input is a single power supply, connect the cable with the Feed A label on its plug to the external power supply, as shown in *Figure 4-1*.

##### Step 2

When the input is dual power supply, connect the cable with the Feed A label on its plug to the external main power supply, and connect the cable with the Feed B label on its plug to the external backup power supply, as shown in *Figure 4-1*.

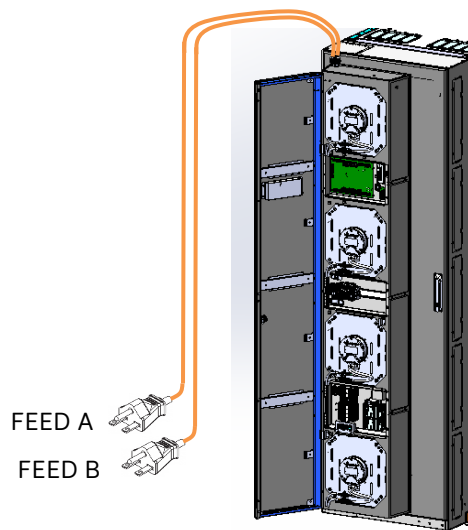

Figure 4-1: Power Cable Connection

## 4.2 Connect the Signal Cables

### Connect the signal cables (upper incoming cable)

It is suggested that you use cables with wire diameter of 22 AWG or larger, and use a suitable conduit or bushing for each cable protection.

#### Step 1

Use needle-nose pliers to remove the knockers at the top of the rack, and then take out the cable protection ring from the accessory bag. Put the protection ring on the perforated hole, as shown in *Figure 4-2*.

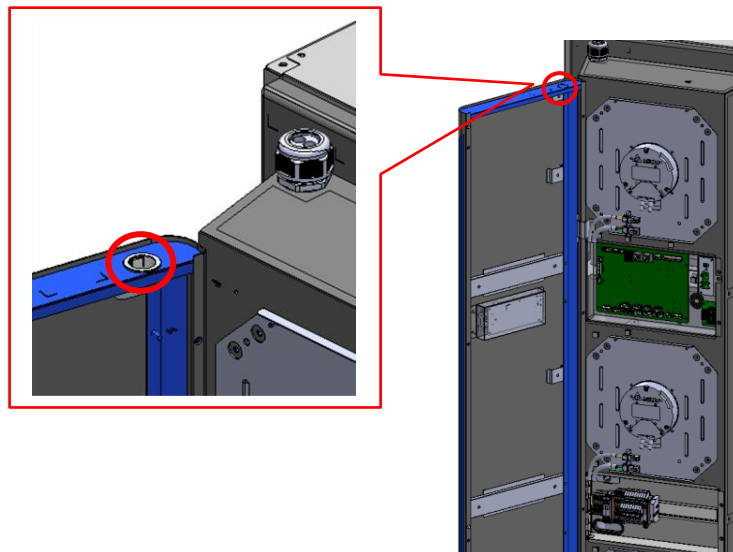

Figure 4-2: Upper Incoming Signal Cable Position

### **Step 2**

Route the signal cable through the equipment to the signal cable inlet on the top of the rack.

### **Step 3**

Push the signal cable into the hole of the signal cable inlet on the top of the rack and connect it to the terminal block in the rack, as shown in *Figure 4-3*.

### **Step 4**

Use the binding strap to fix the signal cable to the proper position in the device.

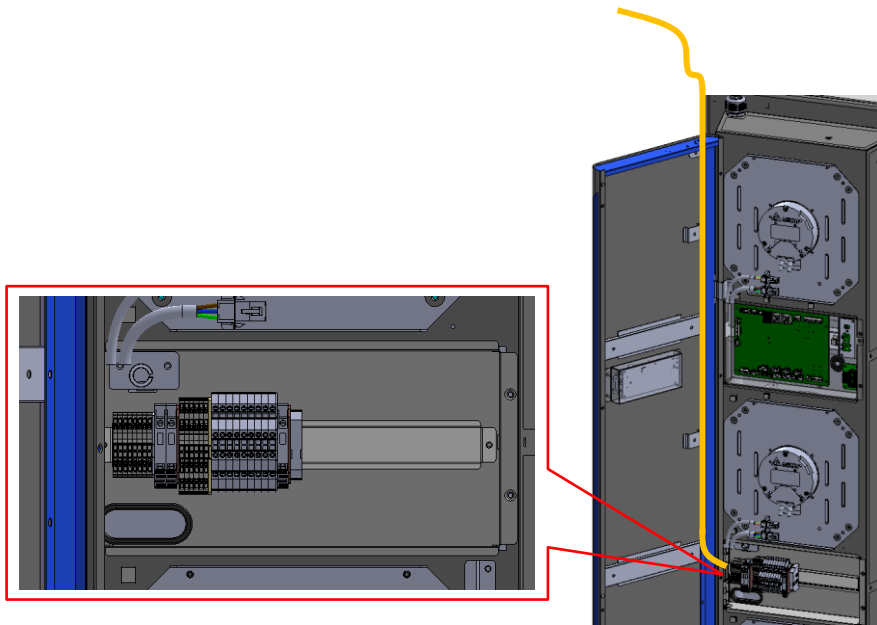

Figure 4-3: Upper Incoming Signal Cable

Connect the signal cable (lower incoming cable)

### **Step 1**

Use needle-nose pliers to remove the knockers at the bottom of the rack, and then take out the cable protection ring from the accessory bag. Put the protection ring on the perforated hole, as shown in *Figure 4-4*.

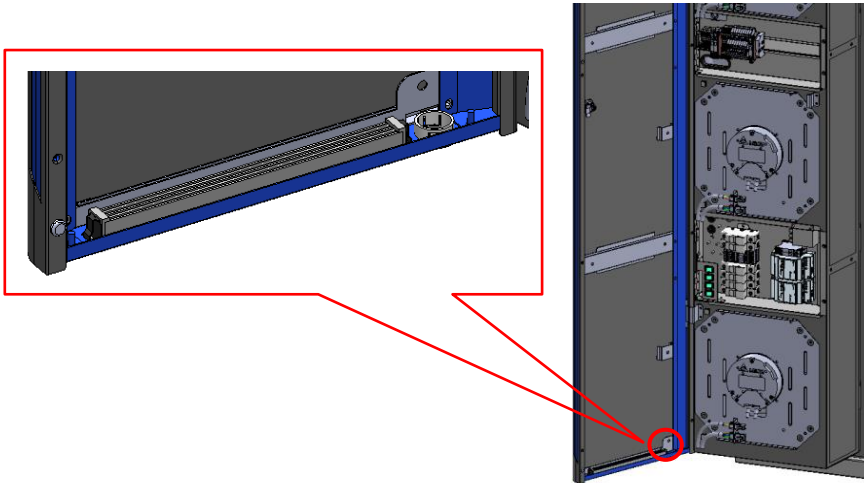

Figure 4-4: Lower Incoming Signal Cable Position

### **Step 2**

Route the signal cable through the device to the signal cable entrance at the bottom of the rack.

### **Step 3**

Push the signal cable into the hole of the signal cable inlet on the bottom of the rack and connect it to the terminal block in the rack, as shown in *Figure 4-5*.

### **Step 4**

Use the binding strap to fix the signal cable to the proper position in the device.

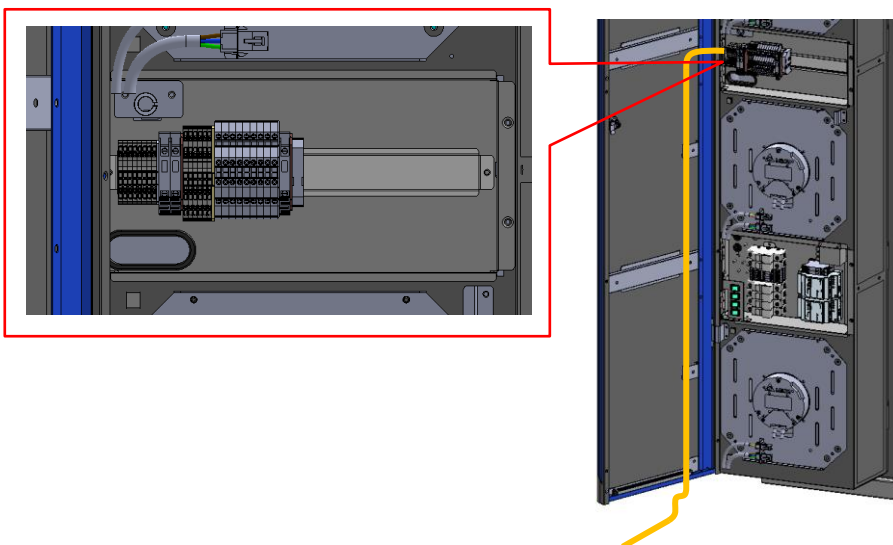

Figure 4-5: Lower Incoming Signal Cable

## 4.3 Panel Diagram

### Power panel

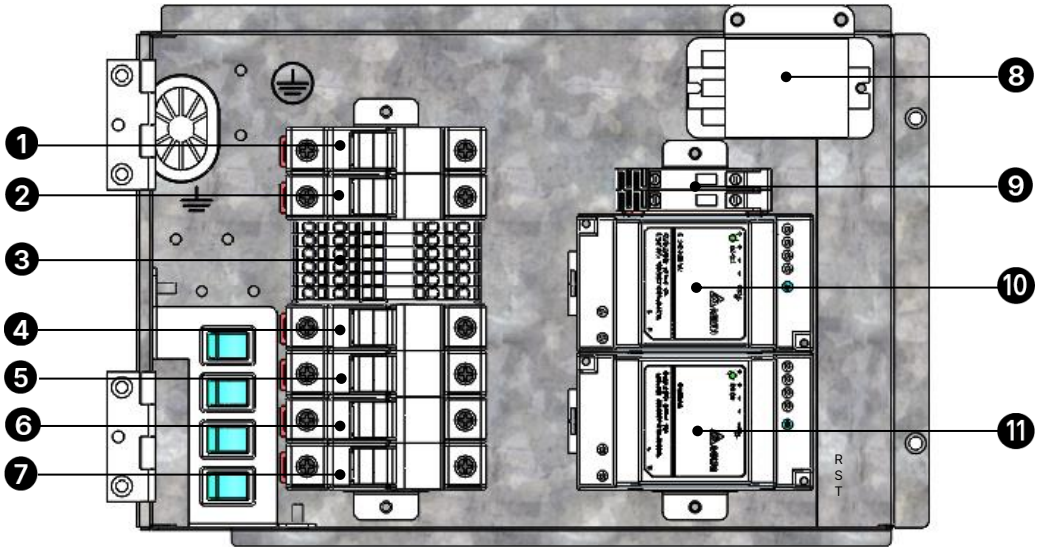

Figure 4-6: Power Control Panel Diagram

| Item | Description       | Item | Description                  |
|------|-------------------|------|------------------------------|
| ①    | Main power fuse   | ⑦    | Fan 4 power fuse             |
| ②    | Backup power fuse | ⑧    | Dual power over switch relay |
| ③    | Terminal block    | ⑨    | Power supply unit 1&2 fuse   |
| ④    | Fan 1 power fuse  | ⑩    | Power supply unit 1          |
| ⑤    | Fan 2 power fuse  | ⑪    | Power supply unit 2          |
| ⑥    | Fan 3 power fuse  | -    | -                            |

Control panel

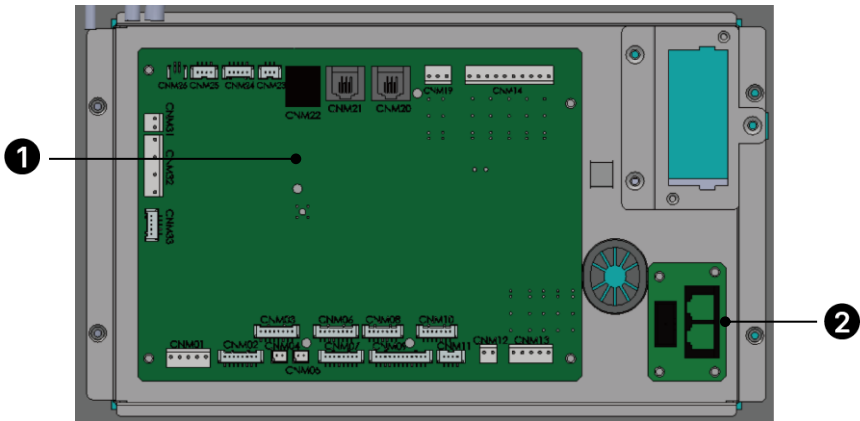

Figure 4-7: Control Panel Diagram

| Item | Description                          |
|------|--------------------------------------|
| 1    | Control board                        |
| 2    | Display & SNMP slot IO connect board |

Signal IO interface panel

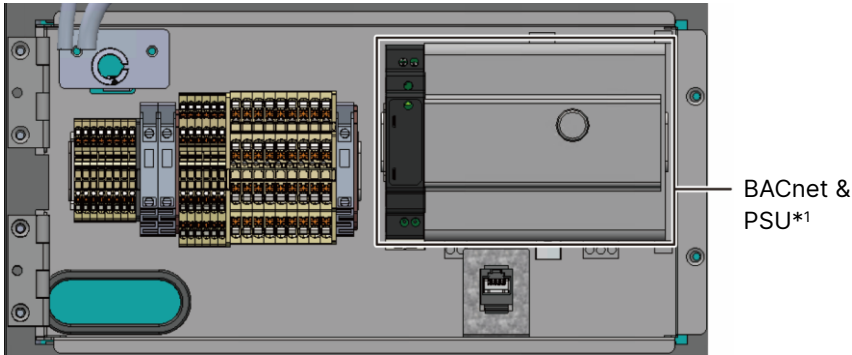

Figure 4-8: Signal Interface Panel Diagram



NOTE:

\*1 BACnet & PSU are optional accessories.

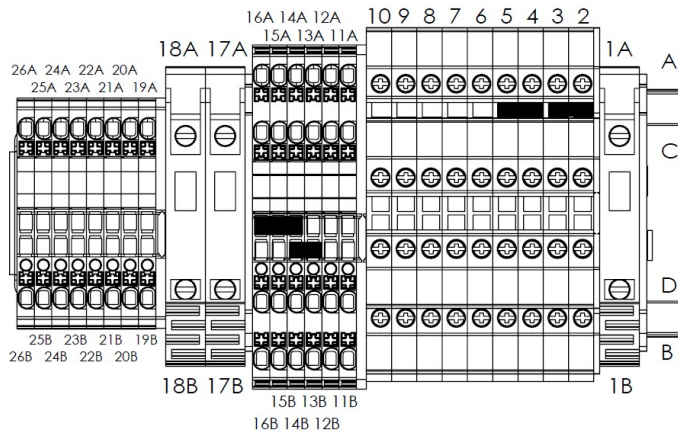

Figure 4-9: Signal Interface Contact

- X3 terminal block contacts 1–10

| Item | Description                    | Item | Description        | Item | Description                         | Item | Description                   |
|------|--------------------------------|------|--------------------|------|-------------------------------------|------|-------------------------------|
| 1A   | Power input (AC-L)             |      | N/A                |      | N/A                                 | 1B   | Power supply 3 power input    |
| 2A   | PWM 1 output                   | 2C   | Input dry contact  | 2D   | Fan 1 status feedback               | 2B   | Fan 1 speed control           |
| 3A   | PWM 1 output                   | 3C   | Input dry contact  | 3D   | Fan 2 status feedback               | 3B   | Fan 2 speed control           |
| 4A   | PWM 2 output                   | 4C   | Input dry contact  | 4D   | Fan 3 status feedback               | 4B   | Fan 3 speed control           |
| 5A   | PWM 2 output                   | 5C   | Input dry contact  | 5D   | Fan 4 status feedback               | 5B   | Fan 4 speed control           |
| 6A   | Analog digital converter input | 6C   | 0-10VDC input      | 6D   | Differential pressure sensor status | 6B   | Water leakage detection       |
| 7A   | 0-10VDC output                 | 7C   | 2-10VDC input      | 7D   | Control valve opening feedback      | 7B   | Control valve opening control |
| 8A   | Digital input frequency        | 8C   | Output dry contact | 8D   | Solenoid valve switch control       | 8B   | Flow meter status feedback    |

| Item | Description        | Item | Description        | Item | Description                  | Item | Description                   |
|------|--------------------|------|--------------------|------|------------------------------|------|-------------------------------|
| 9A   | 12VDC output       | 9C   | Output dry contact | 9D   | Light bar-red light control  | 9B   | Light bar-power supply        |
| 10A  | Output dry contact | 10C  | Output dry contact | 10D  | Light bar-blue light control | 10B  | Light bar-green light control |

- X3 terminal block contacts 11–18

| Item | Description                        | Item | Description                                   | Item | Description                | Item | Description                              |
|------|------------------------------------|------|---|------|----------------------------|------|--|
| 11A  | Power input (24VDC)                | 11A  | Power output (24VDC)                          | 11B  | Solenoid valve power input | 11B  | Differential pressure sensor power input |
| 12A  | Power input (12VDC)                | 12A  | Power output (12VDC)                          | 12B  | N/A                        | 12B  | Flow meter power input                   |
| 13A  | Power GND                          | 13A  | Flow meter power supply GND                   | 13B  | Remote switch (COM)        | 13B  | Fan 1 signal GND                         |
| 14A  | Light bar (red) power GND          | 14A  | Solenoid valve power supply GND               | 14B  | Fire and smoke alarm (COM) | 14B  | Fan 2 signal GND                         |
| 15A  | Light bar (green) power supply GND | 15A  | Water leakage detection signal GND            | 15B  | Control valve signal GND   | 15B  | Fan 3 signal GND                         |
| 16A  | Light bar (blue) power supply GND  | 16A  | Differential pressure sensor power supply GND | 16B  | BACnet power supply GND    | 16B  | Fan 4 signal GND                         |
| 17A  | 24VDC input                        |      | N/A   |      | N/A                        | 17B  | Control valve power input                |
| 18A  | 24VDC input                        |      | N/A   |      | N/A                        | 18B  | Solenoid valve power input               |

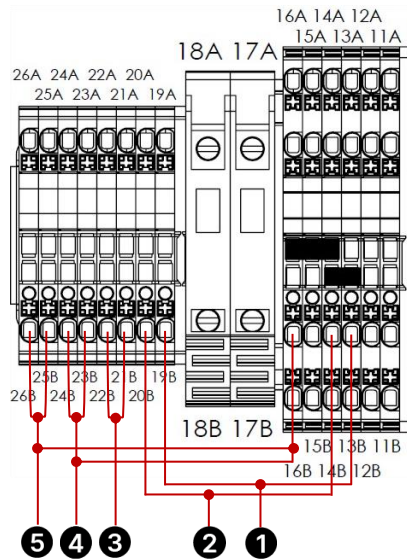

Figure 4-10: External Signal Interface Contact

- X3 terminal block contacts 19–26

Suggest using cables with wire diameter of 22 AWG or larger and connecting the cables to user-supplied cord end terminals. The length of each terminal must be 12 mm.

| No | Item                              | Description  | Cable     |
|----|-----------------------------------|--|-----------|
| ①  | Input dry contact (Remote On/Off) | Normally open state; connect the remote switch device. When the switch is activated, the dry contact device triggers a short circuit, and the system will record it in the event log.  | 22 AWG 2C |
| ②  | Input dry contact (Fire Alarm)    | Normally open state; connect fire alarm or smoke detector. When an event occurs, the dry contact device triggers a short circuit, which the system will record in the event log, and the buzzer and FAULT indicator light will be activated. | 22 AWG 2C |
| ③  | Output Dry Contacts               | Normally open state; connect the dry contact device to this port; the device will be triggered when the system alarm event occurs (the loop is closed).  | 22 AWG 2C |
| ④  | RS485 contact                     | The RS485 contact allows you to connect to a workstation or BACnet for remote operation through the MODBUS protocol.<br>23B (D+) , 24B(D-), 16B (GND)  | 22 AWG 3C |
| ⑤  | CAN-Link contact                  | CAN-Link contacts allow you to use one-in, one-out serial connection configuration for group control.<br>25B (CAN-H), 26B (CAN-L), 16B (GND)   | 22 AWG 3C |

## Chapter 5 : Initial Start-up

### 5.1 Inspection Prior to Activation



**WARNING:**

Only qualified service staff may perform the installation steps hereunder.



**WARNING:**

This equipment contains high voltage that can be fatal! Make sure that the power is disconnected before you perform the following.



**WARNING:**

Arbitrary startup without correctly finishing the inspection prior to startup as indicated in 4.1 can lead to serious personal injuries or damage to the equipment.

Please finish all of the inspections prior to the initial activation of the program.

#### Inspection Checklist

---

##### General

- There is no damage to the surroundings of the device.
- Device positioning is finished.
- The installation has been completed in compliance with ***Section 3: Installation Instructions***.
- Piping inside and outside the cabinet has been correctly connected. The insulation layer of the pipeline is free of signs of impairment or leakage.
- The access door is in place and the console cable is re-connected.

---

##### Environmental Protection

- The indoor environment is a closed space isolated from interference of external temperature and humidity.
- The clearance in the surroundings of the cabinet meets requirements (See ***3.2 Clearance***).
- Correct environmental humidity (See ***5.2 Operating Temperature & Humidity***).

---

##### Electronic Connection

- The rated value of input power is identical to that marked on the nameplate.
  - The equipment has been properly earthed.
-

- 
- All electronic connections are tightly secure.
- 
- Remote temperature (humidity) sensors have been correctly connected and set up in appropriate locations.
- 
- The water leakage testing line has been correctly deployed.
- 

### **Mechanical Connection**

---

- The pipes and valves are free of rupture or damage.
- 
- Is the control valve/electric shut-off valve installed and is the wiring correct?
- 
- Is the flow meter installed and is the wiring correct?
- 
- The temperature of external water supply is steady.
- 
- The external water supply pressure is correct.
- 

## **5.2 Operating Temperature & Humidity**

Use auxiliary dehumidification equipment or air conditioners to adjust the indoor temperature and humidity when setting up the equipment room. When applied to low load conditions and high humidity conditions, use auxiliary dehumidification equipment to adjust the humidity.



### **WARNING:**

If the indoor humidity is too high and the chilled water temperature is too low, condensation around the coil may generate too much condensate, which will lead to leakage on the indoor floor. Ensure that the chilled water temperature is always higher than the dew point temperature of the indoor environment.

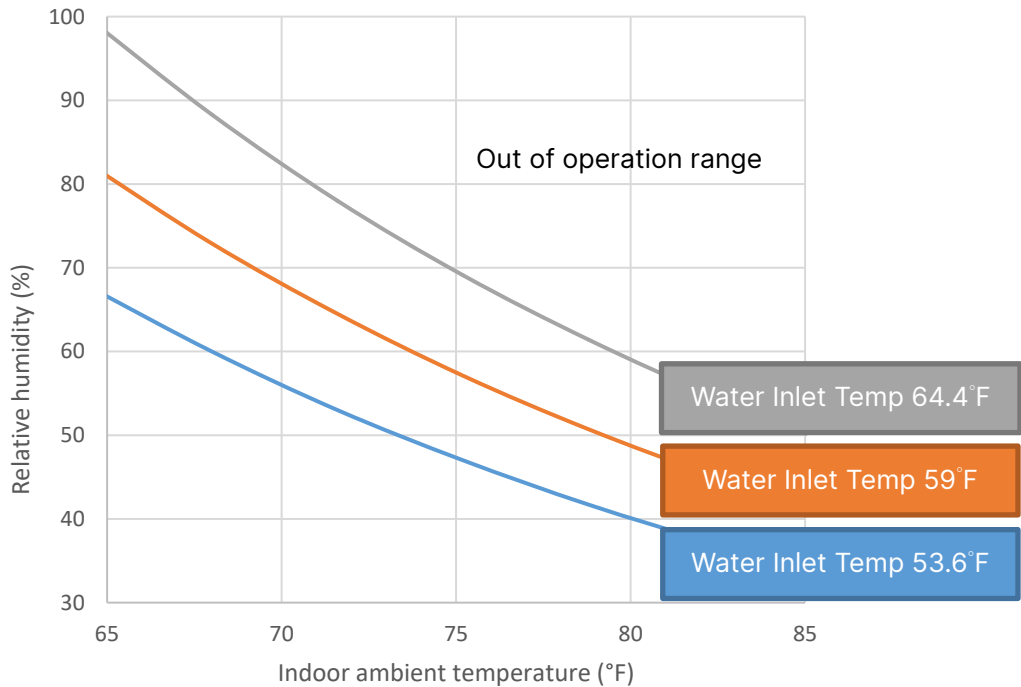

### 5.3 Power Supply

Please supply power to the cooling device. With power supply, it enters the standby mode automatically. For safety reason, the fan will not run automatically. With the power supply connected to the system, the read screen appears on the touch display and status page shows up spontaneously.

|                                 |
|---------------------------------|
| <b>Air state</b>                |
| 26.3°C                          |
| <b>Percentage of air volume</b> |
| 100%                            |

Figure 5-1: Status Page

For how to interpret the values shown on the status page and the operation, refer to **5. Operation**.

## 5.4 Ventilation



### WARNING:

When performing this installation step, ensure the safety of personnel. Wear protective gear, especially goggles to protect the eyes, to prevent impact from water stream.

The following steps can help check that the system pressure supply is normal. Use a stable pressure supply to remove air from the closed chilled water system. Part of the air accumulated in the coil can also be removed by following the steps below. The following actions can only remove the air in the coil of the CoolDoor, and cannot ensure that the air in the closed chilled water system is completely removed. The air release valve should be used for automatic exhaust at the highest and most reasonable point of the closed circuit system.

1. It is recommended that the tool filling soft tube should be equipped with a refill tool that has a switch; the connection size of the exhaust valve is 7/16", as shown in the figure on the right.



2. When making adjustments, the closed chilled water circuit should be in operation. Find the position of the exhaust valve on the CoolDoor, as shown in the figure below. Turn the cap to the right, and install the filling soft tube inlet with a switch on the position of the exhaust valve on the CoolDoor, as shown in the figure below. Connect the pressure gauge to the outlet of the filling soft tube.

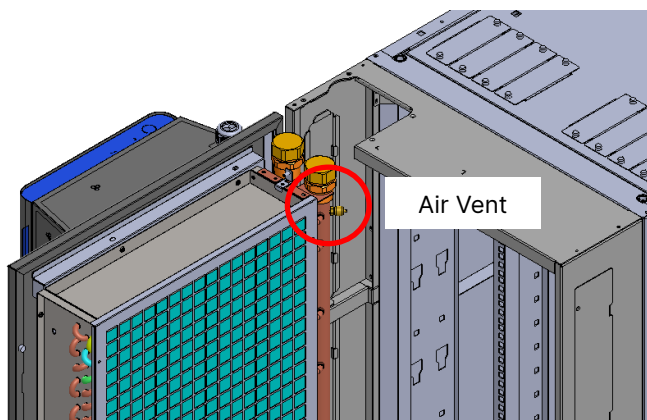

3. Turn on the switch of the filling soft tube to confirm that operating pressure is normal.

4. The filling soft tube switch is closed, the pressure gauge is removed, the filling soft tube is directed into the water bucket, and the filling soft tube switch is turned on to perform air removal. Continue until the air is completely discharged, and only when the liquid working fluid is completely discharged can it be closed.
5. Remove the filling soft tube and cover with the cap. Make sure that the cap is tight and that there is no leakage.
6. The above actions are performed on the CoolDoor on site.

## 5.5 Water Volume Equilibrium

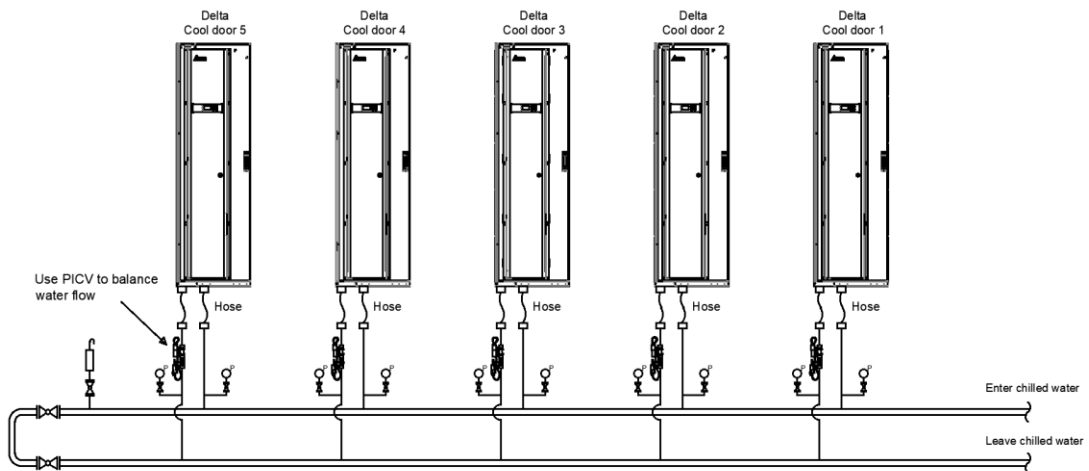

If the main pipeline pressure drop is high, or the distance between the individual CoolDoors is relatively long, it is easy to cause water imbalance. Unbalanced water volume can easily cause insufficient water volume at the last of the CoolDoor; or when controlled by a 2-way control valve, it can cause drastic changes in the water volume of other CoolDoors, which will make the overall waterway system unstable.

Delta recommends using pressure independent control valve, which can achieve the water balance function, without TAB adjustment and through precise flow control methods, the water volume of each CoolDoor system can be completely controlled independently.



### NOTE:

Since the main pipeline design is not Delta's design and the Delta's CoolDoor adopts a 2-way control valve, Delta cannot guarantee the CoolDoor system water balance.

# Chapter 6 : Operation

## 6.1 Menu Tree

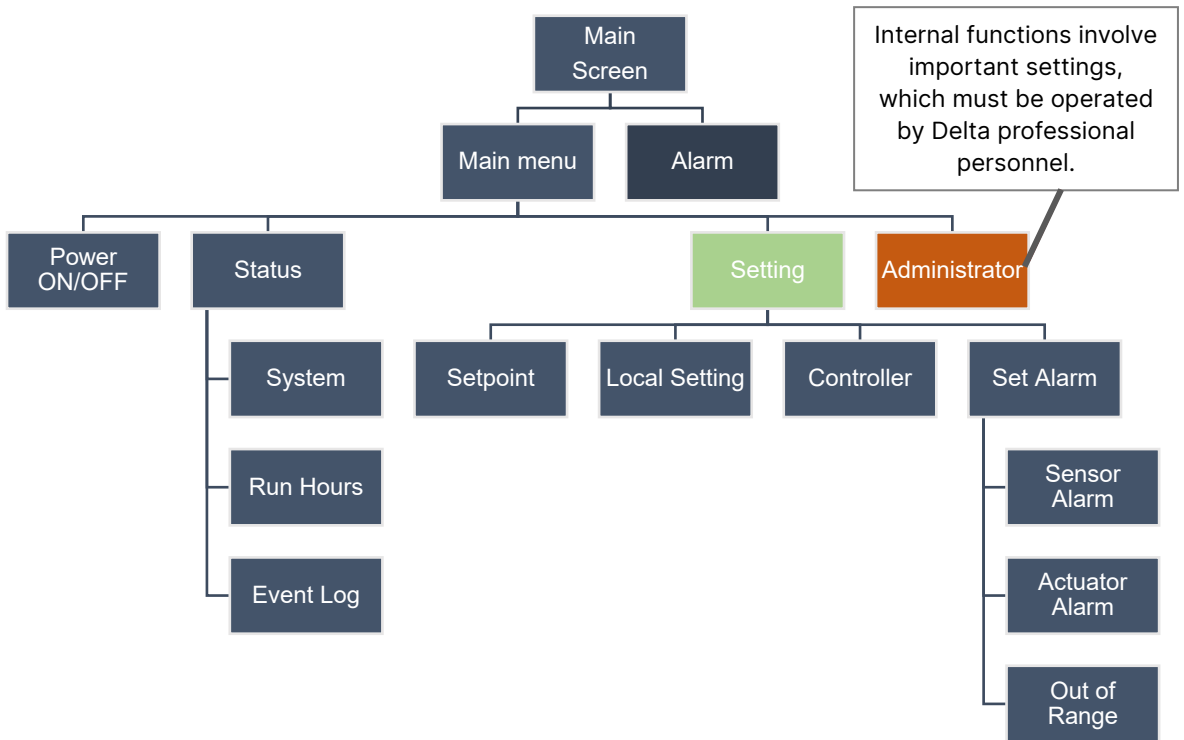

## 6.2 Control Panel











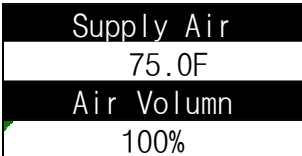
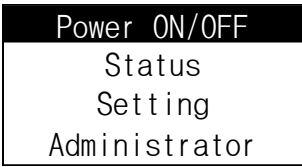

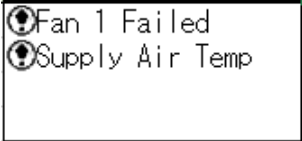
| Panel Label    | Function Description   |
|----------------|--|
| <b>MAIN ON</b> | When the green light is on, it means there is power supply. If the light flashes, it means it is in installation mode. |
| <b>STANDBY</b> | When the yellow light is on, it means it is in standby mode.   |
| <b>WARNING</b> | When the yellow light is on, it means there is an alarm message.   |
| <b>FAULT</b>   | When the red light is on, it means there is a fault message.   |
| <b>▲▼</b>      | 1. Page up or down.<br>2. Move the highlighted area or select a character code.  |
| <b>ESC</b>     | Return to the previous screen or stop the current operation.   |
| <b>⏎</b>       | Enter selected option or confirm settings.   |

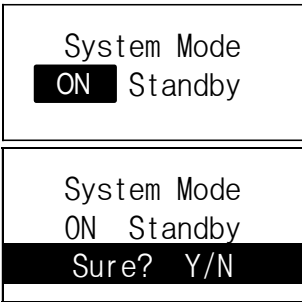
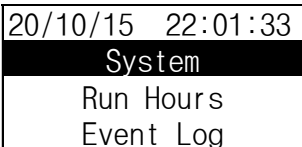





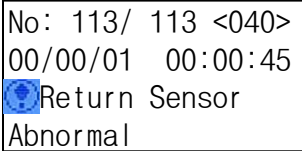

## 6.3 Status Page Operation

### Read screen:

The following are not actual display screens

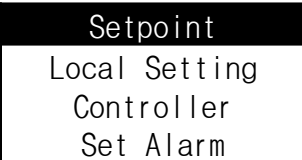
|                            |   |   |
|----------------------------|---|---|
| <p><b>Main Screen</b></p>  |    | <p>The first page entered after the boot is complete; this page immediately displays important information. If you want to go to this screen, use ESC on any page to return to this page.</p>   |
| <p><b>Main menu</b></p>    |    | <p>Press  key to enter the Main Menu.</p> <p>The black box is the item currently selected by the user, from which  can be selected.</p> <p>Option content</p> <ol style="list-style-type: none"> <li>1. Power ON/OFF</li> <li>2. Status</li> <li>3. Setting</li> <li>4. Administrator</li> </ol>    |
| <p><b>Alarm</b></p>        |   | <p>On the Main Screen, press   key to enter and view.</p>   |
| <p><b>Power ON/OFF</b></p> |  | <p>Select Enable and Standby on this page. Selecting ON will make the CoolDoor start running; it will be automatically controlled according to IT Rack heat load and the set temperature. If Standby is selected, the CoolDoor will stop the operation of the fan and ball valve and maintain the standby state.</p> <p>When you select ON or Standby, you will be asked whether to execute it. If you want to execute, select Y; if not, select N.</p>                 |
| <p><b>Status</b></p>       |  | <p>When you enter Status, you will come to this menu, where the current time will be displayed at the top (can be set through the setting page).</p> <p>Use   option, option content:</p> <ol style="list-style-type: none"> <li>1. System</li> <li>2. Run Hours</li> <li>3. Event Log</li> </ol> |

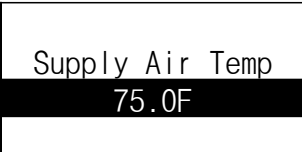
|                    |  |                   |                   |                   |                   |                 |                 |                  |   |                  |                   |                |                 |                  |                   |                   |                    |                   |                   |  |
|--------------------|--|-------------------|-------------------|-------------------|-------------------|-----------------|-----------------|------------------|---|------------------|-------------------|----------------|-----------------|------------------|-------------------|-------------------|--------------------|-------------------|-------------------|--|
| <b>System</b>      | <table border="1" style="width: 100%; border-collapse: collapse;"> <tr> <td style="padding: 2px;">Supply Air T: 75F</td> </tr> <tr> <td style="padding: 2px;">Return AirT1: 75F</td> </tr> <tr> <td style="padding: 2px;">Return AirT2: 75F</td> </tr> <tr> <td style="padding: 2px;">Return AirT3: 75F</td> </tr> <tr> <td style="padding: 2px;">Power Source: A</td> </tr> <tr> <td style="padding: 2px;">BV Command : 0%</td> </tr> <tr> <td style="padding: 2px;">BV Feedback : 0%</td> </tr> <tr> <td style="padding: 2px;">Fan Command :100%</td> </tr> <tr> <td style="padding: 2px;">Water In T : 53F</td> </tr> <tr> <td style="padding: 2px;">Water Out T : 62F</td> </tr> <tr> <td style="padding: 2px;">Remote T : 75F</td> </tr> <tr> <td style="padding: 2px;">Remote DP : 60F</td> </tr> <tr> <td style="padding: 2px;">RA Pressure: 0Pa</td> </tr> <tr> <td style="padding: 2px;">Water Flow : 0GPM</td> </tr> <tr> <td style="padding: 2px;">Fire Cut-off : ON</td> </tr> <tr> <td style="padding: 2px;">Leak Detection: ON</td> </tr> <tr> <td style="padding: 2px;">Turbo boost : OFF</td> </tr> <tr> <td style="padding: 2px;">Auto Recover : ON</td> </tr> </table> | Supply Air T: 75F | Return AirT1: 75F | Return AirT2: 75F | Return AirT3: 75F | Power Source: A | BV Command : 0% | BV Feedback : 0% | Fan Command :100%   | Water In T : 53F | Water Out T : 62F | Remote T : 75F | Remote DP : 60F | RA Pressure: 0Pa | Water Flow : 0GPM | Fire Cut-off : ON | Leak Detection: ON | Turbo boost : OFF | Auto Recover : ON | <p><b>Main menu → Status → System</b>, press  key to enter.</p> <p>The system status page can help users obtain various sensor information and power status, ball valve status, fan commands, and important setting parameters. Corresponding options that are not installed will be displayed as "--". Due to the large number of displayed data, you can use   to view the full details.</p> |
| Supply Air T: 75F  |  |                   |                   |                   |                   |                 |                 |                  |   |                  |                   |                |                 |                  |                   |                   |                    |                   |                   |  |
| Return AirT1: 75F  |  |                   |                   |                   |                   |                 |                 |                  |   |                  |                   |                |                 |                  |                   |                   |                    |                   |                   |  |
| Return AirT2: 75F  |  |                   |                   |                   |                   |                 |                 |                  |   |                  |                   |                |                 |                  |                   |                   |                    |                   |                   |  |
| Return AirT3: 75F  |  |                   |                   |                   |                   |                 |                 |                  |   |                  |                   |                |                 |                  |                   |                   |                    |                   |                   |  |
| Power Source: A    |  |                   |                   |                   |                   |                 |                 |                  |   |                  |                   |                |                 |                  |                   |                   |                    |                   |                   |  |
| BV Command : 0%    |  |                   |                   |                   |                   |                 |                 |                  |   |                  |                   |                |                 |                  |                   |                   |                    |                   |                   |  |
| BV Feedback : 0%   |  |                   |                   |                   |                   |                 |                 |                  |   |                  |                   |                |                 |                  |                   |                   |                    |                   |                   |  |
| Fan Command :100%  |  |                   |                   |                   |                   |                 |                 |                  |   |                  |                   |                |                 |                  |                   |                   |                    |                   |                   |  |
| Water In T : 53F   |  |                   |                   |                   |                   |                 |                 |                  |   |                  |                   |                |                 |                  |                   |                   |                    |                   |                   |  |
| Water Out T : 62F  |  |                   |                   |                   |                   |                 |                 |                  |   |                  |                   |                |                 |                  |                   |                   |                    |                   |                   |  |
| Remote T : 75F     |  |                   |                   |                   |                   |                 |                 |                  |   |                  |                   |                |                 |                  |                   |                   |                    |                   |                   |  |
| Remote DP : 60F    |  |                   |                   |                   |                   |                 |                 |                  |   |                  |                   |                |                 |                  |                   |                   |                    |                   |                   |  |
| RA Pressure: 0Pa   |  |                   |                   |                   |                   |                 |                 |                  |   |                  |                   |                |                 |                  |                   |                   |                    |                   |                   |  |
| Water Flow : 0GPM  |  |                   |                   |                   |                   |                 |                 |                  |   |                  |                   |                |                 |                  |                   |                   |                    |                   |                   |  |
| Fire Cut-off : ON  |  |                   |                   |                   |                   |                 |                 |                  |   |                  |                   |                |                 |                  |                   |                   |                    |                   |                   |  |
| Leak Detection: ON |  |                   |                   |                   |                   |                 |                 |                  |   |                  |                   |                |                 |                  |                   |                   |                    |                   |                   |  |
| Turbo boost : OFF  |  |                   |                   |                   |                   |                 |                 |                  |   |                  |                   |                |                 |                  |                   |                   |                    |                   |                   |  |
| Auto Recover : ON  |  |                   |                   |                   |                   |                 |                 |                  |   |                  |                   |                |                 |                  |                   |                   |                    |                   |                   |  |
| <b>Run Hours</b>   | <table border="1" style="width: 100%; border-collapse: collapse;"> <tr> <td style="padding: 2px;">System : 0h</td> </tr> <tr> <td style="padding: 2px;">Fan 1 : 0h</td> </tr> <tr> <td style="padding: 2px;">Fan 2 : 0h</td> </tr> <tr> <td style="padding: 2px;">Fan 3 : 0h</td> </tr> <tr> <td style="padding: 2px;">Fan 4 : 0h</td> </tr> <tr> <td style="padding: 2px;">Fan 5 : 0h</td> </tr> <tr> <td style="padding: 2px;">Ball Valve: 0h</td> </tr> </table>  | System : 0h       | Fan 1 : 0h        | Fan 2 : 0h        | Fan 3 : 0h        | Fan 4 : 0h      | Fan 5 : 0h      | Ball Valve: 0h   | <p><b>Main menu → Status → Run Hours</b>, press  key to enter.</p> <p>CoolDoor will record the running time of the system, and record the running time of the fan and the ball valve. If important components stop operating due to abnormalities, the time will not be recorded. This helps the user analyze the continuous running status of the system.</p> |                  |                   |                |                 |                  |                   |                   |                    |                   |                   |  |
| System : 0h        |  |                   |                   |                   |                   |                 |                 |                  |   |                  |                   |                |                 |                  |                   |                   |                    |                   |                   |  |
| Fan 1 : 0h         |  |                   |                   |                   |                   |                 |                 |                  |   |                  |                   |                |                 |                  |                   |                   |                    |                   |                   |  |
| Fan 2 : 0h         |  |                   |                   |                   |                   |                 |                 |                  |   |                  |                   |                |                 |                  |                   |                   |                    |                   |                   |  |
| Fan 3 : 0h         |  |                   |                   |                   |                   |                 |                 |                  |   |                  |                   |                |                 |                  |                   |                   |                    |                   |                   |  |
| Fan 4 : 0h         |  |                   |                   |                   |                   |                 |                 |                  |   |                  |                   |                |                 |                  |                   |                   |                    |                   |                   |  |
| Fan 5 : 0h         |  |                   |                   |                   |                   |                 |                 |                  |   |                  |                   |                |                 |                  |                   |                   |                    |                   |                   |  |
| Ball Valve: 0h     |  |                   |                   |                   |                   |                 |                 |                  |   |                  |                   |                |                 |                  |                   |                   |                    |                   |                   |  |

|                         |   |  |
|-------------------------|---|--|
| <p><b>Event Log</b></p> |    | <p><b>Main menu</b> → <b>Status</b> → <b>Event Log</b>, press  key to enter.</p> <p>The event log will record important events that have occurred, such as power on and off or the generation of alarms.</p> <p>The No: XXX/XXX above indicates the order of events, &lt;XXX&gt; represents the event code, the time is in YY/MM/DD hh:mm:ss, and the event name is displayed to the side of .</p> <p> <b>NOTE:</b><br/>The maximum number of Event Log display items is 200.</p> |
| <p><b>Setting</b></p>   |    | <p><b>Main menu</b> → <b>Setting</b>, press  key to enter.</p> <p>This page can be used by customers to make settings according to their needs. For details, please refer to the description below.</p> <p>Option content:</p> <ol style="list-style-type: none"> <li>1. Setpoint</li> <li>2. Local Setting</li> <li>3. Controller</li> <li>4. Set Alarm</li> </ol>   |
| <p><b>Setpoint</b></p>  |  | <p><b>Main menu</b> → <b>Setting</b> → <b>Setpoint</b>, press  key to enter.</p> <p>This setting determines the outlet air temperature target and compares with the outlet air temperature configured value and IT Rack to calculate the control parameters of the ball valve opening.</p>  |

|   |   |          |          |       |              |          |             |           |           |  |
|---|---|----------|----------|-------|--------------|----------|-------------|-----------|-----------|--|
| <b>Local Setting</b>  | <table border="1" style="width: 100%; border-collapse: collapse;"> <tr style="background-color: #333; color: white;"> <td style="text-align: left;">00/01/01</td> <td style="text-align: right;">00:00:00</td> </tr> <tr> <td>ID</td> <td style="text-align: right;">:01</td> </tr> <tr> <td>Contrast</td> <td style="text-align: right;">:2</td> </tr> <tr> <td>Baud Rate</td> <td style="text-align: right;">: 9600</td> </tr> </table> | 00/01/01 | 00:00:00 | ID    | :01          | Contrast | :2          | Baud Rate | : 9600    | <p><b>Main menu → Setting → Local Setting</b>, press  key to enter.</p> <p>This page is for the configuration of the following items</p> <ol style="list-style-type: none"> <li>1. YY/MM/DD hh:mm:ss: By setting to the current time, future event logs and alarms... etc. can be displayed according to the time set by the user.</li> <li>2. ID: The serial number of this device (1–99), default value is 01.</li> <li>3. Contrast: Adjust the display contrast.</li> <li>4. Baud Rate: The default value is 9600.</li> <li>5. Language: Select language for screen display; the default value is English.</li> <li>6. User PW: Modify user password.</li> <li>7. Display Unit: The user can choose units according to their region: BS British system/ MS metric system.</li> <li>8. Total Alarm: Delta CoolDoor design dry contact output; you can use this status point for assistance, and notify the host computer function according to the severity of the CoolDoor system. This setting can perform dry contact status transition according to different levels, and set All alarms to status transition/Major severe alarms to status transition. Default value is Major</li> <li>9. Remote ON: Provides remote control switch function; when it is turned on, remote authority is greater than the local end.</li> </ol> |
|   | 00/01/01  | 00:00:00 |          |       |              |          |             |           |           |  |
| ID  | :01   |          |          |       |              |          |             |           |           |  |
| Contrast  | :2  |          |          |       |              |          |             |           |           |  |
| Baud Rate   | : 9600  |          |          |       |              |          |             |           |           |  |
| <table border="1" style="width: 100%; border-collapse: collapse;"> <tr> <td>Language</td> <td style="text-align: right;">:EN</td> </tr> <tr> <td>User PW</td> <td style="text-align: right;">:----</td> </tr> <tr> <td>Display Unit</td> <td style="text-align: right;">:BS</td> </tr> <tr> <td>Total Alarm</td> <td style="text-align: right;">:Major</td> </tr> </table><br><table border="1" style="width: 100%; border-collapse: collapse;"> <tr> <td>Remote ON</td> <td style="text-align: right;">:No</td> </tr> </table> | Language  | :EN      | User PW  | :---- | Display Unit | :BS      | Total Alarm | :Major    | Remote ON | :No  |
| Language  | :EN   |          |          |       |              |          |             |           |           |  |
| User PW   | :----   |          |          |       |              |          |             |           |           |  |
| Display Unit  | :BS   |          |          |       |              |          |             |           |           |  |
| Total Alarm   | :Major  |          |          |       |              |          |             |           |           |  |
| Remote ON   | :No   |          |          |       |              |          |             |           |           |  |



## Controller

|                    |
|--------------------|
| BV P Gain : 7.70   |
| BV I Time :0.007   |
| Min Fan Temp: 68F  |
| Max Fan Temp: 113F |
| Fan P Gain : 6.00  |
| Fan I Time :0.100  |
| Min Fan Speed: 40% |
| Leak. BV-Off :OFF  |
| Auto Recover :ON   |
| Turbo boost :ON    |
| LED light Bar:ON   |
| Fire. Cut Off:ON   |

**Main menu → Setting → Controller**, press  key to enter.

This page is set for the following items. The relevant ball valve and fan PI settings (items 1–7) should be adjusted by Delta personnel. Self-adjustment will cause the CoolDoor system to become unstable.

1. BV P Gain: The ball valve will calculate different loads according to the set air temperature; the adjustment method will be controlled according to the set ratio P.
2. BV I Gain: The ball valve will perform different load calculations based on the set air outlet temperature; the adjustment method will be controlled based on the set integral time I.
3. Min Fan Temp: The temperature point corresponding to 0% fan speed.
4. Min Fan Temp: The temperature point corresponding to 100% fan speed.
5. Fan P Gain: Pressure control can be chosen for fan accessories. The fan controls the air volume according to the pressure between the IT Rack and CoolDoor, and the adjustment method is controlled according to the proportional P.
6. Fan I Gain: The fan accessories can choose pressure control, the fan controls the air volume according to the pressure between the IT Rack and CoolDoor, and the adjustment method is controlled according to the integral time I.
7. Min Fan Speed: The minimum fan speed, even without any load, will still run at the lowest speed.
8. Leak. BV-OFF: When ON is selected, and the Leak Detection Sensor detects water leakage, the ball valve and Shut Off Valve (optional) will be closed at the same time to avoid worsening of the leakage.

|                            |   |  |
|----------------------------|---|--|
| <p><b>Controller</b></p>   | <div style="border: 1px solid black; padding: 5px;"> <p>BV P Gain : 7.70<br/> BV I Time : 0.007<br/> Min Fan Temp: 68F<br/> Max Fan Temp: 113F<br/> Fan P Gain : 6.00<br/> Fan I Time : 0.100<br/> Min Fan Speed: 40%</p> <hr/> <p>Leak. BV-Off :OFF<br/> Auto Recover :ON<br/> Turbo boost :ON</p> <hr/> <p>LED light Bar:ON<br/> Fire. Cut Off:ON</p> </div>                                  | <p>9. Auto Recover: When ON is selected, after the CoolDoor suffers a complete power outage, the power will recover and still maintain the working mode before the power outage.</p> <p>10. Turbo boost: When ON is selected, the mutual backup mode provided by Delta CoolDoor is activated. When the ball valve or fan is abnormal during operation, it will be supported by the surrounding CoolDoors.</p> <p>11. LED Light Bar: You can turn on or turn off the Light Bar function below.</p> <p>12. Fire. Cut-Off: When ON is selected, and the CoolDoor fire and smoke dry contact receives a status transition signal, the CoolDoor will execute the standby state, and the fan and ball valve will be completely closed.</p> |
| <p><b>Set Alarm</b></p>    | <div style="border: 1px solid black; padding: 5px;"> <p style="text-align: center;"><b>Sensor Alarm</b></p> <p>Actuator Alarm<br/> Out of Range</p> </div>  | <p><b>Main menu → Setting → Set Alarm</b>, press  key to enter.</p> <p>This page can be used by customers to set Alarms according to their needs</p> <p>Select content:</p> <ol style="list-style-type: none"> <li>1. Sensor Alarm</li> <li>2. Actuator Alarm</li> <li>3. Out of Range</li> </ol>   |
| <p><b>Sensor Alarm</b></p> | <div style="border: 1px solid black; padding: 5px;"> <p><b>Leak SEN. : High</b></p> <p>Water Inlet T: <input checked="" type="checkbox"/><br/> Water Outlet T: <input checked="" type="checkbox"/><br/> Remote Sensor : <input checked="" type="checkbox"/></p> <hr/> <p>Condensation : <input checked="" type="checkbox"/><br/> Fire Detection: <input checked="" type="checkbox"/></p> </div> | <p><b>Main menu → Setting → Set Alarm → Sensor Alarm</b>, press  key to enter.</p> <p>The sensor alarm page can be adjusted by the user, as described below</p> <ol style="list-style-type: none"> <li>1. Leak SEN: The sensitivity of the Leak Detection Sensor can be set; selection is off/low/medium/high</li> <li>2. Water Inlet: You can choose whether to produce an alarm when the inlet water temperature sensor is abnormal.</li> </ol>   |

|   |  |  |  |   |   |  |   |   |
|---|--|--|--|---|---|--|---|---|
| <p><b>Sensor Alarm</b></p>                          | <table border="1"> <tr> <td>Leak SEN. : High</td> </tr> <tr> <td>Water Inlet T: <input checked="" type="checkbox"/></td> </tr> <tr> <td>Water Outlet T: <input checked="" type="checkbox"/></td> </tr> <tr> <td>Remote Sensor : <input checked="" type="checkbox"/></td> </tr> <tr> <td>Condensation : <input checked="" type="checkbox"/></td> </tr> <tr> <td>Fire Detection: <input checked="" type="checkbox"/></td> </tr> </table> | Leak SEN. : High                                 | Water Inlet T: <input checked="" type="checkbox"/> | Water Outlet T: <input checked="" type="checkbox"/> | Remote Sensor : <input checked="" type="checkbox"/> | Condensation : <input checked="" type="checkbox"/> | Fire Detection: <input checked="" type="checkbox"/> | <ol style="list-style-type: none"> <li>3. Water Outlet: You can choose whether to produce an alarm when the outlet water temperature sensor is abnormal (the outlet water temperature sensor is an optional accessory).</li> <li>4. Remote Sensor: Delta CoolDoor can detect the temperature and humidity of the channel environment, and you can choose whether to produce an alarm when the temperature and humidity sensors are abnormal (the remote temperature sensor is an optional accessory).</li> <li>5. Condensation: Select <input checked="" type="checkbox"/>; when the environmental dew point is too high and there is a risk of condensation, an alarm will be generated. This function must be used with the Remote Sensor option.</li> <li>6. Fire Detection: Select <input checked="" type="checkbox"/>; an alarm will be generated when the fire and smoke dry contact status transitions.</li> </ol> |
| Leak SEN. : High                                    |  |  |  |   |   |  |   |   |
| Water Inlet T: <input checked="" type="checkbox"/>  |  |  |  |   |   |  |   |   |
| Water Outlet T: <input checked="" type="checkbox"/> |  |  |  |   |   |  |   |   |
| Remote Sensor : <input checked="" type="checkbox"/> |  |  |  |   |   |  |   |   |
| Condensation : <input checked="" type="checkbox"/>  |  |  |  |   |   |  |   |   |
| Fire Detection: <input checked="" type="checkbox"/> |  |  |  |   |   |  |   |   |
| <p><b>Actuator Alarm</b></p>                        | <table border="1"> <tr> <td>Ball Valve : <input checked="" type="checkbox"/></td> </tr> <tr> <td>Fan 1 : <input checked="" type="checkbox"/></td> </tr> <tr> <td>Fan 2 : <input checked="" type="checkbox"/></td> </tr> <tr> <td>Fan 3 : <input checked="" type="checkbox"/></td> </tr> <tr> <td>Fan 4 : <input checked="" type="checkbox"/></td> </tr> <tr> <td>Fan 5 : <input type="checkbox"/></td> </tr> </table>                  | Ball Valve : <input checked="" type="checkbox"/> | Fan 1 : <input checked="" type="checkbox"/>        | Fan 2 : <input checked="" type="checkbox"/>         | Fan 3 : <input checked="" type="checkbox"/>         | Fan 4 : <input checked="" type="checkbox"/>        | Fan 5 : <input type="checkbox"/>                    | <p><b>Main menu</b> → <b>Setting</b> → <b>Set Alarm</b><br/> → <b>Actuator Alarm</b>, press  key to enter.</p> <p>The driver alarm page can be adjusted by the user, as explained below</p> <ol style="list-style-type: none"> <li>1. Ball Valve: Select <input checked="" type="checkbox"/>; an alarm will be generated when the ball valve is abnormal.</li> <li>2. Fan 1~5: Select <input checked="" type="checkbox"/>; an alarm will be generated when the fan is abnormal.</li> </ol>   |
| Ball Valve : <input checked="" type="checkbox"/>    |  |  |  |   |   |  |   |   |
| Fan 1 : <input checked="" type="checkbox"/>         |  |  |  |   |   |  |   |   |
| Fan 2 : <input checked="" type="checkbox"/>         |  |  |  |   |   |  |   |   |
| Fan 3 : <input checked="" type="checkbox"/>         |  |  |  |   |   |  |   |   |
| Fan 4 : <input checked="" type="checkbox"/>         |  |  |  |   |   |  |   |   |
| Fan 5 : <input type="checkbox"/>                    |  |  |  |   |   |  |   |   |

|  |  |  |              |  |             |  |               |  |              |  |             |  |                |  |              |  |             |  |              |   |
|--|--|--|--------------|--|-------------|--|---------------|--|--------------|--|-------------|--|----------------|--|--------------|--|-------------|--|--------------|---|
| <b>Out of Range</b>                              | <table border="1" style="width: 100%; border-collapse: collapse;"> <tr> <td style="padding: 2px;"><input checked="" type="checkbox"/> Supply Air</td> <td style="padding: 2px;">T High : 86F</td> </tr> <tr> <td style="padding: 2px;"><input checked="" type="checkbox"/> Supply Air</td> <td style="padding: 2px;">T Low : 57F</td> </tr> <tr> <td style="padding: 2px;"><input checked="" type="checkbox"/> Return Air</td> <td style="padding: 2px;">T High : 131F</td> </tr> <tr> <td style="padding: 2px;"><input checked="" type="checkbox"/> Remote Air T</td> <td style="padding: 2px;">T High : 86F</td> </tr> <tr> <td style="padding: 2px;"><input checked="" type="checkbox"/> Remote Air</td> <td style="padding: 2px;">T Low : 57F</td> </tr> <tr> <td style="padding: 2px;"><input checked="" type="checkbox"/> Remote Air</td> <td style="padding: 2px;">DP T High: 53F</td> </tr> <tr> <td style="padding: 2px;"><input checked="" type="checkbox"/> Water In</td> <td style="padding: 2px;">T High : 68F</td> </tr> <tr> <td style="padding: 2px;"><input checked="" type="checkbox"/> Water In</td> <td style="padding: 2px;">T Low : 46F</td> </tr> <tr> <td style="padding: 2px;"><input type="checkbox"/> Water Flow Rate</td> <td style="padding: 2px;">Low : 0.5GPM</td> </tr> </table> | <input checked="" type="checkbox"/> Supply Air | T High : 86F | <input checked="" type="checkbox"/> Supply Air | T Low : 57F | <input checked="" type="checkbox"/> Return Air | T High : 131F | <input checked="" type="checkbox"/> Remote Air T | T High : 86F | <input checked="" type="checkbox"/> Remote Air | T Low : 57F | <input checked="" type="checkbox"/> Remote Air | DP T High: 53F | <input checked="" type="checkbox"/> Water In | T High : 68F | <input checked="" type="checkbox"/> Water In | T Low : 46F | <input type="checkbox"/> Water Flow Rate | Low : 0.5GPM | <p><b>Main menu</b> → <b>Setting</b> → <b>Set Alarm</b><br/>→ <b>Out of Range</b>, press  key to enter.</p> <p>The out-of-range alarm page can be adjusted by the user, as explained below</p> <ol style="list-style-type: none"> <li>1. <b>Supply Air T High:</b> It can be turned on by <input checked="" type="checkbox"/>; an appropriate temperature value can be set according to customer needs. When the outlet air temperature is higher than the configured value, an alarm will be generated.</li> <li>2. <b>Supply Air T Low:</b> It can be turned on by <input checked="" type="checkbox"/>; an appropriate temperature value can be set according to customer needs. When the outlet air temperature is lower than the configured value, an alarm will be generated.</li> <li>3. <b>Return Air T High:</b> It can be turned on by <input checked="" type="checkbox"/>; an appropriate temperature value can be set according to customer needs. When the outlet air temperature is higher than the configured value, an alarm will be generated.</li> <li>4. <b>Remote Air T High:</b> It can be turned on by <input checked="" type="checkbox"/>; an appropriate temperature value can be set according to customer needs. When the dry ball temperature on the remote sensor is lower than the configured value, an alarm will be generated.</li> <li>5. <b>Remote Air T Low:</b> It can be turned on by <input checked="" type="checkbox"/>; an appropriate temperature value can be set according to customer needs. When the dry ball temperature on the remote sensor is lower than the configured value, an alarm will be generated.</li> <li>6. <b>Remote Air DP T High:</b> It can be turned on by <input checked="" type="checkbox"/>; an appropriate temperature value can be set according to customer needs. When the wet ball temperature on the remote sensor is higher than the configured value, an alarm will be generated.</li> </ol> |
|  | <input checked="" type="checkbox"/> Supply Air   | T High : 86F                                   |              |  |             |  |               |  |              |  |             |  |                |  |              |  |             |  |              |   |
| <input checked="" type="checkbox"/> Supply Air   | T Low : 57F  |  |              |  |             |  |               |  |              |  |             |  |                |  |              |  |             |  |              |   |
| <input checked="" type="checkbox"/> Return Air   | T High : 131F  |  |              |  |             |  |               |  |              |  |             |  |                |  |              |  |             |  |              |   |
| <input checked="" type="checkbox"/> Remote Air T | T High : 86F   |  |              |  |             |  |               |  |              |  |             |  |                |  |              |  |             |  |              |   |
| <input checked="" type="checkbox"/> Remote Air   | T Low : 57F  |  |              |  |             |  |               |  |              |  |             |  |                |  |              |  |             |  |              |   |
| <input checked="" type="checkbox"/> Remote Air   | DP T High: 53F   |  |              |  |             |  |               |  |              |  |             |  |                |  |              |  |             |  |              |   |
| <input checked="" type="checkbox"/> Water In     | T High : 68F   |  |              |  |             |  |               |  |              |  |             |  |                |  |              |  |             |  |              |   |
| <input checked="" type="checkbox"/> Water In     | T Low : 46F  |  |              |  |             |  |               |  |              |  |             |  |                |  |              |  |             |  |              |   |
| <input type="checkbox"/> Water Flow Rate         | Low : 0.5GPM   |  |              |  |             |  |               |  |              |  |             |  |                |  |              |  |             |  |              |   |

|  |  |  |
|--|--|--|
| <b>Out of Range</b>                            | <input checked="" type="checkbox"/> Supply Air   | <p>7. Water In T High: It can be turned on by <input checked="" type="checkbox"/>; an appropriate temperature value can be set according to customer needs. When the water inlet temperature is higher than the configured value, an alarm will be generated.</p> <p>8. Water In T Low: It can be turned on by <input checked="" type="checkbox"/>; an appropriate temperature value can be set according to customer needs. When the water inlet temperature is lower than the configured value, an alarm will be generated.</p> <p>9. Water Flow Rate Low: It can be turned on by <input checked="" type="checkbox"/>; an appropriate temperature value can be set according to customer needs. When the water inflow is lower than the configured value, an alarm will be generated.</p> <p>10. Water Flow Rate Low: It can be turned on by <input checked="" type="checkbox"/>; an appropriate temperature value can be set according to customer needs. When the water inflow is lower than the configured value, an alarm will be generated.</p> |
|  | T High : 86F                                     |  |
|  | <input checked="" type="checkbox"/> Supply Air   |  |
|  | T Low : 57F                                      |  |
|  | <input checked="" type="checkbox"/> Return Air   |  |
|  | T High : 131F                                    |  |
|  | <input checked="" type="checkbox"/> Remote Air T |  |
|  | T High : 86F                                     |  |
|  | <input checked="" type="checkbox"/> Remote Air   |  |
|  | T Low : 57F                                      |  |
| <input checked="" type="checkbox"/> Remote Air |  |  |
| DP T High: 53F                                 |  |  |
| <input checked="" type="checkbox"/> Water In   |  |  |
| T High : 68F                                   |  |  |
| <input checked="" type="checkbox"/> Water In   |  |  |
| T Low : 46F                                    |  |  |
| <input type="checkbox"/> Water Flow Rate       |  |  |
| Low : 0.5GPM                                   |  |  |

## 6.4 Account Access Authorization & Log-in

When the user is operating on a specific page, the user needs to enter permissions before it can be used.

The three operation permissions are as follows:

| Operator Status      | Permission   |
|----------------------|--|
| User                 | System on/off control, System status, Run hours and Event log.                         |
| Device Manager       | System on/off control, System status, Run hours, Event log and Setting.                |
| System Administrator | System on/off control, System status, Run hours, Event log, Setting and Administrator. |

Log-in password from Device Manager is set as default: 0000.



### NOTE:

In order to avoid unauthorized alteration of or access to important settings, do not disclose the administrator password freely. To obtain an administrator password, please contact the service staff of the Company.

## 6.5 Turbo Boost

Delta CoolDoor provides auxiliary solutions when equipment abnormalities occur, called Turbo Boost. Turbo boost is a fail-safe design. When the machine fails to work normally, the adjacent CoolDoor will monitor and assist in the operation to reduce the heat load.

Turbo Boost provides leakage, ball valve, fan and condensation protection.

### Step 1

After installing the CoolDoor duct on the rack (see *Chapter 3.4.2*), use a Phillips screwdriver to remove the covers on both sides as shown in *Figure 6-1*. Please note that there is no need to remove the outermost covers of the first and last ducts (see *Figure 6-2*).

Remove the covers  
on both sides  
(total: 10 pieces)

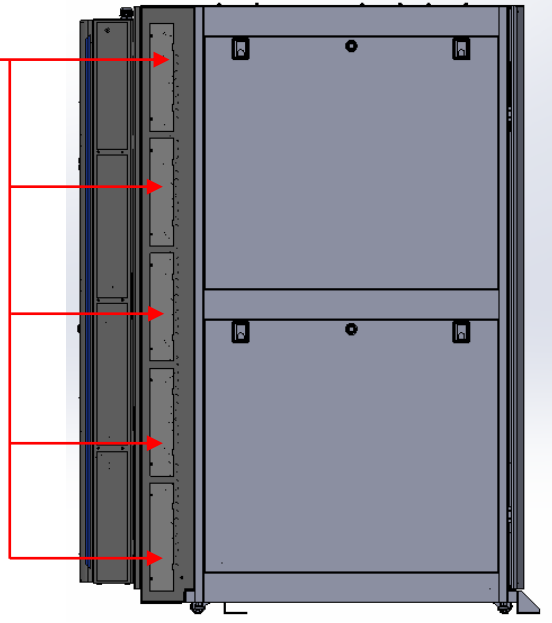
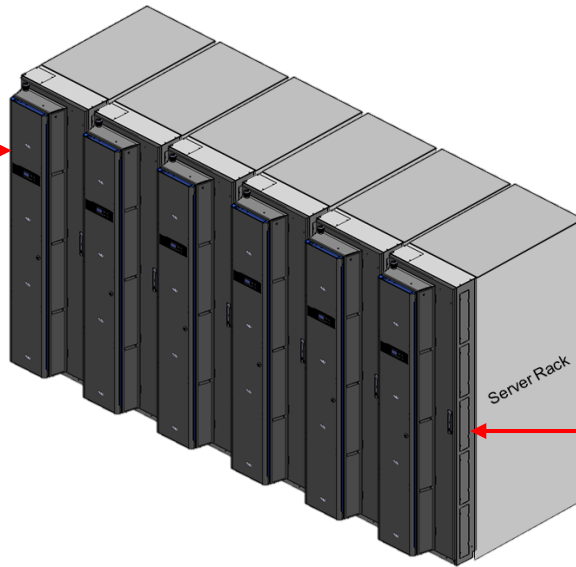

Figure 6-1: CoolDoor Duct Side Covers

The outermost  
covers of the  
first duct



The outermost  
covers of the  
last duct

Figure 6-2: The Outmost Covers of the First and Last Ducts

**Step 2**

After completing the procedures stated in *chapter 3.4.3*, ensure that the CoolDoor is positioned well.

**Step 3**

Use the control panel to select 'Turbo boost'. As the adjacent CoolDoors are connected via CAN-Link (see *Figure 4-10*), you can use the CAN-Link to set up each CoolDoor.

**Step 4**

Set up each CoolDoor ID. The IDs must be consecutive (for example 1, 2, 3 and so on) for the adjacent CoolDoors.

**Step 5**

Turn on the Turbo boost.

## Chapter 7 : Optional Accessories

If you need to purchase the following accessories, please contact service personnel.

- **SNMP card:** It can provide the best compatibility.
- **Remote temperature and humidity sensor:** It can monitor the environmental dew point temperature and reduce the risk of condensation through the CoolDoor control.
- **Quick joint:** Easy and fast hose pipe replacement.
- **Pressure independent control valve:** The water volume can be balanced without going through a balancing valve.
- **Cut off valve:** It can block the waterway when the system leaks.
- **Flow meter:** It can monitor the flow of the CoolDoor and be used for TAB adjustment.

## Chapter 8 : Fault Code & Description

### 8.1 Troubleshooting



**WARNING:**

The following troubleshooting program may only be run by qualified service staff. Unauthorized operation can lead to major hazards or equipment damage.

| Phenomenon                | Possible cause  | Troubleshooting Instructions  |
|---------------------------|---|---|
| <b>Unable to start up</b> | The circuit breaker of the external electric panel is not powered on. | Power the circuit breaker.<br>Check if the power communication cable of the TP is normal.<br>Check if the single screen can be operated normally through the touch panel. |
|                           | The fuse installed in the CoolDoor's fuse holder is failed.           |   |
|                           | The power cable of the touch panel is experiencing abnormality.       |   |
|                           | The touch panel has failed.   |   |
| <b>No air flow</b>        | The fan switch in the electric panel is not turned on.                | Check that the fan switch in the electric panel is turned on.   |
|                           | Fan fuse blown.   |   |
|                           | The fan communication & power terminal is not connected               | Check that the power supply and communication terminals are properly connected.   |
|                           | The fan fuse is blown.  | Check the fan fuse.   |
| <b>Not enough cooling</b> | The fan is failed   | Replace the fan.  |
|                           | The chiller is not supplying chilled water as usual.                  | Check the chiller.  |
|                           | The ball valve and cut-off valve have failed.                         | Check if the line is properly connected.  |
|                           | Blocked or dirty coil fins.   | Check whether the coil fins are too dirty or blocked by foreign objects.  |

| Phenomenon                             | Possible cause   | Troubleshooting Instructions   |
|--|--|--|
| <b>Not enough cooling</b>              | PID parameters are set up inappropriately.   | Check whether it is the default value.   |
|  | Damaged coil fins.   | Please contact the service staff.  |
|  | Fire or remote dry contact trigger.  | Check whether the dry contact remains "Normal Open".   |
|  | Check whether the water leakage shutdown is turned on and the leakage alarm is triggered | Resolve the leak state.<br>Turn off leakage BV off function.                                   |
|  | Main pipe or branch pipe chilled water valve closed                                      | Turn on the chilled water valve.   |
|  | Unbalanced water flow in water system.   | It is recommended that you install a balance valve and perform TAB adjustment.                 |
| <b>Abnormal noise during operation</b> | There are foreign matters attached to the fan or the ball bearing is damaged.            | Check the fan and replace it if necessary.   |
|  | There are foreign matters or impurities in the pipeline.                                 | Check the external piping filter and clean it if necessary.                                    |
| <b>Water stain inside the unit</b>     | The humidity is too high.  | Confirm whether the environment is within the working range stated in <b>Chapter 5.2</b> .     |
|  | The incoming water temperature is too low.   | Adjust the alarm configured value or check the water temperature at the outlet of the chiller. |
|  | The rotation speed of the fan is too low.  | Adjust the minimum rotation speed of the fan.  |

| Phenomenon   | Possible cause                 | Troubleshooting Instructions  |
|--|--------------------------------|---|
| Water leakage at the bottom of the unit            | The condensate is overflowing. | Confirm whether the environment is within the working range stated in <b>Chapter 5.2</b> .                      |
|  | External piping water leakage. | Check the leakage site and repair it.   |
|  | Coil damage and leakage.       | Confirm whether the installation is damaged by collision.<br>Confirm that the supply water pressure is correct. |
|  | Leakage line sensor failure.   | Replace the leakage line sensor.  |
| Abnormal Touch Panel display or absence of display | The connections are wrong.     | Check if the connections to the console are correct; restart the distribution board if necessary.               |
|  | Screen failure                 | Replace with a new screen.  |

## 8.2 Warning Codes

| Event ID | Alarm Name        | Alert Level * | System Action after Alarm   | Possible Cause   | Method of Exclusion   |
|----------|-------------------|---------------|---|--|---|
| 28       | Water Leak Active | 2             | 1. Alarm display<br>2. When the stop function is on for leakage, the ball valve is closed | 1. Generation of condensate<br>2. Water leakage in pipe joints | 1. Check the environmental humidity<br>2. Check coil and pipeline for leaks |
| 150      | Leak Line Open    | 2             | 1. Alarm display  | 1. Leak detection line is off or not connected properly        | 1. Check the wiring of the leakage sensing line                             |

| Event ID | Alarm Name                      | Alert Level * | System Action after Alarm   | Possible Cause  | Method of Exclusion  |
|----------|---------------------------------|---------------|---|---|--|
| 30       | Fire/ Smoke                     | 2             | <ol style="list-style-type: none"> <li>1. Alarm display</li> <li>2. Turn on the fire emergency stop to cause the entire device to stop running</li> </ol> | <ol style="list-style-type: none"> <li>1. Fire and smoke input contact trigger</li> </ol>   | <ol style="list-style-type: none"> <li>1. Check the surrounding environment and eliminate abnormalities</li> <li>2. External sensor abnormality</li> </ol>   |
| 32       | Input Feed A Abnormal           | 1             | <ol style="list-style-type: none"> <li>1. Alarm display; switch the power to Feed B</li> </ol>  | <ol style="list-style-type: none"> <li>1. Input Feed A power supply is not within the scope of application</li> </ol>                                 | <ol style="list-style-type: none"> <li>1. Check the power supply</li> </ol>  |
| 34       | Group Communication Abnormality | 1             | Alarm display   | <ol style="list-style-type: none"> <li>1. Wiring error</li> <li>2. Duplicate unit ID setting</li> <li>3. Terminal resistance setting error</li> </ol> | <ol style="list-style-type: none"> <li>1. Check communication wiring between groups</li> <li>2. Check ID settings of each device in the group</li> <li>3. Check the terminal resistance setting</li> </ol> |
| 38       | Control Valve Abnormal          | 2             | Alarm display   | <ol style="list-style-type: none"> <li>1. The ball valve circuit is loose or in poor contact</li> <li>2. Ball valve cannot move</li> </ol>            | <ol style="list-style-type: none"> <li>1. Check whether the ball valve circuit is properly connected</li> <li>2. Check whether foreign objects are stuck in the ball valve</li> </ol>                      |
| 42       | Supply Air Sensor 1 Abnormal    | 2             | <ol style="list-style-type: none"> <li>1. Alarm display</li> <li>2. Ball valve fully open</li> </ol>  | <ol style="list-style-type: none"> <li>1. Wiring is loose</li> <li>2. Sensor unit abnormality</li> </ol>  | <ol style="list-style-type: none"> <li>1. Check sensor wiring</li> <li>2. Check sensor unit and replace if necessary</li> </ol>  |

| Event ID | Alarm Name                   | Alert Level * | System Action after Alarm   | Possible Cause   | Method of Exclusion  |
|----------|------------------------------|---------------|---|--|--|
| 40       | Return Air Sensor 1 Abnormal | 2             | 1. Alarm display<br>2. 1 Failure is controlled by normal return air sensor<br>3. 2 One failure; running at 70% minimum fan speed<br>4. 3 One failure; the fan speed is 100% | 1. Wiring is loose<br>2. Sensor unit abnormality   | 1. Check sensor wiring<br>2. Check sensor unit and replace if necessary  |
| 40       | Return Air Sensor 2 Abnormal | 2             |   |  |  |
| 40       | Return Air Sensor 3 Abnormal | 2             |   |  |  |
| 64       | Fan CH1 Abnormal             | 2             | 1. Alarm display<br>2. One fan fails; the minimum speed is 70%<br>3. More than two fans fail; the minimum speed is 100%   | 1. Fan terminal is loose<br>2. The blade is stuck due to foreign matter<br>3. Fan unit abnormality | 1. Check the fan wiring<br>2. Remove foreign objects and confirm that the blades are not damaged<br>3. Replace the fan |
| 66       | Fan CH2 Abnormal             | 2             |   |  |  |
| 68       | Fan CH3 Abnormal             | 2             |   |  |  |
| 70       | Fan CH4 Abnormal             | 2             |   |  |  |
| 56       | Inlet Water Sensor Abnormal  | 2             | 1. Alarm display  | 1. Wiring is loose<br>2. Sensor unit abnormality   | 1. Check sensor wiring<br>2. Check sensor unit and replace if necessary  |
| 58       | Outlet Water Sensor Abnormal | 2             | 1. Alarm display  | 1. Wiring is loose<br>2. Sensor unit abnormality   | 1. Check sensor wiring<br>2. Check sensor unit and replace if necessary  |

| Event ID | Alarm Name                 | Alert Level * | System Action after Alarm   | Possible Cause   | Method of Exclusion  |
|----------|----------------------------|---------------|---|--|--|
| 44       | Remote Air Sensor Abnormal | 2             | 1. Alarm display  | <ol style="list-style-type: none"> <li>1. Wiring is loose</li> <li>2. Sensor unit abnormality</li> <li>3. DIP switch ID setting error</li> </ol>   | <ol style="list-style-type: none"> <li>1. Check sensor wiring</li> <li>2. Check sensor unit and replace if necessary</li> <li>3. Confirm that the DIP switch is 0000</li> </ol>                |
| N        | Press Sensor Abnormal      | 2             | <ol style="list-style-type: none"> <li>1. Alarm display</li> <li>2. Switch back to air sensor control</li> </ol>              | <ol style="list-style-type: none"> <li>1. Wiring is loose</li> <li>2. Sensor unit abnormality</li> </ol>   | <ol style="list-style-type: none"> <li>1. Check sensor wiring</li> <li>2. Check sensor unit and replace if necessary</li> </ol>  |
| 60       | Flow Meter Abnormal        | 2             | 1. Alarm display  | <ol style="list-style-type: none"> <li>1. Wiring is loose</li> <li>2. Sensor unit abnormality</li> </ol>   | <ol style="list-style-type: none"> <li>1. Check the flow meter wiring</li> <li>2. Check the flow meter unit and replace if necessary</li> </ol>  |
| 252      | High Condensation Risk     | 2             | <ol style="list-style-type: none"> <li>1. Alarm display</li> <li>2. The minimum supply air temperature is set 26°C</li> </ol> | <ol style="list-style-type: none"> <li>1. Room humidity is too high</li> <li>2. Chilled water temperature is too low</li> </ol>                    | <ol style="list-style-type: none"> <li>1. Check whether the room dehumidifier is working properly</li> <li>2. Check whether the temperature of the chilled water circuit is too low</li> </ol> |
| 92       | Return Air T High          | 1             | Alarm display   | <ol style="list-style-type: none"> <li>1. Heat load exceeds cooling capacity</li> <li>2. The configured value of the alarm is incorrect</li> </ol> | <ol style="list-style-type: none"> <li>1. Reduce heat load or increase cooling device</li> <li>2. Check the configured value of the alarm</li> </ol>   |

| Event ID | Alarm Name        | Alert Level * | System Action after Alarm | Possible Cause  | Method of Exclusion  |
|----------|-------------------|---------------|---------------------------|---|--|
| 100      | Supply Air T High | 1             | Alarm display             | <ol style="list-style-type: none"> <li>1. Heat load exceeds cooling capacity</li> <li>2. The configured value of the alarm is incorrect</li> </ol>  | <ol style="list-style-type: none"> <li>1. Reduce heat load or increase cooling device</li> <li>2. Check the configured value of the alarm</li> </ol>   |
| 102      | Supply Air T Low  | 1             | Alarm display             | <ol style="list-style-type: none"> <li>1. The inlet chilled water temperature is too low</li> <li>2. Environmental heat load is too low</li> <li>3. The configured value of the alarm is incorrect</li> </ol> | <ol style="list-style-type: none"> <li>1. Check if the chilled water temperature is abnormal</li> <li>2. Check the configured value of the alarm</li> </ol>  |
| 104      | Remote T High     | 1             | Alarm display             | <ol style="list-style-type: none"> <li>1. The channel heat load exceeds the cooling capacity</li> <li>2. The air setting is abnormal</li> <li>3. The configured value of the alarm is incorrect</li> </ol>    | <ol style="list-style-type: none"> <li>1. Poor load matching</li> <li>2. Confirm whether the temperature setting for each outlet is correct</li> <li>3. Check the configured value of the alarm</li> </ol> |
| 106      | Remote T Low      | 1             | Alarm display             | <ol style="list-style-type: none"> <li>1. The air setting is abnormal</li> <li>2. The configured value of the alarm is incorrect</li> </ol>   | <ol style="list-style-type: none"> <li>1. Confirm whether the temperature setting for each outlet is correct</li> <li>2. Check the configured value of the alarm</li> </ol>                                |

| Event ID | Alarm Name            | Alert Level * | System Action after Alarm | Possible Cause  | Method of Exclusion   |
|----------|-----------------------|---------------|---------------------------|---|---|
| 114      | Remote DP T High      | 1             | Alarm display             | <ol style="list-style-type: none"> <li>1. Environmental humidity is too high</li> <li>2. The configured value of the alarm is incorrect</li> </ol>  | <ol style="list-style-type: none"> <li>1. Check the environmental humidity or add a dehumidifier</li> <li>2. Check the configured value of the alarm</li> </ol>   |
| 148      | Over Maintenance Time | 1             | Alarm display             | <ol style="list-style-type: none"> <li>1. Over maintenance time</li> </ol>  | <ol style="list-style-type: none"> <li>1. Perform maintenance</li> </ol>  |
| 166      | Water Inlet T High    | 1             | Alarm display             | <ol style="list-style-type: none"> <li>1. Abnormal temperature of chilled water supply</li> <li>2. Chilled water supply flow is too low</li> <li>3. The configured value of the alarm is incorrect</li> </ol> | <ol style="list-style-type: none"> <li>1. Check whether the temperature of the chilled water circuit is too high</li> <li>2. Check whether the working condition of the chilled water circuit pump is normal</li> <li>3. Check the configured value of the alarm</li> </ol> |
| 168      | Water Inlet T Low     | 1             | Alarm display             | <ol style="list-style-type: none"> <li>1. Abnormal temperature of chilled water supply</li> <li>2. The configured value of the alarm is incorrect</li> </ol>  | <ol style="list-style-type: none"> <li>1. Check whether the temperature of the chilled water circuit is too low</li> <li>2. Check the configured value of the alarm</li> </ol>  |

| Event ID | Alarm Name          | Alert Level * | System Action after Alarm | Possible Cause  | Method of Exclusion   |
|----------|---------------------|---------------|---------------------------|---|---|
| N        | Water Outlet T High | 1             | Alarm display             | <ol style="list-style-type: none"> <li>1. Abnormal temperature of chilled water supply</li> <li>2. Chilled water supply flow is too low</li> <li>3. The configured value of the alarm is incorrect</li> </ol> | <ol style="list-style-type: none"> <li>1. Check whether the temperature of the chilled water circuit is too high</li> <li>2. Check whether the working condition of the chilled water circuit pump is normal</li> <li>3. Check the configured value of the alarm</li> </ol> |

\*: 1 means Warning; 2 means Severe

## Chapter 9 : Maintenance & Cleaning

Periodically inspecting and cleaning this air handling device helps ensure optimal operational status of the equipment.

Internal elements such as the fan and the coil need to be cleaned and inspected periodically. This device contains replaceable elements that only qualified service staff may clean and inspect.

### 9.1 Component Maintenance

#### 1. Coil and door maintenance

The CoolDoor does not have a filter to filter the air. The system will first cool the air through the coil and then send it out through the fan. Therefore, the coil can easily become blocked by dust from the air in the IT room. It is recommended that you maintain and clean it every season. If air quality is poor, it is recommended that you increase cleaning frequency.

- A. Check that the key can properly lock and unlock the door, and confirm whether the door latch can open and close normally.
- B. Check whether the door opens smoothly; confirm whether the soft tube causes undue drag or friction.
- C. Check whether there are water marks on the surface of the pipe, and confirm whether there is leakage at the connection between the soft tube and the coil.
- D. Use a soft brush or an air blower to clean the air inlet of the coil. Do not apply excessive force, which may cause the coil fins to bend or the surface of the fins to become damaged.
- E. Open the exhaust valve, and appropriately use the soft tube connection to confirm whether there is air accumulation on the inside. Ensure that the coil is effective. After finished, confirm whether the upper and lower exhaust valve caps are on tight.

#### 2. Fan and panel door maintenance

- A. Before turning off the power, first confirm whether the lower LED light bar displays correctly; Power Feed A is blue and Power Feed B is green. You can activate the abnormality alarm of the air sensor by unplugging the quick connection of the air sensor during standby; confirm that the light is red, and then restore it.
- B. Check that the key can properly lock and unlock the door, and confirm whether the door latch can open and close normally. Then confirm whether the panel door opens smoothly.
- C. Confirm that running fans are running at normal speeds; you can use the air speed meter to measure the air volume of each fan.
- D. Confirm whether the total operating current is within the maximum value on the nameplate.

### 3. Operation and Maintenance

- A. Read and record all current set points, alarm set points, valve and fan output signals. Read and record any current alarm history, and confirm the causes and solutions. Refer to troubleshooting. If necessary, consult Delta professional customer service.
- B. Check whether the ball valve, electric shut-off valve (optional), flow meter (optional), and water leakage sensing line are correctly connected and not loose.
- C. Check whether the measuring soft tube of the differential pressure sensor (optional) is loose.

## 9.2 Component Replacement

Before performing power-off maintenance, the main door of the CoolDoor should be opened. The server can use its own fan to dissipate heat to avoid poor heat dissipation for the server. When troubleshooting or replacing components, ensure that the CoolDoor power is correctly turned off.

### 1. Fuse replacement:

Please investigate the cause of the blown fuse and eliminate the cause before replacing it. Confirm the fuse holder according to section 4.3 and open it; remove the blown fuse, replace it with a spare fuse of the same rated current, and push the fuse holder back in after replacement. Use an electric meter to measure the resistance value to confirm the fuse holder and to confirm whether it is conducting.

### 2. Fan replacement:



#### **WARNING:**

Be sure to disconnect the power supply and confirm that the fan stops before proceeding.

First confirm which fan needs to be replaced. After unplugging the power cable and signal cable, remove the connecting terminal from its holder, as shown in Figure 1 below. Then remove the screws at the four corners with a screwdriver, as shown in Figure 2, and take out the fan. Finally, remove the four screws around the fan motor at position 3 below with a screwdriver to separate the fixed plate from the fan. Install the new fan back onto the CoolDoor in the reverse order to complete the fan replacement.

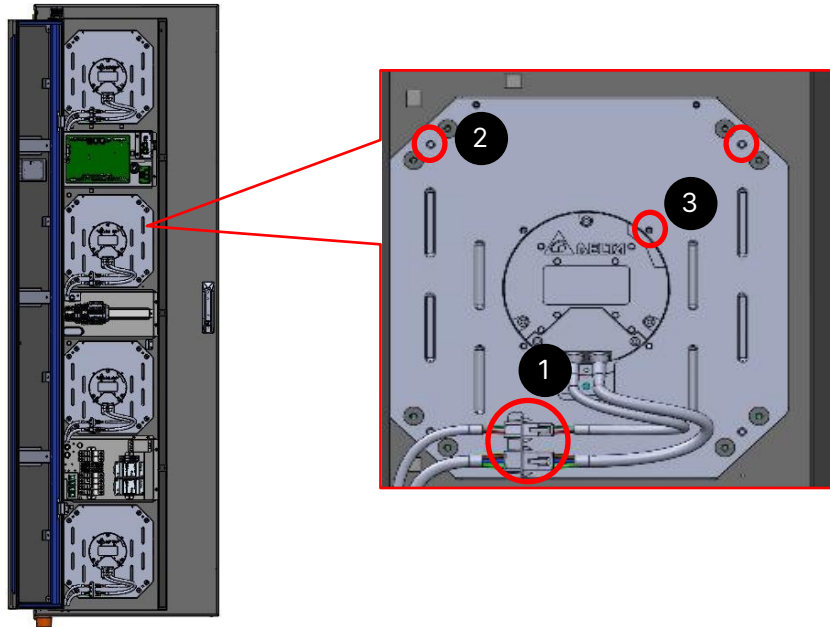

## 9.3 Quarterly Maintenance

Date:

Model number:

Performed by:

|  |                                   |
|--|-----------------------------------|
| <b>((!)) It is important that you disconnect and lock up input power prior to cleaning the following elements.</b> |                                   |
| <b>Open the main coil door and confirm the following:</b>  |                                   |
| Clean the coil inlet fins with an air gun  | <input type="checkbox"/> Finished |
| Manually press the air vent to confirm that there is no air accumulation   | <input type="checkbox"/> Finished |
| Check if the fin are damaged   | <input type="checkbox"/> Finished |
| Whether the return air sensor is loose or obviously damaged  | <input type="checkbox"/> Finished |
| Check whether there is water leakage at the water pipe connection  | <input type="checkbox"/> Finished |
| Check whether the leak detection line is loose   | <input type="checkbox"/> Finished |
| Check whether the hose of the pressure difference sensor is off or squeezed (optional)                             | <input type="checkbox"/> Finished |
| <b>Open the front electric panel door and confirm the following:</b>   |                                   |
| Confirm whether the main power wiring is loose   | <input type="checkbox"/> Finished |
| Confirm whether the grounding is loose   | <input type="checkbox"/> Finished |
| <b>External inspection:</b>  |                                   |
| Clean the air outlet grille with an air gun  | <input type="checkbox"/> Finished |
| Check whether the ball valve(or PICV) connection line is off   | <input type="checkbox"/> Finished |
| Check whether the cut off valve connection line is off (optional)  | <input type="checkbox"/> Finished |
| Check whether the flow meter connection line is off (optional)   | <input type="checkbox"/> Finished |
| Check whether the dew point temperature sensor cable is off (optional)   | <input type="checkbox"/> Finished |
| <b>General Check</b>   |                                   |
| Whether the sampled water quality meets the specifications   | <input type="checkbox"/> Finished |

|  |                                   |
|--|-----------------------------------|
| <b>((!)) The following tests will be carried out with a power supply and should be tested by professionally trained personnel.</b> |                                   |
| <b>Open the front electric panel door and confirm the following:</b>   |                                   |
| When there is no alarm, input the power of Feed A, and whether the LED light bar is blue   | <input type="checkbox"/> Finished |
| When there is no alarm, input the power of Feed B, and whether the LED light bar is green  | <input type="checkbox"/> Finished |
| Turning off a fan with a switch will cause an alarm, and whether the LED light bar is red  | <input type="checkbox"/> Finished |
| <b>General Check</b>   |                                   |
| Is the water supply from the chiller normal?   | <input type="checkbox"/> Finished |
| Check if the Y filter is blocked   | <input type="checkbox"/> Finished |
| Check if the Inlet water temperature is normal   | <input type="checkbox"/> Finished |
| Check if the Inlet water pressure is normal  | <input type="checkbox"/> Finished |
| <b>Notes:</b>  |                                   |
|  |                                   |
| Signature: _____   |                                   |

**Please make copies of this page to facilitate use during maintenance and inspection.**

## Chapter 10 : MODBUS Table

This system supports MODBUS protocol transmission.

Communication format: RTU

Baud rate: 9600.

Data bit: 8 bits.

Parity: None.

Stop bit: 1 bit.

COMMAND SUPPORT:

|                          |       |
|--------------------------|-------|
| Read Input Data Register | 0x04h |
|--------------------------|-------|

| Address | Description                 | R/W | Length  | Unit   | Note       |               |
|---------|-----------------------------|-----|---------|--------|------------|---------------|
|         |                             |     |         |        |            |               |
| 0x104   | Remote T                    | R   | 2 Bytes | 0.1°C  |            |               |
| 0x105   | Remote RH                   | R   | 2 Bytes | 0.1%   |            |               |
| 0x116   | Chilled Water Inlet T       | R   | 2 Bytes | 0.1°C  |            |               |
| 0x117   | Chilled Water Outlet T      | R   | 2 Bytes | 0.1°C  |            |               |
| 0x118   | Chilled Water Flow Rate     | R   | 2 Bytes | 0.1LPM |            |               |
| 0x119   | Ball valve opening feedback | R   | 2 Bytes | 0.1%   | 0.0-100.0% |               |
| 0x121   | DI Status Flag 1            | R   | 2 Bytes | Null   | b0:        | Rev           |
|         |                             |     |         |        | b1:        | Fan 1 failure |
|         |                             |     |         |        | b2:        | Fan 2 failure |
|         |                             |     |         |        | b3:        | Fan 3 failure |
|         |                             |     |         |        | b4:        | Fan 4 failure |

| Address | Description      | R/W | Length  | Unit  | Note  |   |     |
|---------|------------------|-----|---------|-------|-------|---|-----|
| Hex     |                  |     |         |       |       |   |     |
| 0x121   | DI Status Flag 1 | R   | 2 Bytes | Null  | b5:   | Rev                                       |     |
|         |                  |     |         |       | b6:   |   |     |
|         |                  |     |         |       | b7:   |   |     |
|         |                  |     |         |       | b8:   |   |     |
|         |                  |     |         |       | b9:   |   |     |
|         |                  |     |         |       | b10:  | EPO                                       |     |
|         |                  |     |         |       | b11:  |   |     |
|         |                  |     |         |       | b12:  |   | Rev |
|         |                  |     |         |       | b13:  |   |     |
|         |                  |     |         |       | b14:  |   |     |
|         |                  |     |         |       | b15:  |   |     |
|         |                  |     |         |       |       |   |     |
| 0x14B   | Return air T 1   | R   | 2 Bytes | 0.1°C |       |   |     |
| 0x14C   | Return air T 2   | R   | 2 Bytes | 0.1°C |       |   |     |
| 0x14D   | Return air T 3   | R   | 2 Bytes | 0.1°C |       |   |     |
| 0x14E   | Supply air T 1   | R   | 2 Bytes | 0.1°C |       |   |     |
| 0x14F   | Static pressure  | R   | 2 Bytes | Pa    |       |   |     |
| 0x151   | Dry contact      | R   | 2 Bytes | Null  | b0:   | Remote status.<br>0:Standby,<br>1:On      |     |
|         |                  |     |         |       | b1:   | Fire alarm.<br>0:None,<br>1:Fire detected |     |
|         |                  |     |         |       | other | Rev                                       |     |

## Appendix 1 : Technical Specifications

| Model No.                   | Unit          | RWC030D0AK00B8   | RWC050D0AK00B8   |
|-----------------------------|---------------|--|--|
| Power Supply                | φ/Hz/V        | 1φ/50,60Hz/200~240V  | 1φ/50,60Hz/200~240V  |
| Power                       | kW            | 0.54   | 0.75   |
| Cooling Capacity with Water | kW            | 30   | 54   |
| Air Flow                    | CFM           | 3812   | 4016   |
| Water Flow                  | GPM           | 14.5   | 23.8   |
| Unit Pressure Drop          | Feet of Water | 15.1 (45kPa)   | 14.5 (43.2kPa)   |
| COP                         | kW/kW         | 56   | 72   |
| Fan Type                    |               | Electronically commutated (EC) fan   | Electronically commutated (EC) fan   |
| Ball Valve Type             |               | Ball valve- FC   | Ball valve- FC   |
| Size                        | Inches        | 1"   | 1 1/4"   |
| Connection                  | Type          | NPT- female  | NPT- female  |
| Pipe Connection             |               | Top and bottom   | Top and bottom   |
| HMI                         |               | LCD,<br>64×128 pixels, 4 LEDs, 4 buttons                                       | LCD,<br>64×128 pixels, 4 LEDs, 4 buttons                                       |
| LED Light Bar Function      |               | Normal (Blue)<br>Power Feed B (Green)<br>Abnormal Alarm (Red)                  | Normal (Blue)<br>Power Feed B (Green)<br>Abnormal Alarm (Red)                  |
| Ball Valve Control          |               | SA control via PI turning (default)<br>Pressure independent control (optional) | SA control via PI turning (default)<br>Pressure independent control (optional) |
| Water Leakage Detector      |               | Standard, 4m in length   | Standard, 4m in length   |

| Model No.                  | Unit   | RWC030D0AK00B8   | RWC050D0AK00B8   |
|----------------------------|--------|--|--|
| <b>Turbo Boost Control</b> |        | <ol style="list-style-type: none"> <li>1. Fan failure→<br/>Increase the fan speed of neighboring machines.</li> <li>2. Ball valve failure→<br/>Reduce the air outlet temperature setting of the adjacent machines.</li> <li>3. Shared condensation alarm→<br/>Rise the air outlet temperature setting to 26°C to reduce the condensation.</li> </ol> | <ol style="list-style-type: none"> <li>1. Fan failure→<br/>Increase the fan speed of neighboring machines.</li> <li>2. Ball valve failure→<br/>Reduce the air outlet temperature setting of the adjacent machines.</li> <li>3. Shared condensation alarm→<br/>Rise the air outlet temperature setting to 26°C to reduce the condensation.</li> </ol> |
| <b>Height</b>              | Inches | 77.4" (for 42U rack)   | 77.4" (for 42U rack)   |
| <b>Width</b>               | Inches | 23.6" (for 600mm rack)   | 23.6" (for 600mm rack)   |
| <b>Depth</b>               | Inches | 13.6"  | 13.6"  |
| <b>Weight</b>              | lbs    | 198  | 216  |
| <b>Certification</b>       |        | CE   | CE   |
| <b>Optional</b>            |        | <ol style="list-style-type: none"> <li>1. Cut-off Valve (Isolate Leakage RDHx)</li> <li>2. T/RH Sensor-Cold Side Dew Point Monitoring</li> <li>3. PICV Valve</li> <li>4. Air Static Pressure Sensor</li> <li>5. Quick Disconnect Couplings</li> <li>6. BACnet</li> <li>7. SNMP Card</li> </ol>   | <ol style="list-style-type: none"> <li>1. Cut-off Valve (Isolate Leakage RDHx)</li> <li>2. T/RH Sensor-Cold Side Dew Point Monitoring</li> <li>3. PICV Valve</li> <li>4. Air Static Pressure Sensor</li> <li>5. Quick Disconnect Couplings</li> <li>6. BACnet</li> <li>7. SNMP Card</li> </ol>   |

## Appendix 2 : Warranty

Seller warrants this product, if used in accordance with all applicable instructions, to be free from original defects in material and workmanship within the warranty period. If the product has any failure problem within the warranty period, Seller will repair or replace the product at its sole discretion according to the failure situation.

This warranty does not apply to normal wear or to damage resulting from improper installation, operation, usage, maintenance or irresistible force (i.e. war, fire, natural disaster, etc.), and this warranty also expressly excludes all incidental and consequential damages.

Maintenance service for a fee is provided for any damage out of the warranty period. If any maintenance is required, please directly contact the supplier or Seller.

**WARNING:**

The individual user should take care to determine prior to use whether the environment and the load characteristic are suitable, adequate or safe for the installation and the usage of this product. The User Manual must be carefully followed. Seller makes no representation or warranty as to the suitability or fitness of this product for any specific application.

No. : 501329580101

Version : V 1.1

Release Date : 2026\_04\_15

## Global Headquarter

### Taiwan

Delta Electronics Inc.  
30 Section 2, Huandong Road, Shanhua District,  
Tainan City 74144, Taiwan  
T +886 6 505 6565  
E [ups.taiwan@deltaww.com](mailto:ups.taiwan@deltaww.com)

## Regional Office

### Netherlands

Delta Electronics (Netherlands) B.V.  
Zandsteen 15, 2132 MZ Hoofddorp, The Netherlands  
T +31 (0)20 800 3900  
E [info@delta-emea.com](mailto:info@delta-emea.com)

### Poland

Delta Electronics (Poland) Sp. z.o.o.  
23 Poleczki St., 02-822 Warszawa, Poland  
T +48 22 335 2600  
E [ups.poland@deltaww.com](mailto:ups.poland@deltaww.com)

### Brazil

Delta Electronics Brasil Ltda.  
Estrada Velha Rio-São Paulo, 5300 – Eugênio de Melo –  
CEP 12247-001 São José dos Campos-SP-Brazil  
T +55 12 39322300  
E [ups.brazil@deltaww.com](mailto:ups.brazil@deltaww.com)

### Peru

Delta Electronics (Peru) Inc. S.R.L.  
Av. Pardo y Aliaga 699 Of. 601, San Isidro Lima, Peru.  
T +51 962 834 287  
E [ups.peru@deltaww.com](mailto:ups.peru@deltaww.com)

### China

Delta GreenTech (China) Co., Ltd.  
238 Minxia Road, Pudong, Shanghai, 201209 P.R.C  
T +86 21 5863 5678  
+86 21 5863 9595  
E [ups.china@deltaww.com](mailto:ups.china@deltaww.com)

### South Korea

Delta Electronics (Korea), Inc.  
1511, Byucksan Digital Valley 6-cha, Gasan-dong, Geumcheon-gu,  
Seoul, Korea, 153-704  
T +82-2-515-5303  
E [ups.south.korea@deltaww.com](mailto:ups.south.korea@deltaww.com)

### Thailand

Delta Electronics (Thailand) Public Co.,Ltd.  
909 Soi 9, Moo 4, E.P.Z., Bangpoo Industrial Estate, Tambon Phraksa,  
Amphur Muang-samutprakarn, Samutprakarn Province 10280,  
Thailand  
T +662 709-2800  
E [ups.thailand@deltaww.com](mailto:ups.thailand@deltaww.com)

### Philippines

Eltek Power Inc./ Delta  
302 Orient Square Bldg  
F. Ortigas JR Road, Barangay  
San Antonio, Pasig City  
1605 Philippines  
E [ups.philippines@deltaww.com](mailto:ups.philippines@deltaww.com)

### Australia

Delta Electronics (Australia) Pty Ltd.  
St Leonard's Corporate Centre  
Unit 18/39 Herbert Street, St Leonards NSW 2065, Australia  
T +61 2 9479 4200  
E [ups.australia@deltaww.com](mailto:ups.australia@deltaww.com)

### UK

Delta Electronics (UK) Ltd.  
Eltek House, Unit 1 Cleveland Road, Hemel Hempstead,  
Hertfordshire, HP2 7EY, UK  
T +44 1442 210805  
E [sales.gb@eltek.com](mailto:sales.gb@eltek.com)

### U.S.A

Delta Electronics (Americas) Ltd.  
46101 Fremont Blvd. Fremont, CA 94538  
T +1 510 668 5100  
E [ups.na@deltaww.com](mailto:ups.na@deltaww.com)

### Colombia

Delta Electronics Colombia SAS  
Cra 72 # 95 – 51 Bodega 16, Parque Empresarial Los  
Lagartos  
Bogota DC, Colombia  
T +57 317 4052794  
E [ups.colombia@deltaww.com](mailto:ups.colombia@deltaww.com)

### India

Delta Electronics India Pvt. Ltd.  
Plot No. 43, Sector-35, HSIIDC, Gurgaon-122001,  
Haryana, India  
T +91 124 4874 900  
E [ups.india@deltaww.com](mailto:ups.india@deltaww.com)

### Japan

Delta Electronics (Japan), Inc.  
2-1-14 Shibadaimon, Minato-Ku, Tokyo, 105-0012,  
Japan  
T +81-3-5733-1111  
E [jpstps@deltaww.com](mailto:jpstps@deltaww.com)

### Singapore

Delta Electronics Int'l (Singapore) Pte Ltd.  
17 Kallang Junction, #01-01, TRION,  
Singapore 339274  
T +65 6747 5155  
E [ups.singapore@deltaww.com](mailto:ups.singapore@deltaww.com)

### Vietnam

Delta Electronics (Vietnam) Co., Ltd.  
6th floor Gems Empire Tower, No. 201 Truong Chinh street,  
Phuong Liet Ward, Ha Noi City, Vietnam  
T +84 974 766 198  
E [ups.vietnam@deltaww.com](mailto:ups.vietnam@deltaww.com)

### Indonesia

Delta Electronics International (S) Pte Ltd.  
Soho Capital, 30th Fl, Unit SC3009  
Jl. Letjend S. Parman kav 28. Jakarta 11470 Indonesia  
T + 65 9667 4687  
E [ups.indonesia@deltaww.com](mailto:ups.indonesia@deltaww.com)

